



Part 9 (92)

WINCH

C3-series

SERVICE MANUAL

CONTENTS

Data	1
Tools	1
Construction and Function	2
Service Procedures	4
Adjusting the winch pulling power	4
Replacing the cable	4
Replacing controls for power take-off and winch	6
Replacing O-rings on the operating handles	6
Adjusting the control mechanism	6
Replacing seal on input shaft	7
Replacing washer springs in rear cover	8
Replacing discs on input shaft	9
Removing the winch	10
Installing the winch	11
Overhauling the winch	12
Disassembling the winch	12
Assembling the winch	17
Illustrations A.	19
B.	21
C.	23

Data

Make	Sepson
Reduction ratios:	
Worm gear	21.5:1
Planetary gear	3:1
Pulling power:	
At first bearing cable on drum	30,000 N (3,000 kp = 6,600 lbf)
At full number of cable turns on drum	22,000 N (2,000 kp = 4,840 lbf)
Oil capacities:	
Worm gear	1.2 litres (2.1 Imp. pints)
Planetary gear	0.6 litre (1.0 Imp. pint)
Oil type	API-GL-5 or MIL-L-2105B
Viscosity	SAE 90 or SAE 80/90
Cables	
Type	171 wires
Designation	8x17 (11/5/1) +5 +7 (6/1) +1 right-hand crossed
Diameter	12 mm (0.47")
Total length	40 metres (131 ft.)
Length of marking (red-marked)	9 metres (30 ft.) from final end

Tools

The following special tools are required for work on the winch

1647 Sleeve	2550 ²⁵⁰⁰ Sleeve	6104 Drift
1801 Standard handle	(2628) Lifting tool → 6239	6109 Plate
2001 Drift (2061)	2806 Drift	6110 Sleeve
2022 Sleeve	2819 Ring	6111 Sleeve
2132 Drift	2911 Drift	6117 Sleeve
2261 Extractor	4030 Extractor	6143 Extractor
2267 Drift	4113 Drift	6144 Sleeve
2337 Drift	6013 Press tool	

Unik Vmsk

Construction and Function

The winch, see Fig. 92-1 and Illustrations A, B and C, consists of a gear housing and a cable drum.

The winch is fixed to the vehicle by means of a bracket, see Fig. 92-2, and is driven by a power take-off, see Fig. 92-3, mounted on the power distribution box. In order to use up as little power as possible for driving the winch, it is fitted with two gears, a worm gear with reduction 21.5:1 and a planetary gear in the cable drum with reduction 3:1. The pulling power of the winch when the first bearing cable covers the cable drum is max. 30,000 N (3,000 kp = 6,600 lbf). Discs, see Fig. 92-4, have been fitted between the input shaft and the worm gear in order to prevent the winch from being overloaded. Dished springs have been placed between the worm gear and the rear cover, see Fig. 92-5, in order to be able to

adjust the pressure on the discs. A claw-type clutch, the moving part of which is the sun gear of the planetary assembly has been fitted for the purpose of permitting the cable drum to be disengaged when the cable has to be pulled out by hand since the power is transferred from the output shaft to the cable drum via the clutch. The gear is moved axially by a pull rod which is fixed to the gear and connected to an operating unit on the cover of the gear housing, see Fig. 92-6.

The cable drum is fitted with a cable brake, see Fig. 92-7, which prevents the drum from rotating by itself when the cable is pulled out.

The winch is disengaged and engaged and the power take-off operated by means of controls located behind the passenger seat, see Fig. 92-8.

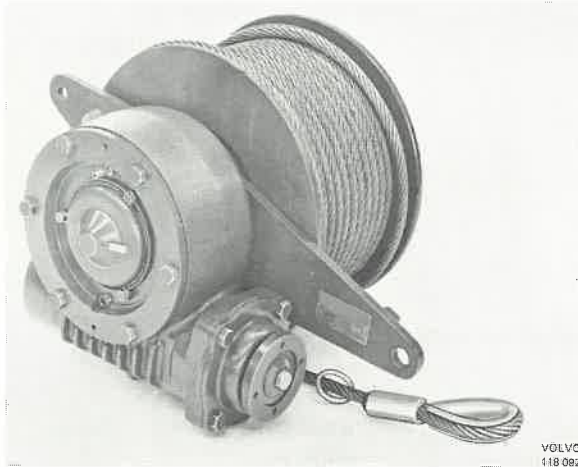

Fig. 92-1. Winch

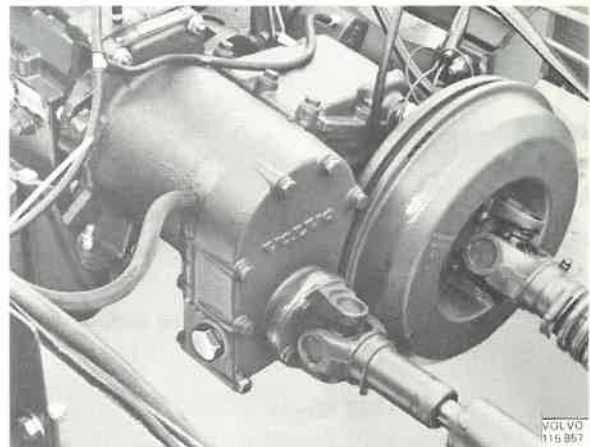

Fig. 92-3. Power take-off

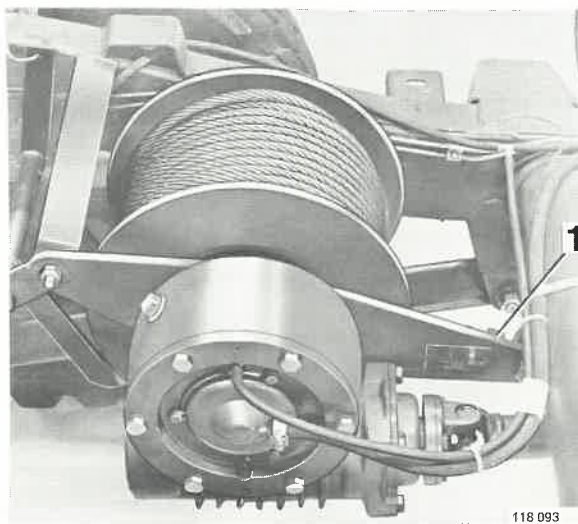

Fig. 92-2. Winch in vehicle

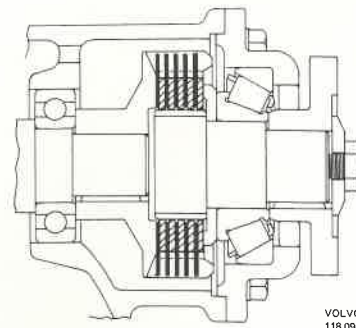
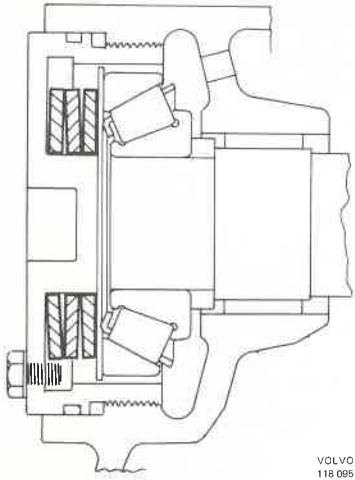
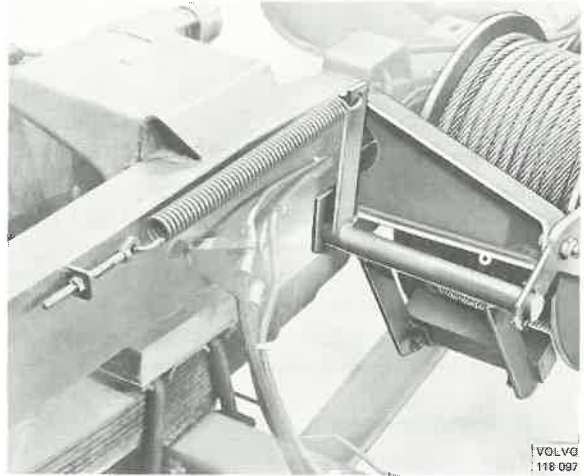

Fig. 92-4. Discs on input shaft



VOLVO
118 095

Fig. 92-5. Dished springs in rear cover



VOLVO
118 097

Fig. 92-7. Cable brake

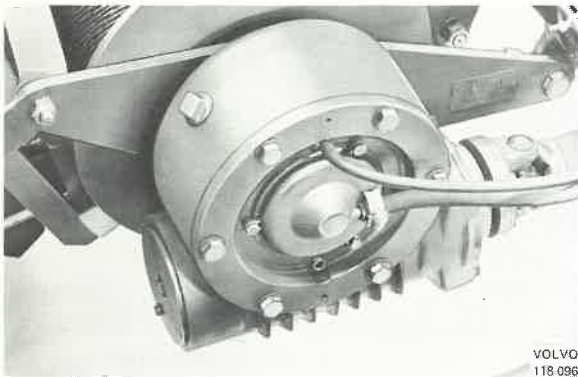

VOLVO
118 096

Fig. 92-6. Operating mechanism

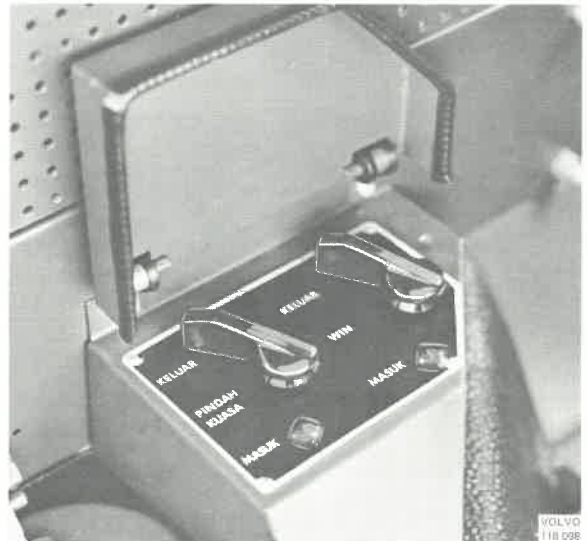

VOLVO
118 098

Fig. 92-8. Control switches for operating winch and power take-off

Service Procedures

Adjusting the pulling power of the winch

The maximum pulling power of the winch has been approved at 30,000 N (3,000 kp = 6,600 lbf.) when the first bearing cable covers the cable drum. If the winch pulling power deviates from this figure when test-pulling with a dynamometer, this can be remedied by adjusting the pressure on the discs between the worm gear and the input shaft, see below.

Too little pulling power

1. Turn clockwise the rear cover on the gear housing, see Fig. 92-9.

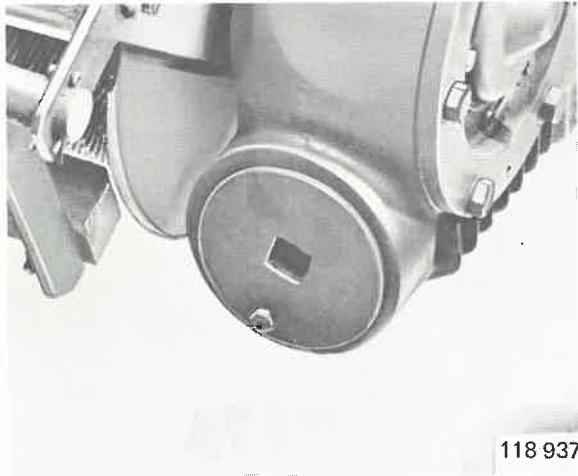

Fig. 92-9. Gear housing

2. Each 1/6 turn on the cover corresponds to increasing the pulling power by 2650 N (265 kp = 585 lbf.).
3. If the increase is less, this may be a sign that the discs on the input shaft are worn and have to be replaced. If so, see under "Replacing the discs on the input shaft".

Excessive pulling power

1. Turn anti-clockwise the rear cover on the gear housing.
2. When the cover has been turned 1/6 turn, the pulling power should be reduced by 2650 N (265 kp = 585 lbf.).
3. If the reduction is less, this may be a sign that the discs on the input shaft are jamming.

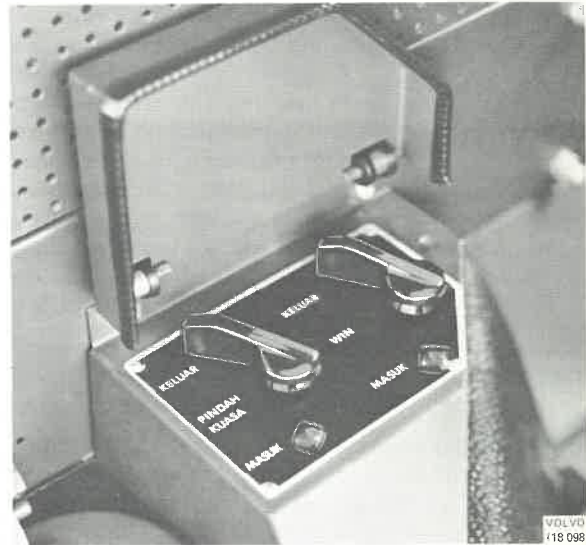

Fig. 92-10. Control panel

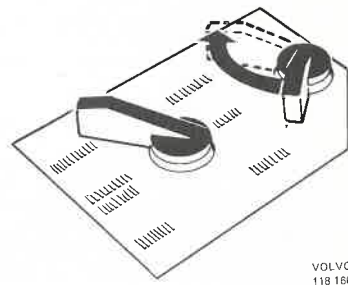

Fig. 92-11. Disengaging the winch

Replacing the cable

Removing

1. Disengage the winch by turning back the right-hand control switch, see Fig. 92-00, behind the passenger seat, see Fig. 92-00.
2. Pull out the cable.
3. Remove the bolt, Fig. 92-12, securing the cable and release the cable from the drum.

Checking and replacing the parts

Check to make sure that the fair-lead ring and the leading (1) and trailing (2) Fig. 92-12 fair leads are free from damage. Replace damaged material. Grease the rolls for the fair leads and check that the rolls rotate easily.

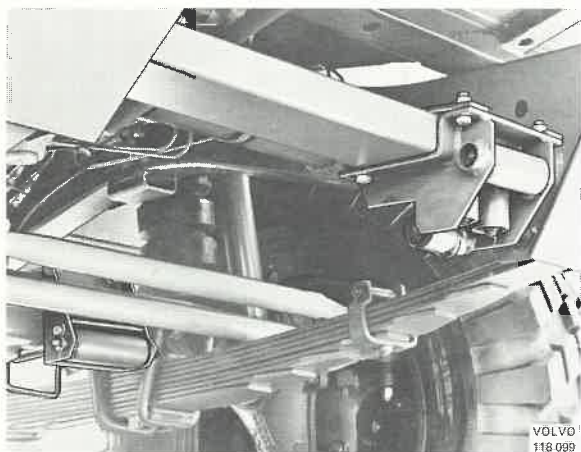

Fig. 92-12. Fair lead

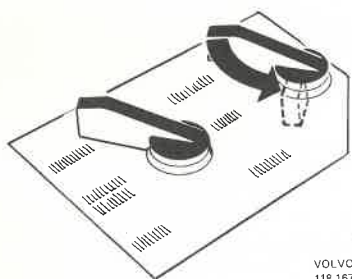

Fig. 92-13. Switching on the winch

Installing

1. Fit the new cable through the fair leads and put on the spring at the bracket. Clamp together the spring ends.
2. Insert the cable through the hole on the drum and secure with the bolt.
3. Start the engine. Engage the winch by turning the control switch forwards, see Fig. 92-14.
4. Engage the power take-off by turning the control switch forwards, see Fig. 92-24.

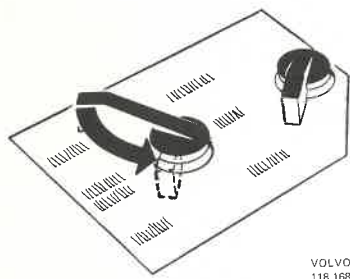

Fig. 92-15. Distribution gear in neutral

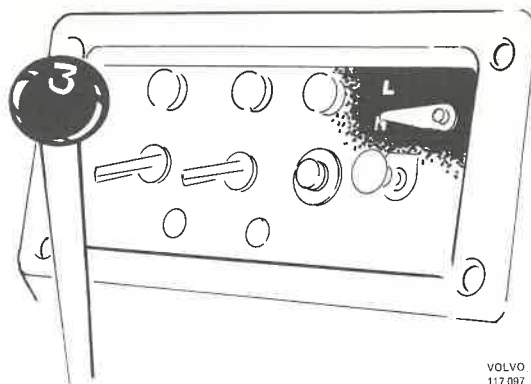

Fig. 92-14. Switching on the power take-off

5. Put the distribution gear in neutral. Note that the arrow on the instrument panel, see Fig. 92-15, is in position N.
6. Engage reverse and release the clutch. Throttle slowly and carefully. Wind in the cable. Keep the cable stretched while rolling it up and make sure that it winds neatly on the drum. Grease the cable.
7. Depress the clutch pedal and break-off the rolling-up when the cable eyelet can be fixed in the lifting hook on the bumper and the cable is so slack that front axle movement is not hindered in any way.
8. Switch off the engine and disengage the power take-off.
9. Adjust the cable drum brake, see Fig. 92-16, with the adjusting nut so that the distance A is 320 mm (12.5 in.), see Fig. 92-17.

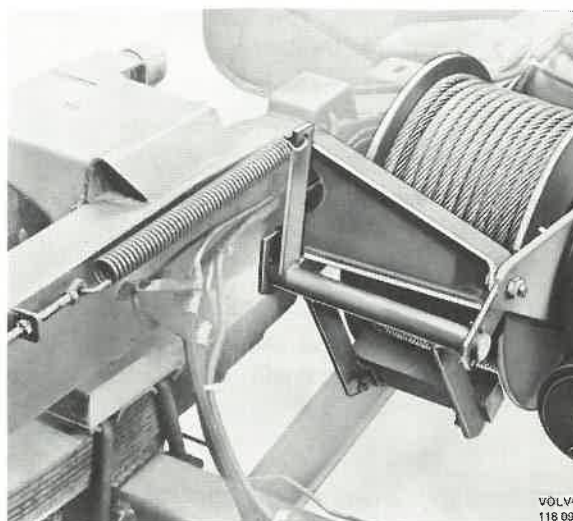
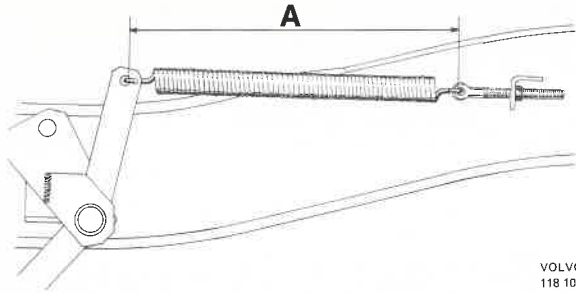
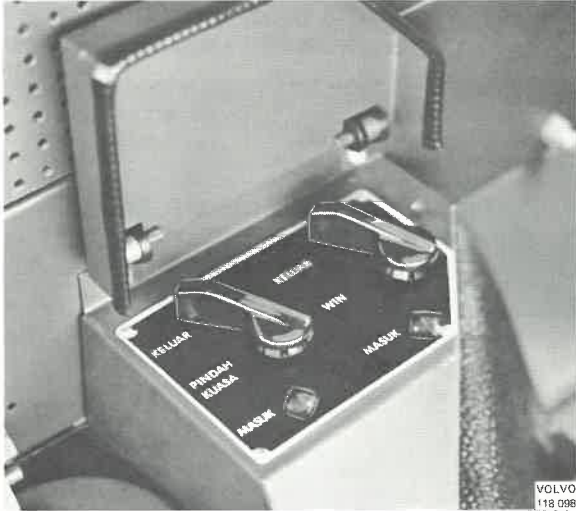

Fig. 92-16. Cable drum brake



VOLVO
118 100

Fig. 92-17. Check measurement for spring



VOLVO
118 098

Fig. 92-18. Control panel

Replacing the control switches for the power take-off and winch

1. Place a suitable tool under the control switch and pull it out of its housing.
2. Remove the bolts securing the casing, see Fig. 92-18, on which the controls sit.
3. Remove the lock ring securing the control switch housing to the casing.
4. Disconnect the hoses from the housing.
5. Remove the control switch from the new control.
6. Place a new O-ring on the housing. Secure the housing to the casing. Fit the lock ring.
7. Connect the hoses and fit the casing.
8. Press the control switch into the housing.
9. Start the engine and check that the unit concerned can be engaged and disengaged.

Replacing the O-ring on the control switches

1. Place a suitable tool under the switch and pull the switch out of the housing.

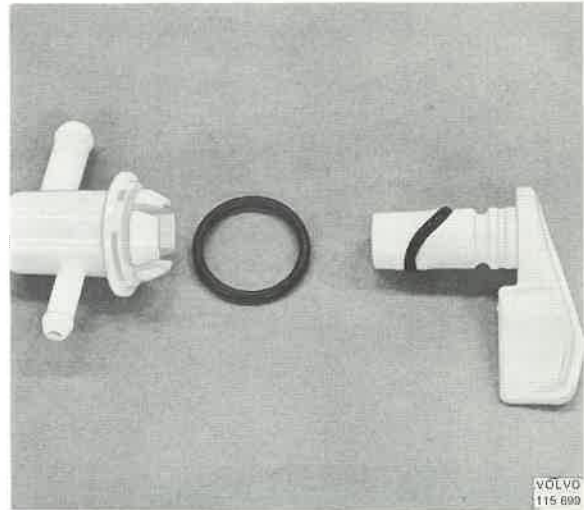

VOLVO
115 800

Fig. 92-19. Control switch and valve

2. Replace the O-ring, see Fig. 92-19, on the switch and grease it.
3. Press the control switch into the housing.
4. Start the engine and check that the unit concerned can be engaged and disengaged.

Adjusting the control mechanism

1. Remove the cover for the pressure box, see Fig. 92-20. Remove the thrust spring.

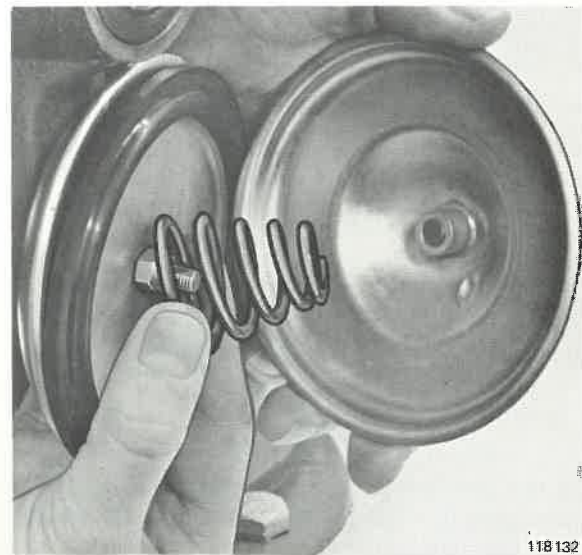

118 132

Fig. 92-20. Removing cover and spring.

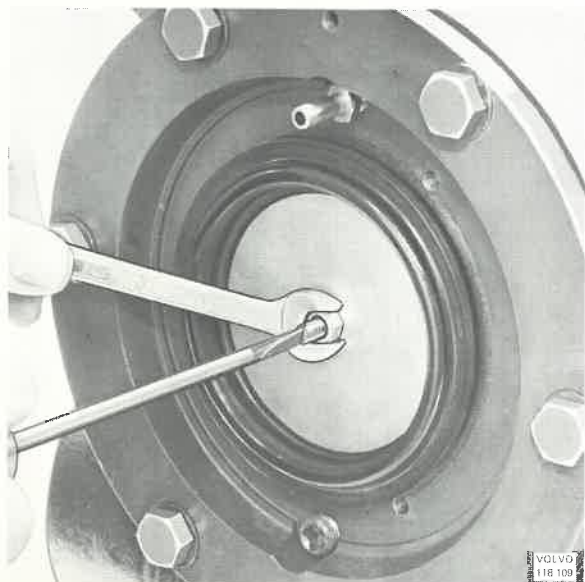

Fig. 92-21. Removing the nut

2. Remove the nut on the thrust rod see Fig. 92-21.
- 2 Turn the flange on the gear housing input shaft. Push in the pull rod so that the cable drum cannot rotate.
- 3 Turn the flange while pulling the rod out at the same time. Discontinue the turning when the teeth on the sun gear are opposite the teeth on the output shaft gear.
- 4 Screw the thrust washer on the rod. The washer should be placed so that there is a clearance of 1–1.5 mm (0.04–0.06”) between the washer and the gear housing cover. See Fig. 92-22.

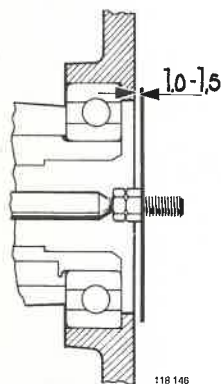

Fig. 92-22. Adjusting the clearance

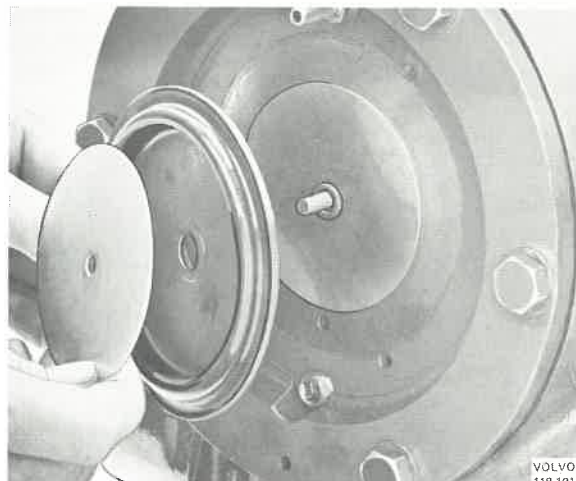

Fig. 92-23. Fitting the diaphragm

4. Place the spacer washer on the rod. Fit the diaphragm and the thrust washer, see Fig. 92-23. Tighten up the nut.
5. Fit the thrust washer in position. Fit the cover and tighten up.

Replacing the seal on the input shaft

1. Drain the oil from the winch gear housing by removing the drain plug (3), see Fig. 92-24.
2. Disconnect the propeller shaft, see Fig. 92-25, from the winch flange.

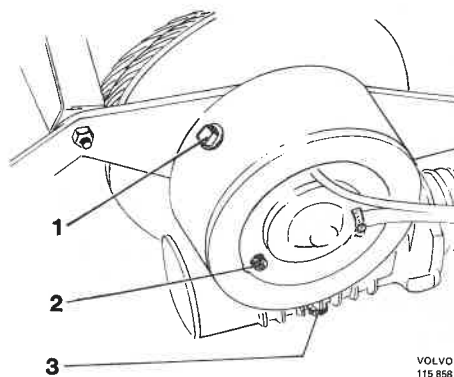

Fig. 92-24. Worm gear plugs

1. Filler plug
2. Level plug
3. Drain plug

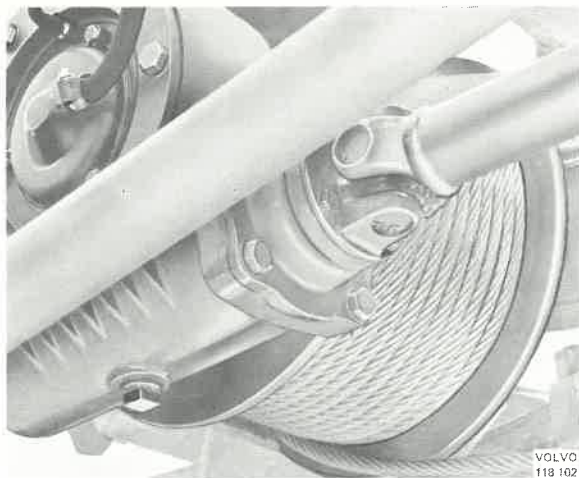

Fig. 92-25. Removing the propeller shaft

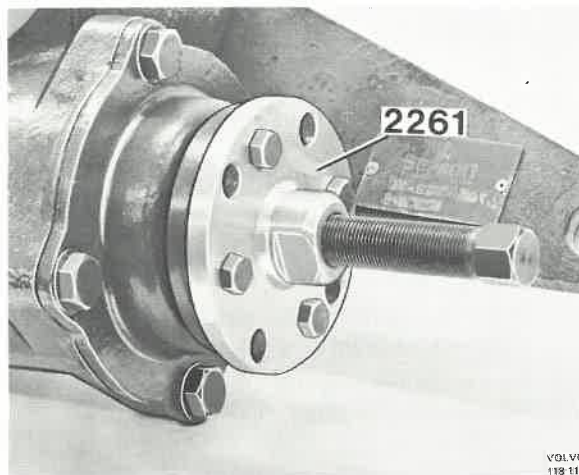

Fig. 92-26. Removing the flange

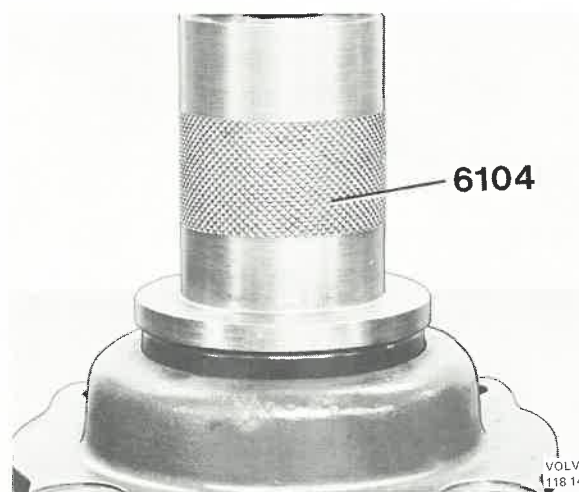

Fig. 92-27. Pressing in the seal

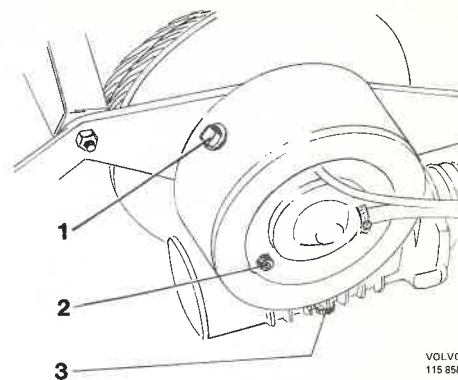

Fig. 92-28. Worm gear plugs

3. Remove the bolt securing the flange. Pull off the flange with 2261, see Fig. 92-26.
4. Pull out the seal with 4030.
5. Grease the sealing lips on the seal. Drive the seal into the cover with 6104, see Fig. 92-27.
6. Fit the flange in position. Use the washer for the bolt and an M10 bolt with 30 mm (1.2 in.) thread length and pull in the flange.
7. Remove the bolt and fit the proper one.
8. Connect up the propeller shaft. Tighten the bolts to a torque of 23-30 Nm (2.3-3.0 kpm = 17-22 lbftf).
9. Fit the drain plug and remove the level plug (2) and the filler plug (1), see Fig. 92-28. Fill with oil. Concerning quantity and quality, see under "Data".

Replacing the washer springs in the rear cover

1. Drain the oil from the winch gear housing by removing the drain plug (3), see Fig. 92-28.

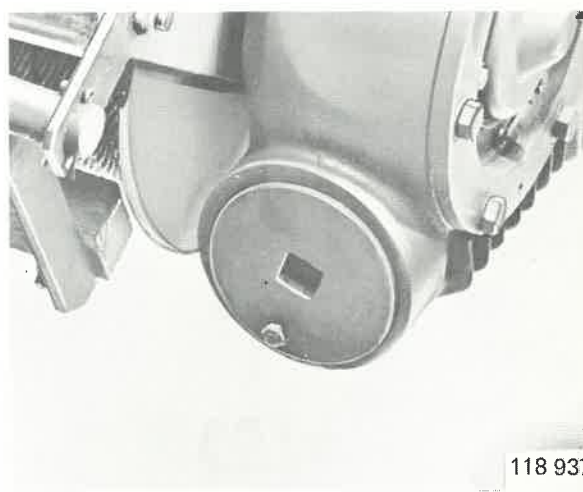

Fig. 92-29. Gear housing

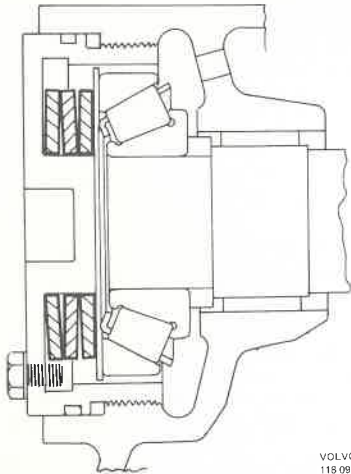

Fig. 92-30. Location for washer

2. Clean round the rear cover, see Fig. 92-29, and screw it out. When the cover is being removed, the washer springs and a spacer ring as well as an outer ring for the worm roller bearing will also accompany it.
3. Replace the O-ring on the cover. Place the new washers in the cover, noting their interlocation, see Fig. 92-30.
4. Place the outer ring and spacer washer in position in the housing.
5. Screw in the cover.
6. Remove the bolt in the cover. Screw in the cover so far that a measurement, $A = 20.1 \text{ mm}$ (0.8 in.), see Fig. 92-31, can be measured through the hole of the cover. Screw in the bolt when the correct measurement has been obtained.

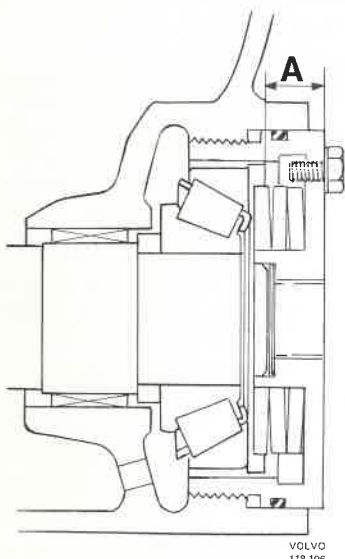

Fig. 92-31. Adjusting the pre-load

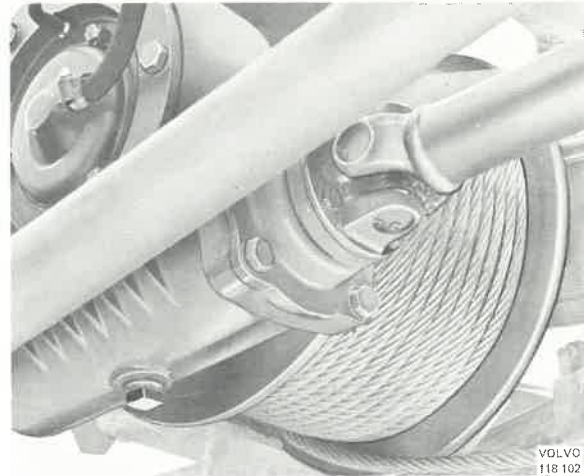

Fig. 92-32. Removing the propeller shaft

7. Fit the drain plug and remove the level plug (2) and the filler plug (1). Fill with oil. Concerning quantity and quality, see under "Data".

Replacing the discs on the input shaft

1. Drain the oil from the winch gear housing by removing the drain plug (3), see Fig. 92-28.
2. Disconnect the propeller shaft, see Fig. 92-32, from the winch flange.
3. Remove the bolts securing the cover to the input shaft. Take out the shaft and cover.
4. Remove the discs from the shaft. Clean the cover and the housing.
5. Oil the new discs, see Fig. 92-33. Place them on the shaft starting with the one with internal teeth

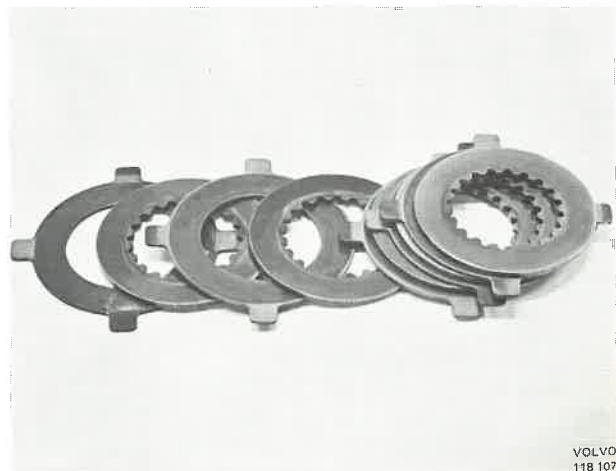

Fig. 92-33. Discs

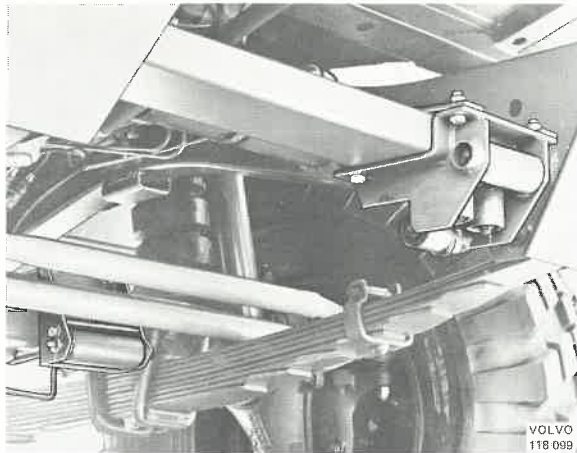

Fig. 92-34. Fair lead

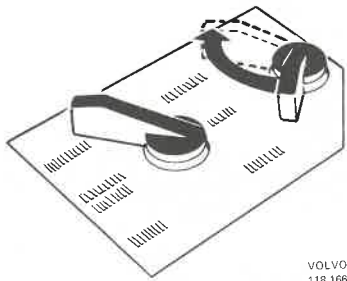

Fig. 92-35. Disengaging the winch

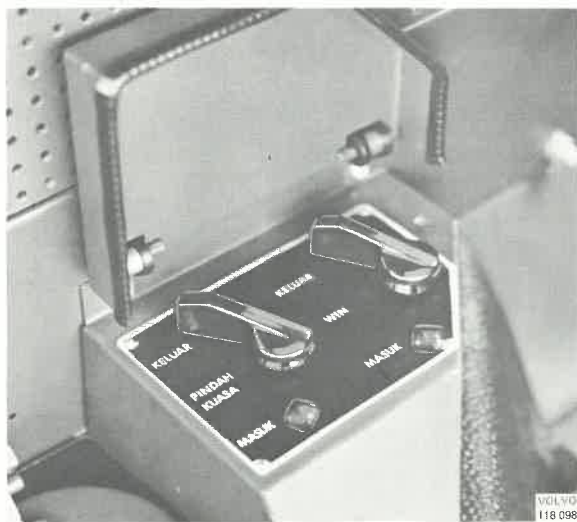

Fig. 92-36. Control panel

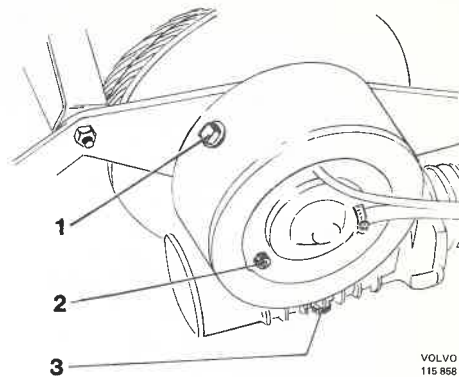

Fig. 92-37. Worm gear plugs

1. Filler plug
2. Level plug
3. Drain plug

and thereafter alternating with discs with external and internal teeth.

6. Fit a new gasket on the cover.
7. Place the input shaft in position and tighten up the bolts.
8. Connect up the propeller shaft. Tighten the bolts to a torque of 23-30 Nm (2.3-3.0 kpm = 17-22 lbfft).
9. Fit the drain plug and remove the level plug (2) and the filler plug (1). Fill with oil. Concerning quantity and quality, see under "Data".

Removing the winch

1. Pull the cable through the leading fair lead, see Fig. 92-34. Disconnect the fair lead ring from the spring at the gearbox attachment.
2. Disengage the winch by turning back the right-hand switch, see Fig. 92-35 behind the passenger seat, see Fig. 92-36.
3. Turn the propeller shaft for the winch so that the cable winds up on the cable drum.
4. Secure the cable to the drum.
5. Drain the oil from the winch gear housing by removing the drain plug (3), see Fig. 92-37.
6. Drain the oil from the cable drum planetary gear by removing the plug in the cable drum, and by turning the drum so that the plug is at the bottom.
7. Disconnect the propeller shaft from the winch flange.
8. Remove the ventilation hose and the hose to the control unit, see Fig. 92-38.
9. Remove the spring for the cable drum brake.
10. Hold up the winch with the help of a jack or similar against the gear housing.

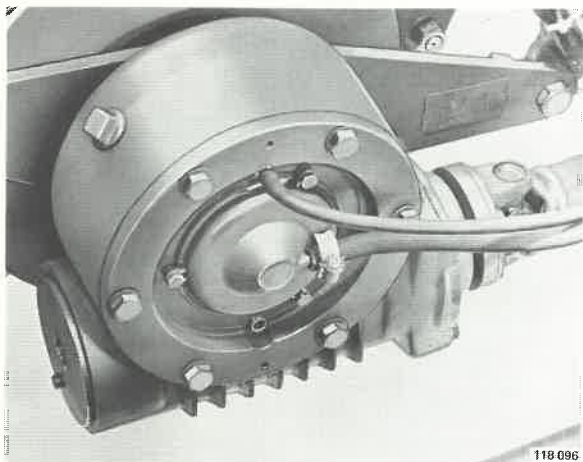

Fig. 92-38. Ventilation hose

11. Release the tensioning bolt (1) at the leading attachment, see Fig. 92-39.
12. Remove the bolt for the rear suspension.
Remove the bracket for the cable drum brake.
13. Remove the bolt for the front suspension and lift off the winch.

Installing the winch

1. Place the winch in position.
2. Fit the leading suspension bolt.
3. Place the bracket for the cable drum brake in position and fit the trailing bolt.

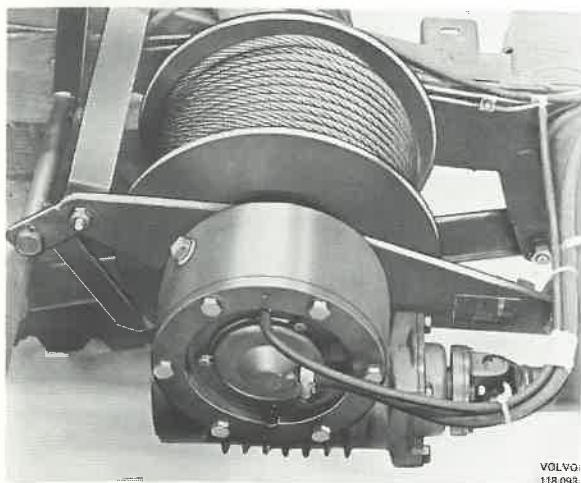

Fig. 92-39. Winch in vehicle

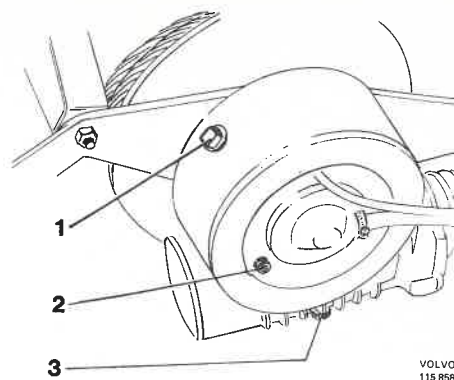

Fig. 92-40. Worm gear plugs

4. Screw in the tensioning bolt at the leading attachment so that it is against the attachment in the frame. Lock the bolt.
5. Remove the jack, etc.
6. Fit the spring for the cable drum brake in position.
7. Fit the ventilation hose and the hose to the control unit.
8. Connect up the propeller shaft. Tighten the bolts to a torque of 23-30 Nm (2.3-3.0 kmp = 17-22 lbfft).
9. Remove the level plug (2), see Fig. 92-40, on the gear housing cover. Remove the filler plug (1) and fill with oil. Concerning quantity and quality, see under "Data".
10. Remove the plug in the cable drum cover. Turn the input shaft so that the plug on the cable drum is 122 mm (4.8 in.) above the lower edge of the drum, see Fig. 92-41. Fill with oil. Concerning quantity and quality, see under "Data". On vehicles with a straight frame, it may be difficult to fill with oil, in which case a funnel and a hose must be used for this purpose.

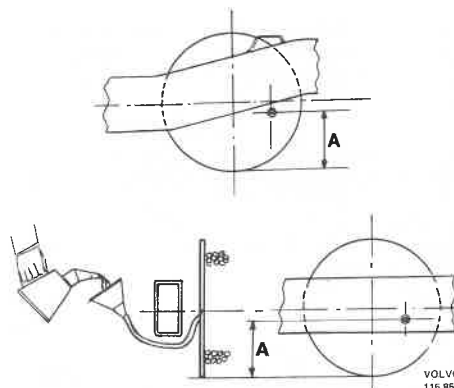
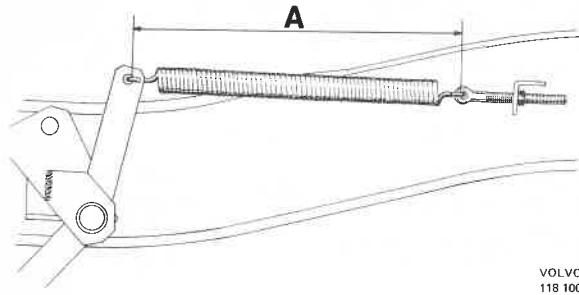
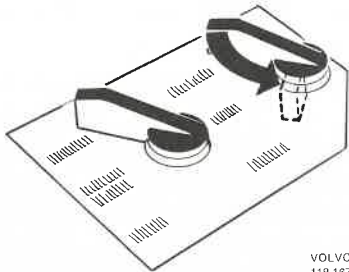

Fig. 92-41. Topping-up with oil



VOLVO
118 100

Fig. 92-42. Check-measurement for spring



VOLVO
118 187

Fig. 92-43. Engaging the winch

11. Disconnect the cable from the cable drum.
12. Pull out the cable and hang it up on the cable guide ring and pull it through at the trailing and leading cable guide. Secure the cable to the lifting hook on the bumper. Make sure that the cable is so slack that it does not hamper movement of the front axle.
13. Adjust the cable drum brake with the adjusting screw so that the distance A is 320 mm (12.5 in.), see Fig. 92-42.
14. Engage the winch by turning the right-hand control switch as shown in Fig. 92-43.

Overhauling the winch

Disassembling

1. Remove the cover for the pressure box. Remove the thrust spring.
2. Remove the nut on the thrust rod, see Fig. 92-44.

Remove the thrust washer and the diaphragm.

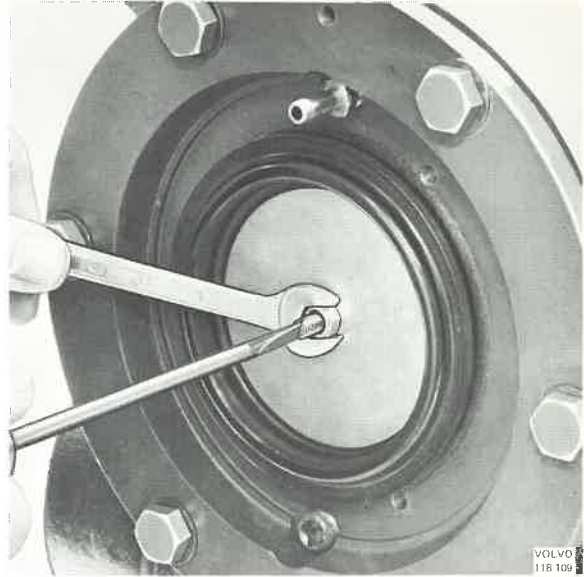

VOLVO
118 109

Fig. 92-44. Removing the nut

3. Remove the bolts securing the cover to the cable drum, see Fig. 92-45. Pull off the cover with the help of two bolts (M10 with 40 mm = 1.5 in. thread length).
4. Remove the Allen bolts (10mm = 0.4 in.) holding the cover for the planetary gears. Remove the bolts and the lock washers holding the shafts, see Fig. 92-46.



VOLVO
118 110

Fig. 92-45. Removing the cover

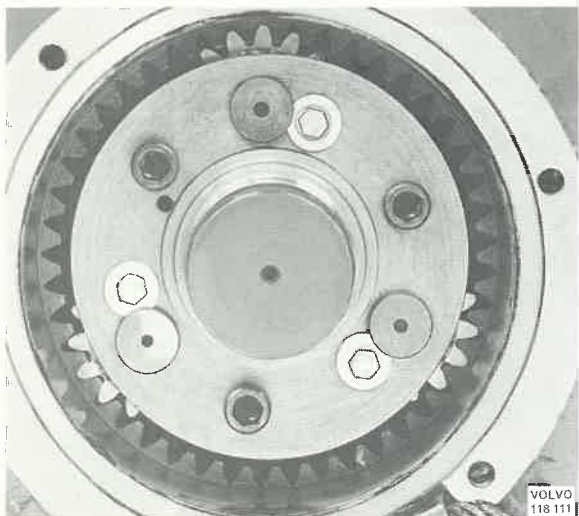

Fig. 92-46. Cover for the planetary gears

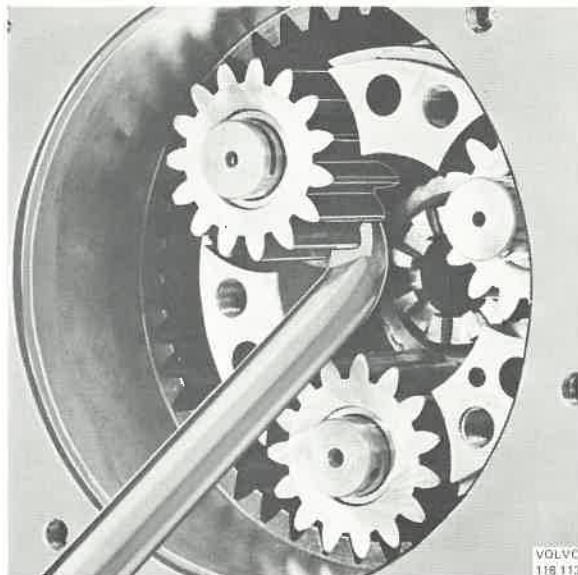

Fig. 92-48. Removing the gear

5. Pull off the cover with the help of three bolts (M6 with 30 mm = 1.2 in. thread length), see Fig. 92-47.
6. Remove the sun gear with the pull rod.
7. Place the winch on its high edge. Remove the washers on the planetary gears and lever out the gears with 2337, see Fig. 92-48. Remove the needle bearings and the washers on the shafts.
8. Remove the circlip securing the planetary gear cage to the shaft. Fit 6143, see Fig. 92-49, and pull off the cable drum and cage.
9. Remove 6143 and fit 2628 and lift out the unit, see Fig. 92-50.

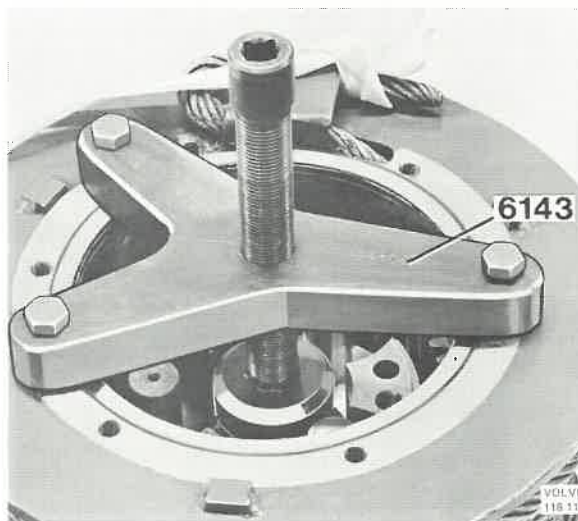

Fig. 92-49. Pulley of the cable drum

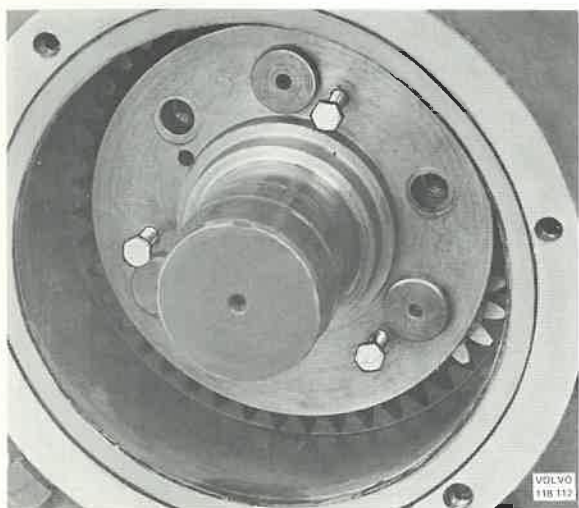

Fig. 92-47. Removing the cover

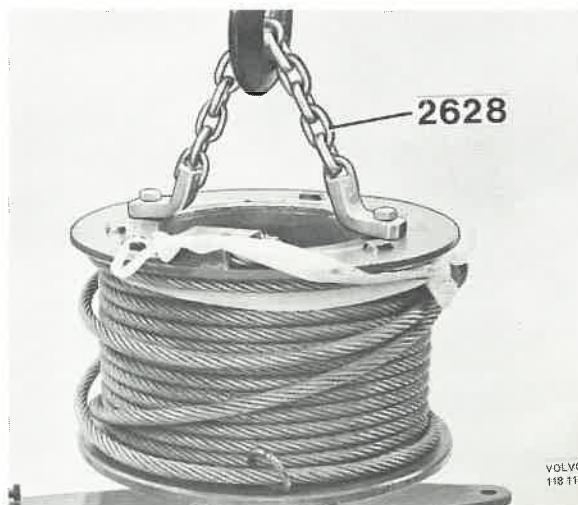

Fig. 92-50. Removing the drum

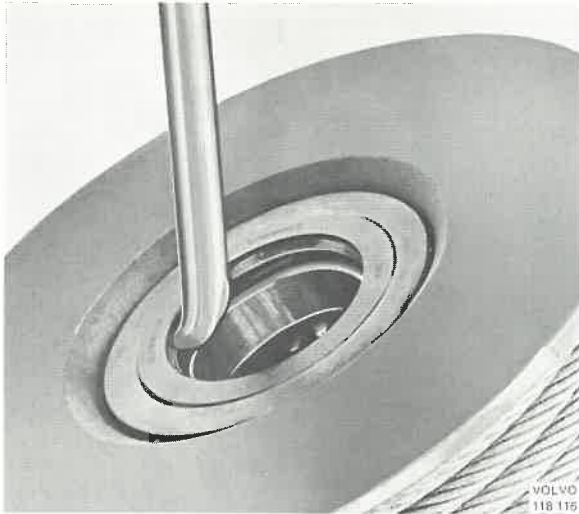

Fig. 92-51. Removing the seal

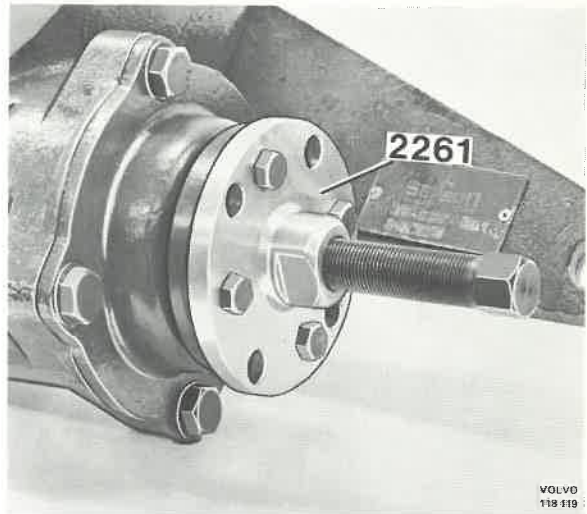

Fig. 92-54. Removing the flange

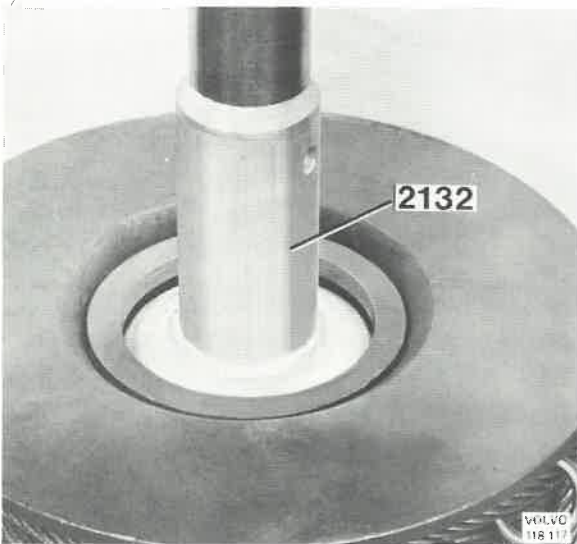

Fig. 92-52. Pressing out the bearing

10. Remove the planetary gear cage from the cable drum.
11. Remove the circlip securing the bearing in the drum.
12. Lever out the seal in the drum with 2337, see Fig. 92-51.
13. Place the drum in a press and press out the bearing with 2132, see Fig. 92-52.
14. Remove the bolts securing the cover to the worm gear housing. Mark up the location of the cover and pull it off with two bolts (M6 with 40 mm = 1.5 in. thread length), see Fig. 92-53.
15. Remove the bolt holding the flange in position. Pull off the flange with 2261, see Fig. 92-54.

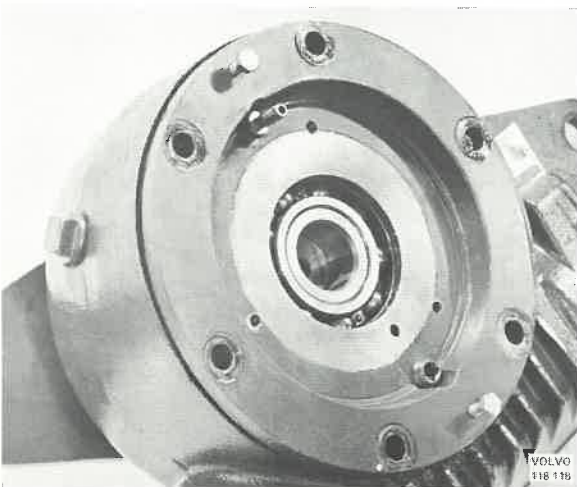

Fig. 92-53. Removing the cover

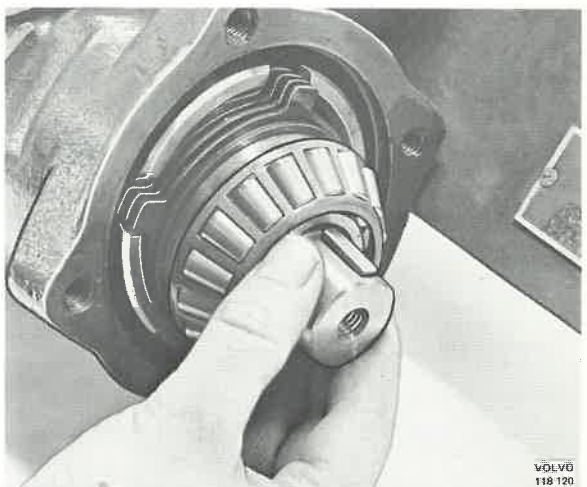

Fig. 92-55. Removing the input shaft

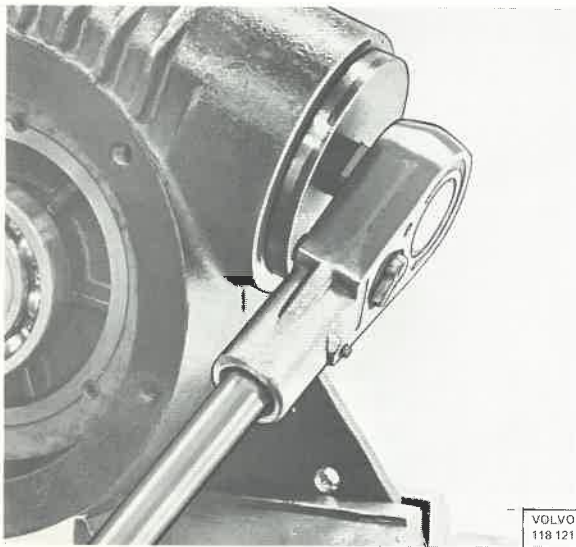

Fig. 92-56. Removing the cover

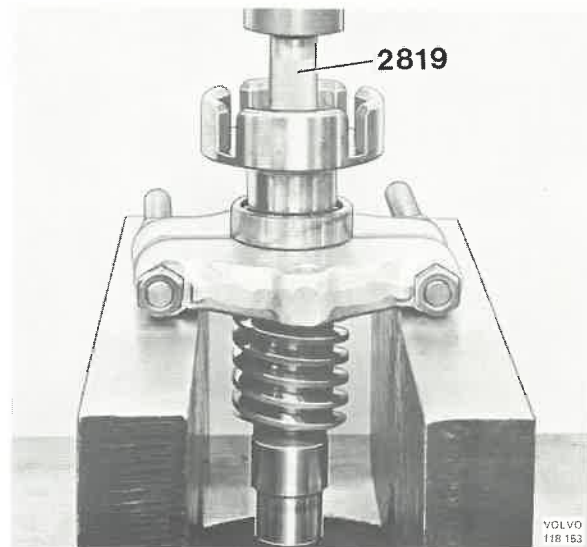

Fig. 92-58. Removing the bearing and flange

16. Remove the cover and take out the input shaft and discs, see Fig. 92-55.
17. Fix the gear housing in a vice. Screw out the rear cover, see Fig. 92-56. Remove the cover, the thrust washers, spacer ring and bearing race.
18. Remove the bolts securing the gear housing and the support shaft at the bracket. Remove the housing and shaft from the bracket.
19. Place the gear housing on 2911, see Fig. 92-57, and press out the worm with 2819. Lift off the housing.
20. Remove the spacer washer and press out the needle bearing with 4113.
21. Fit a bearing extractor under the bearing on the worm. Press off the bearing and flange with 2819, see Fig. 92-58.
22. Press the worm gear shaft out of the housing. See Fig. 92-59.

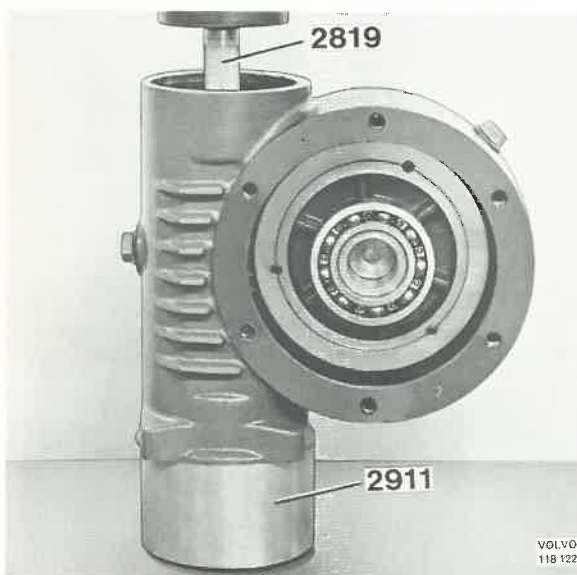

Fig. 92-57. Pressing out the worm

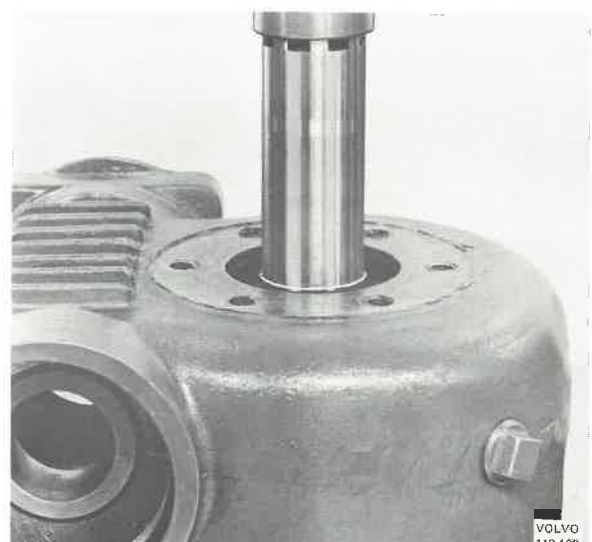

Fig. 92-59. Pressing out the worm gear

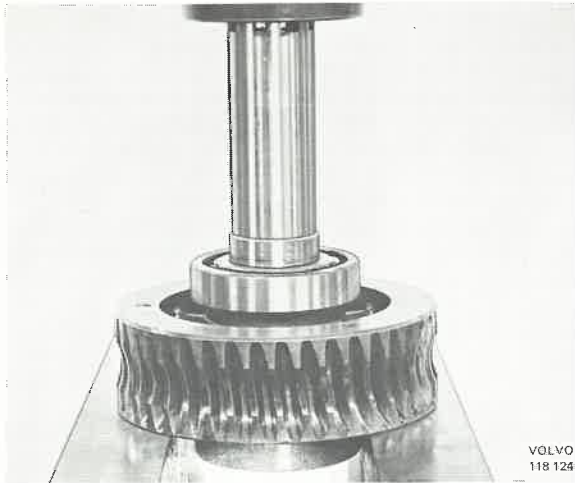

Fig. 92-60. Pressing out the shaft

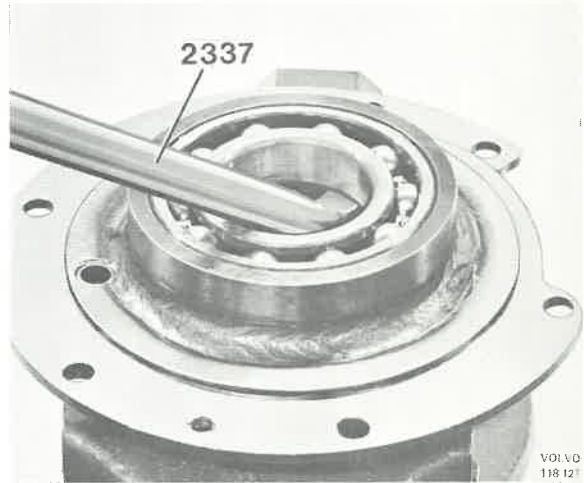

Fig. 92-63. Levering out the seal

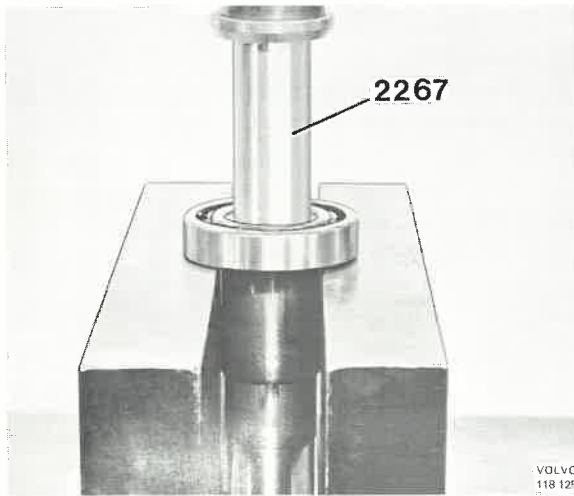

Fig. 92-61. Pressing off the bearing

23. Press the shaft out of the bearing and worm gear, see Fig. 92-60.
24. Press the bearing off the shaft with 2267, see Fig. 92-61.
25. Place the cover for the worm gear on 2911, see Fig. 92-62, and press out the bearing with 2022.
26. Lever the seal out of the cover for the cable drum with 2337, see Fig. 92-63.
27. Place the cover on 2911, see Fig. 92-64, and press out the bearing with 2001.
28. Place the cover for the input shaft on 2911, see Fig. 92-65, and press out the seal with 2267.
29. Invert the cover and press out the outer race with 6013 + 1801, see 92-66.

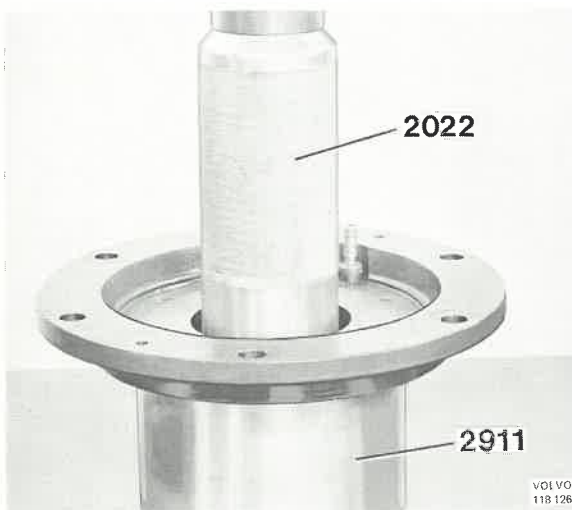

Fig. 92-62. Pressing out the bearing (worm gear)

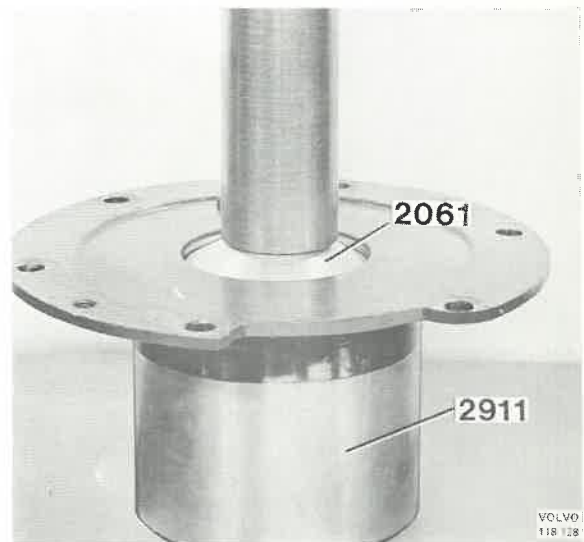

Fig. 92-64. Pressing out the bearing (drum)

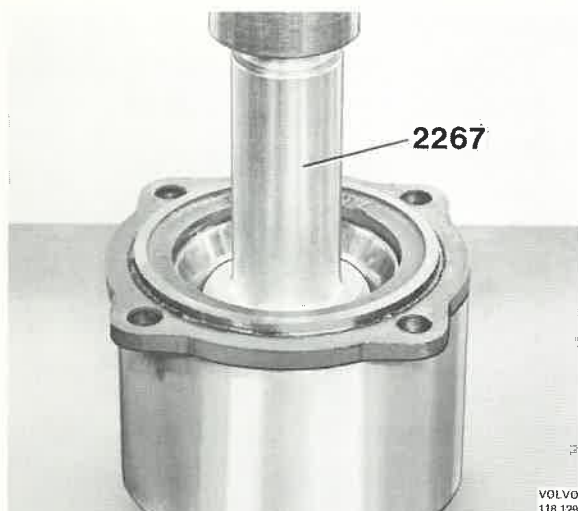

Fig. 92-65. Pressing out the seal



Fig. 92-67. Pressing off the bearing (input shaft)

30. Remove the discs and the key from the input shaft. Place the shaft in 2022, see Fig. 92-67, and press the bearing off the shaft.

Checking and replacing the parts

Clean all parts and check them for damage and wear. All damaged or worn parts as well as sealing rings must be replaced. When replacing a sealing ring, check carefully those surfaces against which the rings seal.

Assembling

1. Press the needle bearing for the worm into the housing with 6144 + 1801, see Fig. 92-68.
2. Place the housing on 2911 and press in the ball bearing with 2806, see Fig. 92-69.

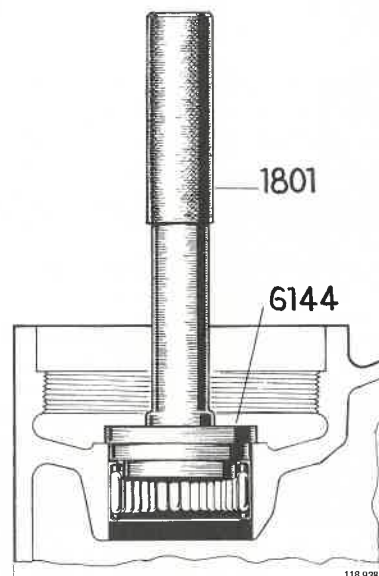

Fig. 92-68. Pressing in the needle bearing

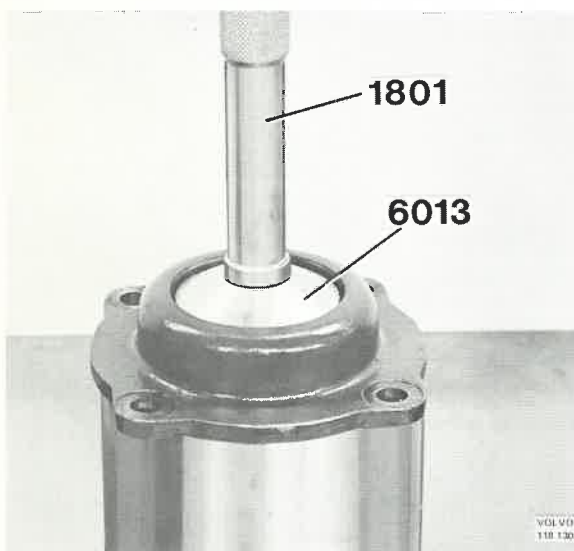

Fig. 92-66. Pressing out the outer race

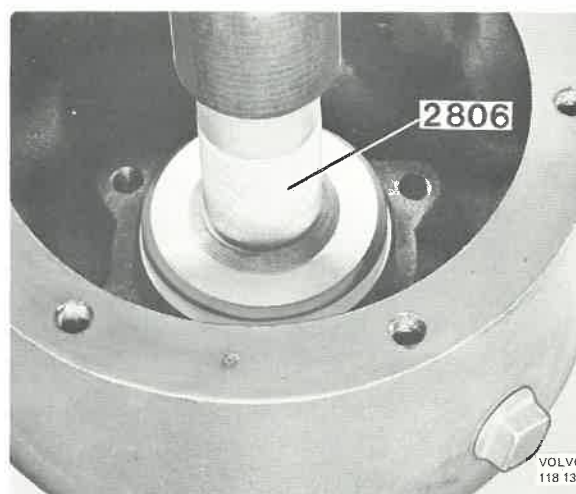

Fig. 92-69. Pressing in the ball bearing



Fig. 92-70. Pressing on the bearing

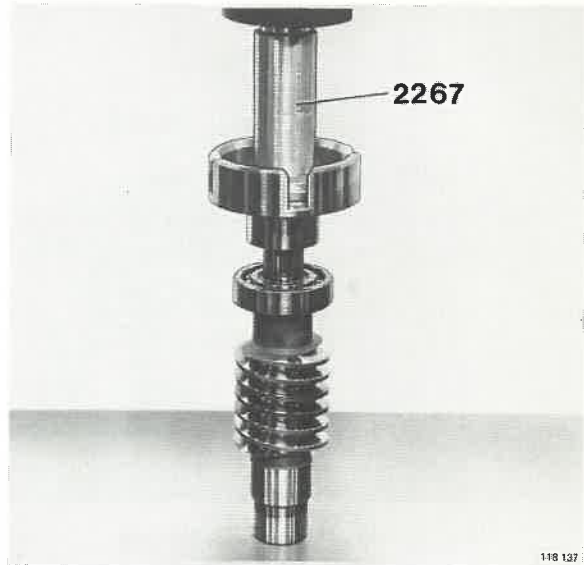

Fig. 92-73. Pressing on the bearing and flange

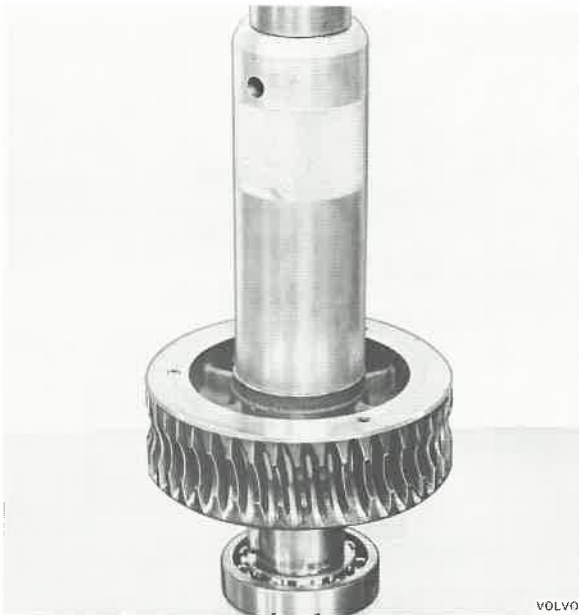

Fig. 92-71. Pressing on the worm gear

3. Press the bearing on the shaft for the worm gear, see Fig. 92-70.
4. Press the worm gear on the shaft with 1647, see Fig. 92-71.
5. Place the housing on 2022, see Fig. 92-72, and press the worm gear into the housing.
6. Press the bearing and the flange on the worm with 2267, see Fig. 92-73.
7. Press the worm into the housing with 2267. See Fig. 92-74.
8. Place 6111 in plate 6109. Place the housing so that the worm flange rests against the tool.
9. Place the spacer washer on the worm. Note that the bevelled inner edge of the washer should face to the front, see Fig. 92-75.



Fig. 92-72. Pressing in the worm gear



Fig. 92-74. Pressing in the worm

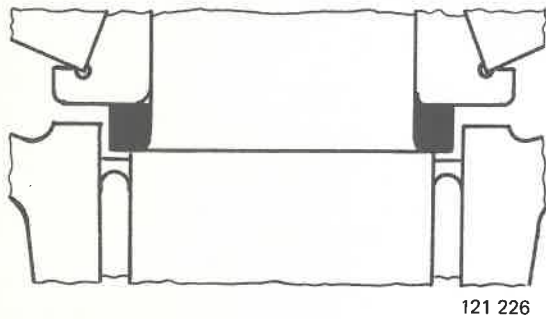

Fig. 92-75. Location for the washer

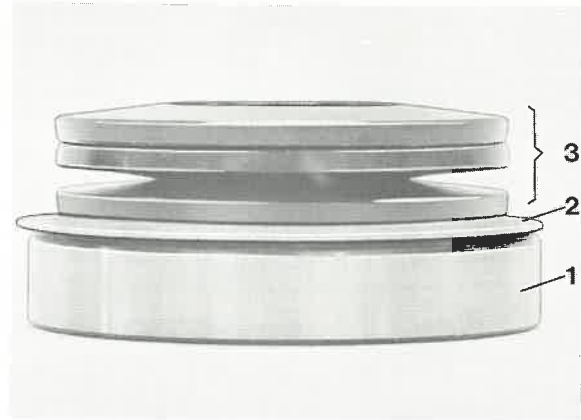

Fig. 92-77. Location for the washer

10. Press the roller bearing outer race onto the shaft with 6110, see Fig. 92-76.
11. Place the bearing outer ring (1), spacer ring (2) and the thrust washers (3) on the shaft. Note the location of the washers, see Fig. 92-77.
12. Fit a new O-ring on the rear cover. Screw the cover into the housing until the cover projects about 6 mm (0.24") outside the housing.
13. Place the washer on the input shaft. Note that the bevel should face upwards. Press on the roller bearing with 6110 see Fig. 92-78. Place the key on the shaft.
14. Oil the discs. Place them on the shaft starting with one with internal teeth and thereafter alternately with external and internal teeth.
15. Press the outer race into the front cover with 2001, see Fig. 92-79.

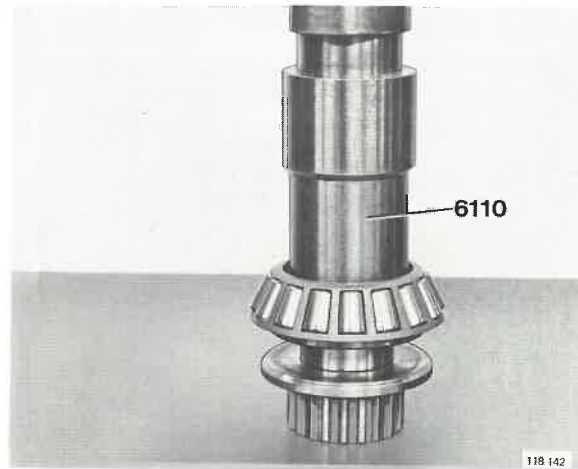

Fig. 92-78. Pressing on the bearing

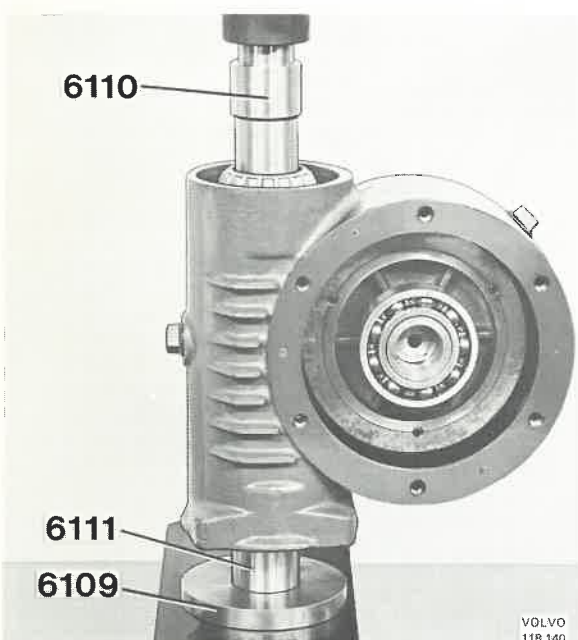

Fig. 92-76. Pressing on the outer race



Fig. 92-79. Pressing in the outer race

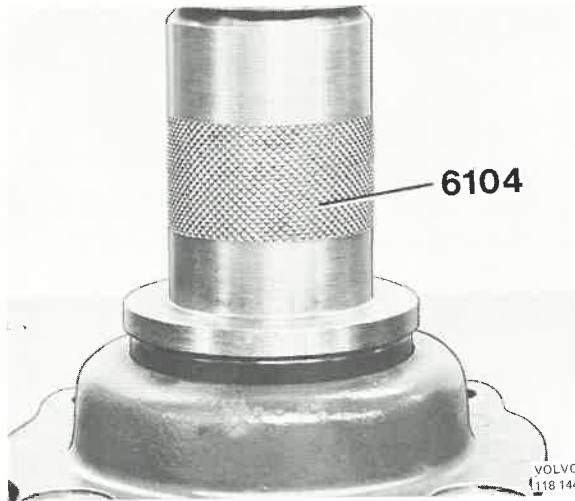

Fig. 92-80. Pressing in the seal

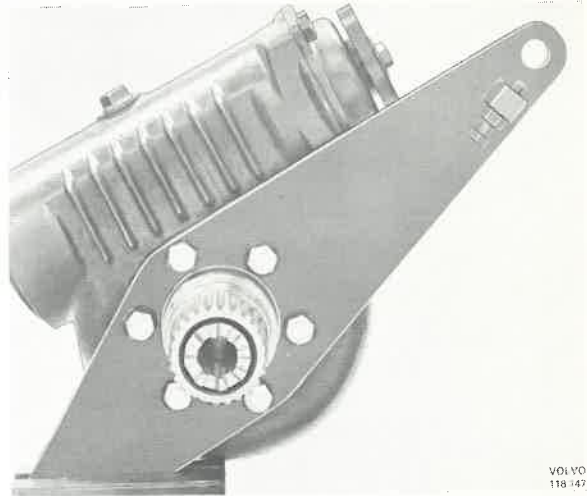

Fig. 92-83. Fitting the housing

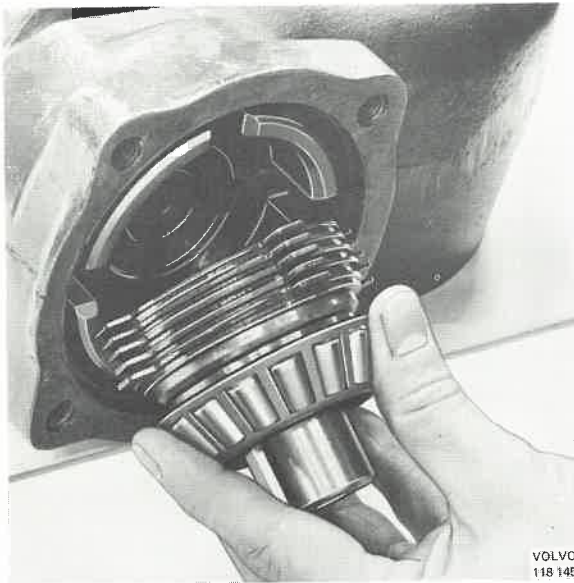

Fig. 92-81. Fitting the input shaft

16. Press the seal into the cover with 6104, see Fig. 92-80. Grease the lips on the seal.
17. Incline the gear housing and fit the input shaft in the housing, see Fig. 92-81.
18. Coat the cover contact surface against the housing with sealing agent. Fit the cover in position and tighten up.
19. Place the flange on the input shaft. Tighten it with a bolt (M10 with 30 mm = 1.2 in. thread length). Remove the bolt and fit the proper one.
20. Press the seal into the support shaft with 6104, see Fig. 92-82. The seal must face as shown in the Fig.

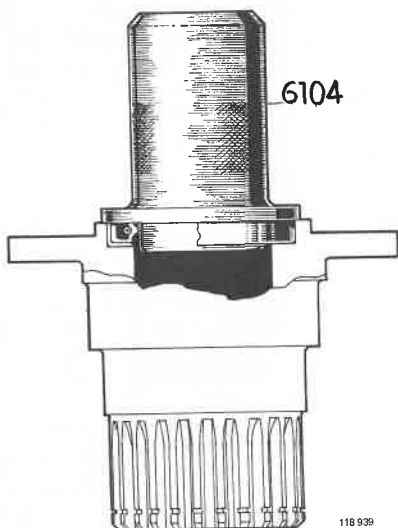

Fig. 92-82. Pressing in the support shaft

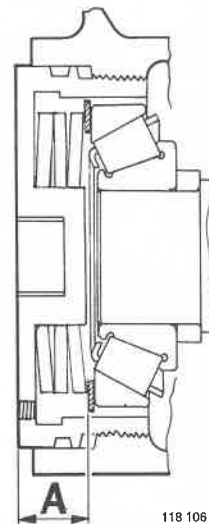

Fig. 92-84. Cover measurement

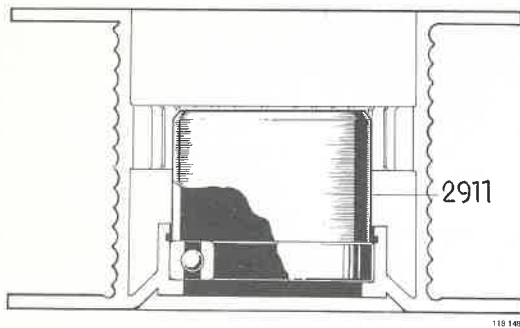

Fig. 92-85. Pressing in the bearing

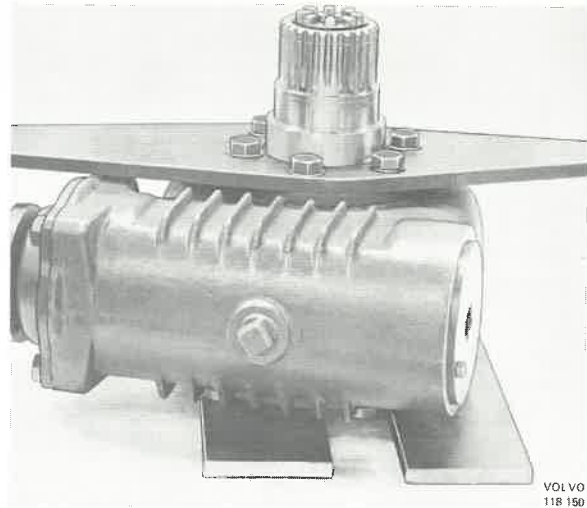

Fig. 92-87. Placing the gear housing

21. Place the support shaft in the bracket.
22. Coat the gear housing contact surface against the support shaft with sealing agent. Bolt the housing to the support shaft, see Fig. 92-83, and tighten to a torque of 55-90 Nm (5,5-9 kpm = 40-65 lbftf).
23. Remove the bolt in the trailing cover hole. Screw in the cover so that the measurement A measured through the hole is 20.1 mm (0.8"), see Fig. 92-84. Screw in the bolt.
24. Coat the sealing surface on the cover for the worm gear housing with sealing agent. Fit it in the housing, note the marking, and tighten up with the bolts.

25. Press the bearing into the cable drum with 2911, see Fig. 92-85. Fit the lock ring.
26. Press the seal into the drum with 6109, see Fig. 92-86. Coat the lips on the seal with sealing agent.
27. Place the gear housing with something underneath as shown in Fig. 92-87, so as not to damage the air valve.
28. Lift the cable drum, by using 2628. Remove 2628 and drive down the drum with 2500, see Fig. 92-88.
29. Place the planetary gear cage in the drum. Secure the lock ring holding it.

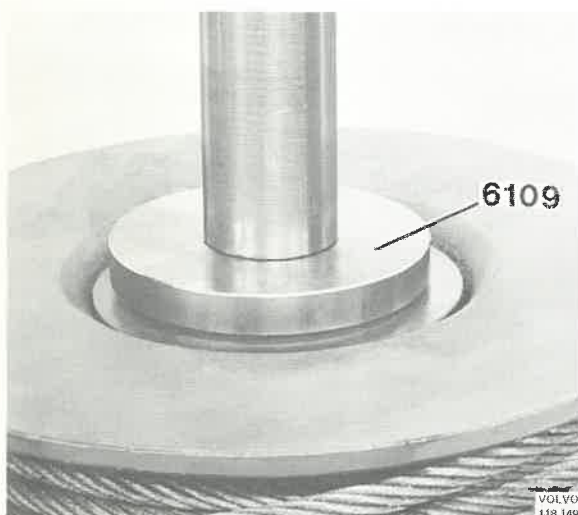

Fig. 92-86. Pressing in the seal

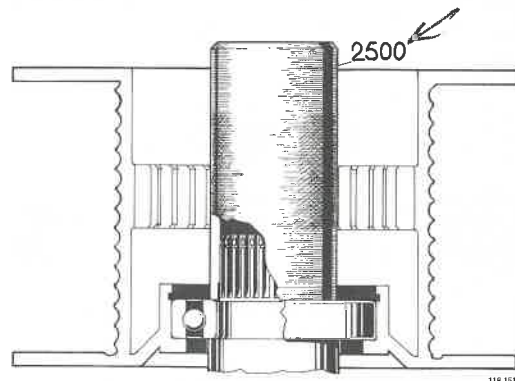

Fig. 92-88. Fitting the cable drum

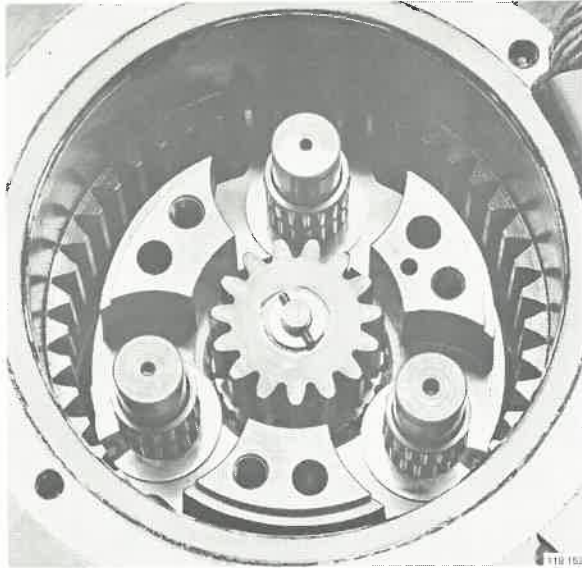

Fig. 92-89. Fitting the needle bearings

30. Fit the sun gear with the pull rod. Place the washers on the shafts, making sure that the lock tabs fit the recesses in the cage.
31. Fit the needle bearings in position, see Fig. 92-89.
32. Place the planetary gears and washers in position.
33. Fit the cover. Make sure that the tabs on the planetary gear washers fit properly in the cover.
34. Fit the lock washers for the shafts in position. Tighten up the washers. Tighten up the cover.

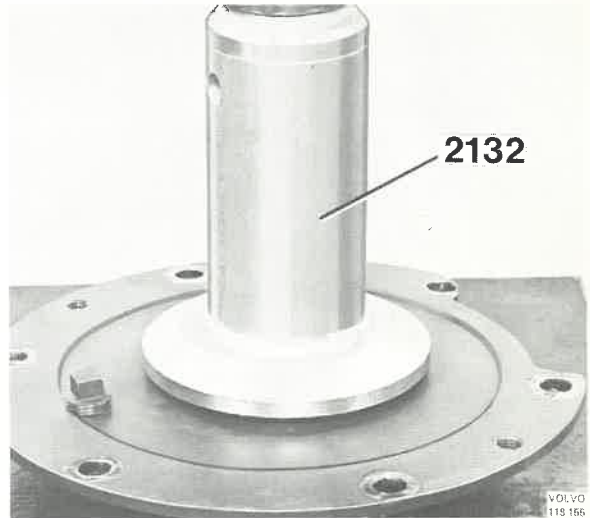

Fig. 92-91. Pressing in the seal

35. Press the bearing into the cable drum cover with 6117, see Fig. 92-90.
36. Press the seal into the cover with 2132, see Fig. 92-91.
37. Tighten up the cover on the cable drum.
38. Adjust the control unit, see under "Adjusting the control unit".

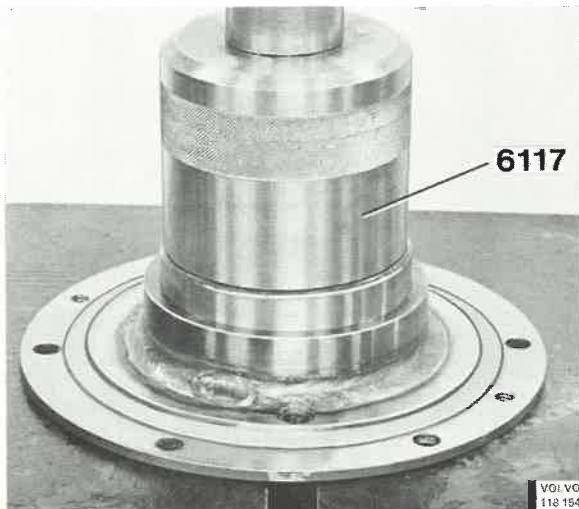
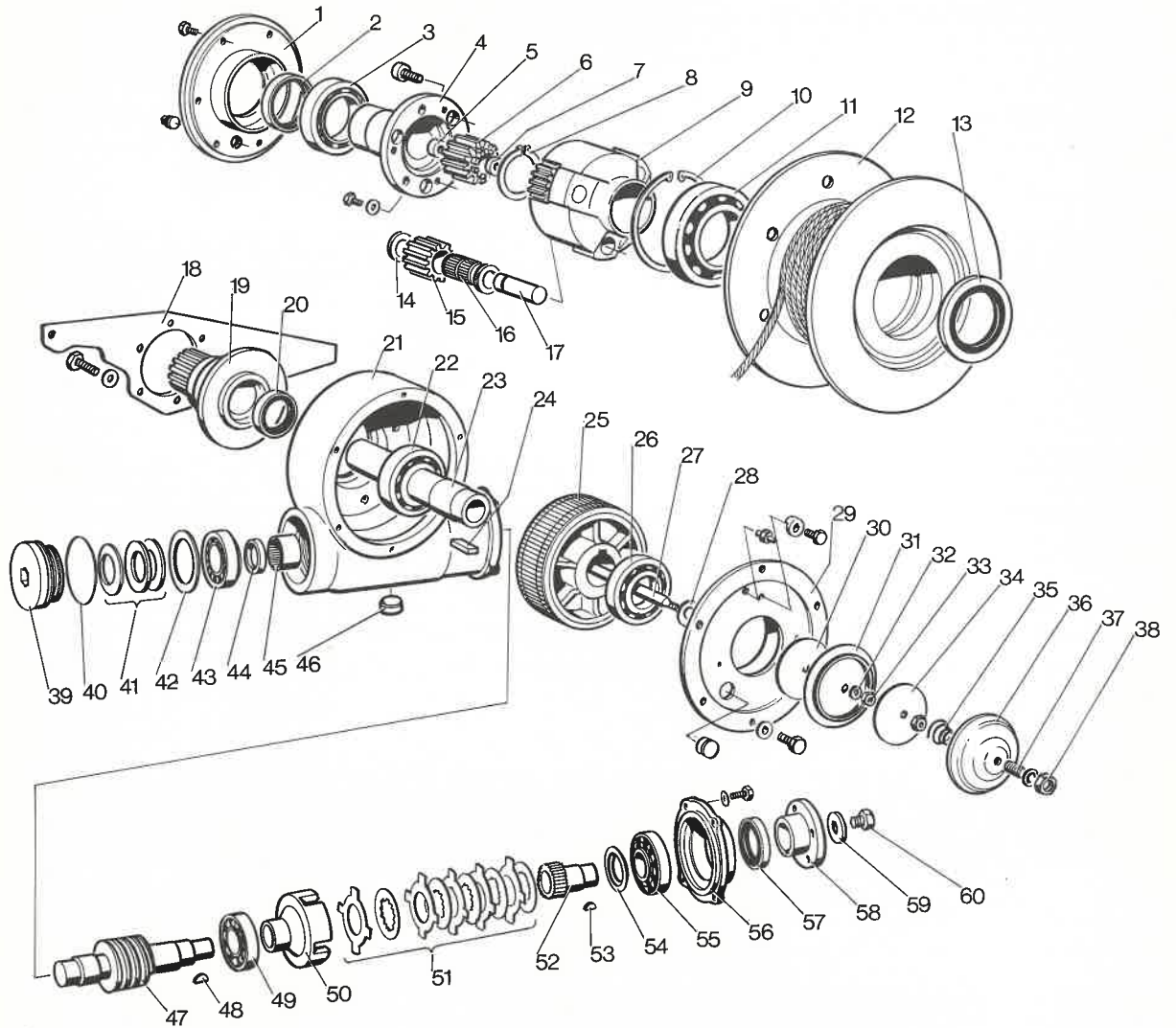

Fig. 92-90. Pressing in the bearing

Illustration A



- | | | |
|------------------------|--------------------|--------------------|
| 1. Cover | 21. Gear housing | 41. Washer spring |
| 2. Seal | 22. Bearing | 42. Spacer ring |
| 3. Bearing | 23. Shaft | 43. Bearing |
| 4. Cover | 24. Key | 44. Spacer washer |
| 5. Washer | 25. Worm gear | 45. Needle bearing |
| 6. Sun gear | 26. Bearing | 46. Drain plug |
| 7. Washer | 27. Thrust rod | 47. Worm |
| 8. Circlip | 28. Washer | 48. Key |
| 9. Planetary gear cage | 29. Cover | 49. Bearing |
| 10. Circlip | 30. Thrust washer | 50. Flange |
| 11. Bearing | 31. Diaphragm | 51. Discs |
| 12. Cable drum | 32. Spacer, washer | 52. Inputshaft |
| 13. Seal | 33. Nut | 53. Key |
| 14. Washer | 34. Thrust washer | 54. Spacer washer |
| 15. Planetary gear | 35. Spring | 55. Bearing |
| 16. Needle bearing | 36. Cover | 56. Cover |
| 17. Shaft | 37. Bolt | 57. Seal |
| 18. Bracket | 38. Nut | 58. Flange |
| 19. Support shaft | 39. Cover | 59. Washer |
| 20. Seal | 40. O-ring | 60. Bolt |

Illustration B

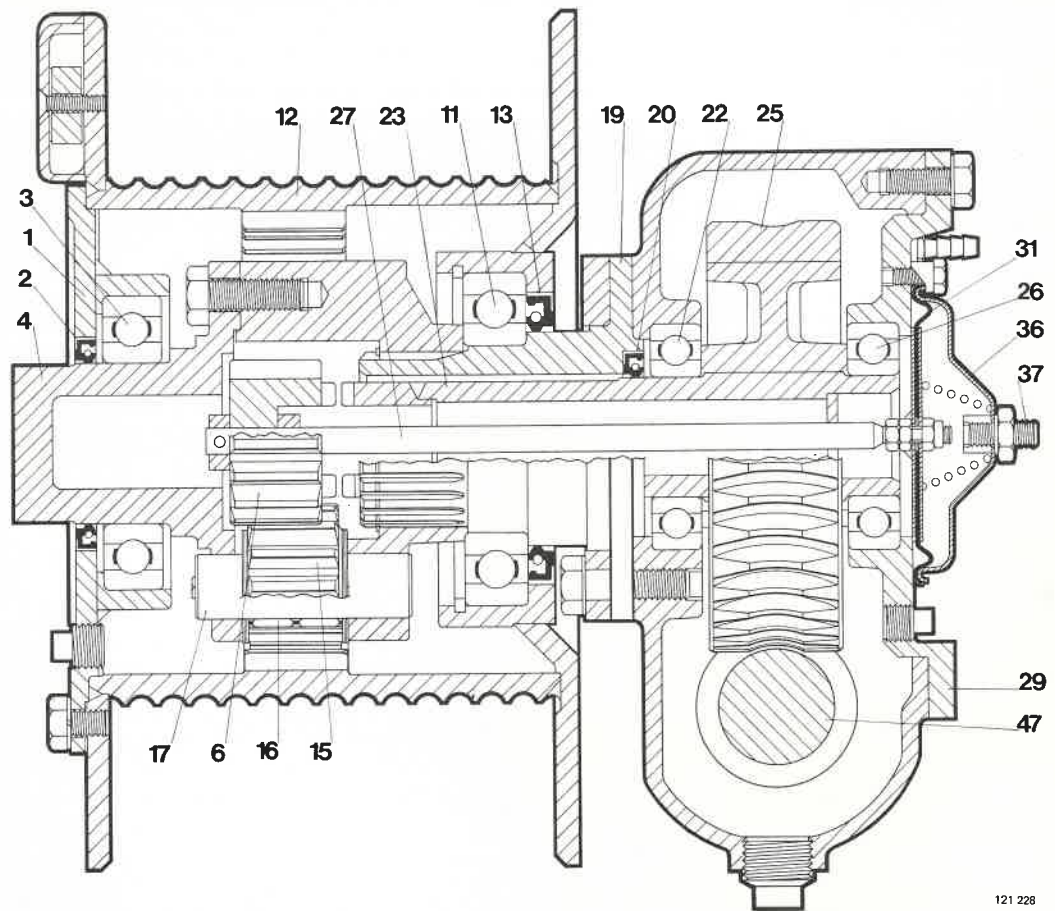

121 228

- | | | |
|----------------|--------------------|----------------|
| 1. Cover | 15. Planetary gear | 26. Bearing |
| 2. Seal | 16. Needle bearing | 27. Thrust rod |
| 3. Bearing | 17. Shaft | 29. Cover |
| 4. Cover | 19. Support shaft | 31. Diaphragm |
| 6. Sun gear | 20. Seal | 36. Cover |
| 11. Bearing | 22. Bearing | 37. Bolt |
| 12. Cable drum | 23. Shaft | 47. Worm |
| 13. Seal | 25. Worm gear | |

Illustration C

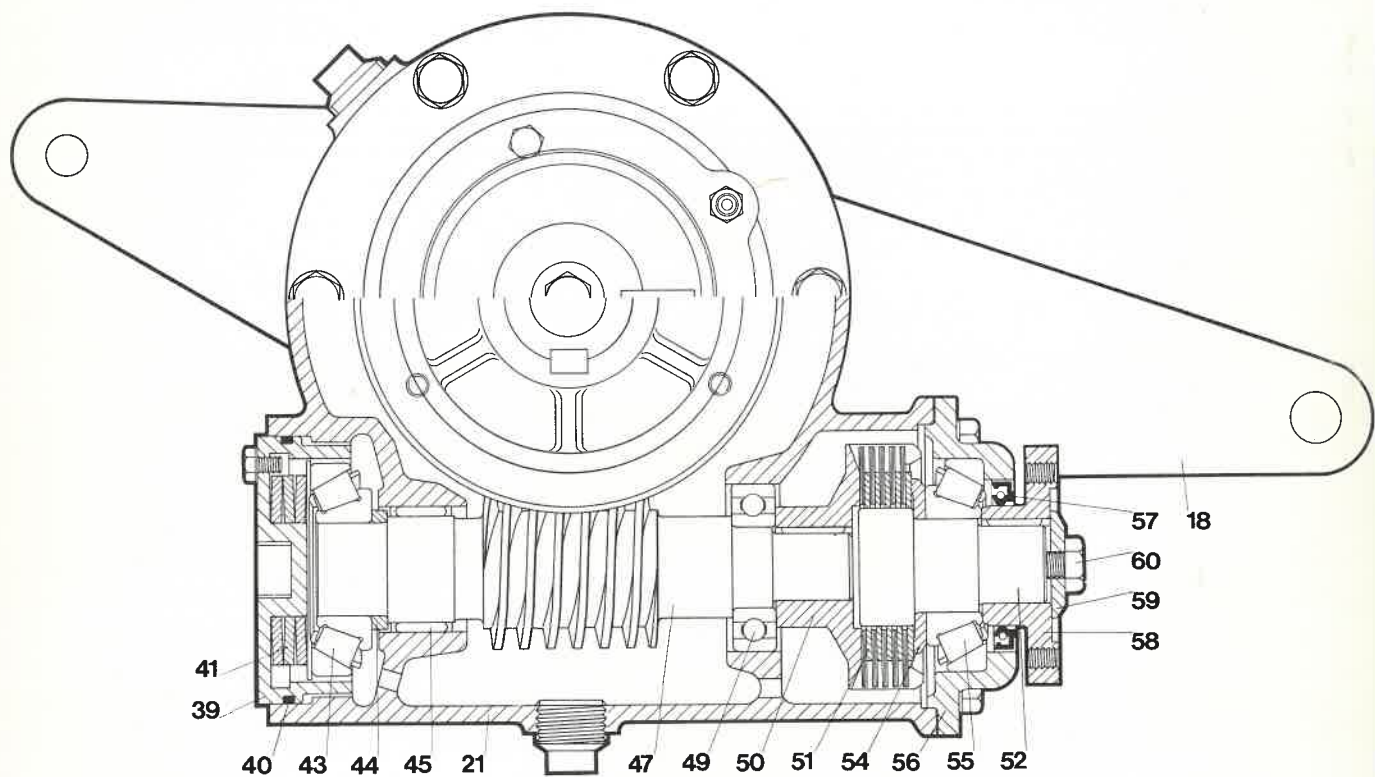

- 18. Bracket
- 21. Gearing housing
- 39. Cover
- 40. O-ring
- 41. Washer spring
- 43. Bearing
- 44. Spacer washer

- 45. Needle bearing
- 47. Worm
- 49. Bearing
- 50. Flange
- 51. Discs
- 52. Input shaft
- 54. Spacer washer

- 55. Bearing
- 56. Cover
- 57. Seal
- 58. Flange
- 59. Washer
- 60. Bolt

