



PART 4  
POWER  
TRANSMISSION  
C3-series

# **SERVICE MANUAL**

## CONTENTS

### GROUP 40 GENERAL

Data	1
Special tools	5
Description	6

### GROUP 41 CLUTCH

Description	1
Service Procedures	1
Clutch work in vehicle	1
Clutch pedal	1
Clutch wire	1
Reconditioning	2
Illustration A	5

### GROUP 42 MANUAL GEARBOX

Description	1
Service Procedures	5
Work on transmission in vehicle	5
Auxiliary gearbox	5
Gearbox	10
Removing	10
Disassembling	12
Checking and replacing parts	19
Assembling	19
Installing	30
Auxiliary gearbox	32
Removing	32
Disassembling	34
Checking and replacing parts	39
Assembling	39
Installing	49
Illustration A Gearbox	53
B Gearbox	55
C Gearbox	57
D Auxiliary gearbox	59
E Auxiliary gearbox	61

### GROUP 45 PROPELLER SHAFTS

Description	1
Service Procedures	1

### GROUP 46 REAR AXLE AND FRONT AXLE

Description	1
Service Procedures	4
Differential carriers	4
Work on diff. carriers in vehicle	4
Diff. carriers, diff. locks	4
Replacing diff. carriers	7
Removing front diff. carrier	7
Installing front diff. carrier	8
Removing rear diff. carrier	9
Installing rear diff. carrier	10
Replacing diff. sleeve	11
Disassembling diff. carriers	11
Checking and replacing parts	14
Assembling	14
Wheel Carriers	21
Front wheel carriers	21
Removing wheel carrier	21
Replacing rubber bellows, wheel carrier	22
Replacing drive shaft joint	22
Reconditioning drive shaft joint	23
Reconditioning wheel carrier	25
Installing wheel carrier	28
Rear wheel carrier	30
Removing wheel carrier	30
Reconditioning wheel carrier	31
Installing wheel carrier	34
Power take-off	35
Removing	35
Disassembling	35
Assembling	37
Installing	40
Illustration A Differential carriers	41
B Differential carriers	43
C Wheel carriers, front	45
D Wheel carriers, front	47
E Wheel carriers, rear	49
F Wheel carriers, rear	51
G Power take-off	53
H Power take-off	55

### GROUP 48 POWER TAKE-OFF

Description	1
Service Procedures	2
Removing	2
Disassembling	3
Checking and replacing parts	6
Assembling	6
Installing	8
Illustration A	9
B	11

# GROUP 40 GENERAL

## Data

### CLUTCH

Clutch type	Single disc, dry plate
Size	9 1/2"
Friction surface	456 cm <sup>2</sup>
Spring type	Disc spring
Rivets for clutch lining, number	36
size	3.6 x 5.2 mm (0.142–0.205")
Withdrawal lever free play	5 mm (0.20")
Maximum permissible taper, thrust plate	0.025 mm (0.0010")

### GEARBOX

Type designation	S 4 18/3 ZF
Reduction ratios:	
1st gear	3.87:1
2nd gear	2.08:1
3rd gear	1.39:1
4th gear	1:1
reverse	4.16:1
Shims, bearing — input shaft, alt.	0.5–1.5 (in stages 0.1 mm = 0.020–0.060") 0.0039")
cover — input shaft, alt.	0.4–1.0 (in stages 1 mm = 0.016–0.039") 0.0039")
cover — bearing, countershaft, alt.	0.5–1.5 (in stages 0.1 mm = 0.020–0.060") 0.0039")
cover — bearing, output shaft	0.4–1.0 (in stages 0.1 mm = 0.016–0.039") 0.0039")
Circlip, output shaft	1.8, 1.9 and 2.0 mm (0.071, 0.075 and 0.080")
Axial clearances, cover — bearing, input shaft	± 0.05 mm (0.0020")
bearing — input shaft	0.0 ± 0.1 mm (0.0039")
cover — bearing, countershaft	+ 0.1 mm (0.0039")
cover — bearing, output shaft	± 0.05 mm (0.0020")
Oil change quantity	1.2 litres (2 pints)
Oil type	Gear oil API-GL-1 SAE 80 or SAE 80/90

### Tightening torques

Nut, output shaft	140–160 Nm (14–16 kpm = 101–115 lbftf)
Nuts, housing pistons	20– 25 Nm (2.0–2.5 kpm = 14–18 lbftf)
Allen bolts, housing pistons	8– 12 Nm (0.8–1.2 kpm = 5.8–8.7 lbftf)
Bolts, front cover	22– 25 Nm (2.2–2.5 kpm = 15–18 lbftf)
Nuts, clutch casing	41– 51 Nm (4.1–5.1 kpm = 30–37 lbftf)
Nuts, auxiliary gearbox — gearbox	23– 28 Nm (2.3–2.8 kpm = 17–20 lbftf)

**AUXILIARY GEARBOX**

Type designation	FD 51
Reduction ratio:	
Low gear	2.39:1
High gear	1:1
Shims, bearing — rear cover, alt.	0.10, 0.15, 0.35 and 0.50 mm (0.0039, 0.0060, 0.0140 and 0.020")
Circlip, alt.	1.9 and 2.0 mm (0.075 and 0.080")
End play, intermediate gear	0.01–0.05 mm (0.0004–0.0020")
output shaft	0.03–0.08 mm (0.0012–0.0031")
control mechanism flange	0.1 mm (0.0039")
pull rod — cover bolt	approx. 8 mm (0.31") or 5.3 turns
Oil change quantity	1,3 litre ( 2,3 pints.)
Oil type	Gear oil API-GL-16 SAE 80 or SAE 80/90
Tightening torques:	
nut, output shaft	100–120 Nm (10–12 kpm = 72–87 lbftf)
nut, countershaft	100–120 Nm (10–12 kpm = 72–87 lbftf)

**PROPELLER SHAFTS**

Type designation	1300
Lubricant	Grease MP
Tightening torque:	
flange bolts	55–65 Nm (5.5–6.5 kpm = 40–48 lbftf)

**DIFFERENTIAL CARRIER**

Type designation	EV II
Reduction ratio	2.91:1
Shims, spacer sleeve-bearing pinion	0.08 mm (0.003") 0.13 mm (0.005") 0.25 mm (0.010") 0.75 mm (0.030")
Shims, bearing-pinion	0.08 mm (0.003") 0.13 mm (0.005") 0.25 mm (0.010")
Thrust washers, diff. side gears	0.74–0.98 (in stages 0.04 mm (0.029–0.039") = 0.0016")
Oil change quantity	1.5 litres (2,6 pints.)
Oil type	Rear axle oil API-GL-5 or MIL-L-2105B, SAE 80

## Tightening torques:

pinion nuts: . . . . .	280–300 Nm	(28–30 kpm = 202–217 lbftf)
bolts, crown wheel . . . . .	80–100 Nm	(8–10 kpm = 58–72 lbftf)
caps . . . . .	55– 67 Nm	(5.5–6.7 kpm = 40–48 lbftf)

**WHEEL CARRIERS**

Reduction ratio . . . . .	2.06:1	
Oil change quantity, wheel carrier, front . . . . .	0.3 litre	(0,5 pints)
rear . . . . .	0.4 litre	(0,7 pints)
Oil type: . . . . .	Gear oil API-GL-1 SAE or SAE 80/90	

## Tightening torques:

bolts, rear axle casing-wheel carrier housing . . . . .	100–120 Nm	(10–12 kpm = 72–87 lbftf)
front axle casing . . . . .	100–120 Nm	(10–12 kpm = 72–87 lbftf)

**POWER TAKE-OFF, rear axle**

Reduction ratio . . . . .	1:1	
Shims, drivegear . . . . .	1.25, 1.30, 1.35, 1.40, 1.60, 1.65, 1.85, 1.90, 1.95, 2.00 mm.	
Axial clearances, drivegear bearing . . . . .	0.03–0.08 mm	
Tightening torques:		
not, output shaft . . . . .	100–120 Nm	(10–12 kpm = 72–87 lbftf)
not, drive gear . . . . .	25–41 Nm	(2.5–4.1 kpm = 15–30 lbftf)

**POWER-TAKE-OFF**

Reduction ratio . . . . .	1:1	
Oil change quantity . . . . .	0,2 litre	(0,4 pints)
Tightening torques:		
bolts, output shaft . . . . .	41–51 Nm	(4.1–5.1 kpm = 30–37 lbftf)
bolts, front housing and housing half . . . . .	20–25 Nm	(2.0–2.5 kpm = 14–18 lbftf)

The following special tools are required for work on the clutch, gearbox, auxiliary gearbox, differential carriers, wheel carriers, power take-off differential carriers, power take-off auxiliary gearbox.

	Clutch	Gearbox	Auxiliary gearbox	Diff. carriers	Wheel carriers	Power take-off auxiliary gearbox	Power take-off diff. carriers
1426	Drift	X					
1784	Drift		X			X	
1801	Standard handle	X	X	X		X	X
1817	Extractor		X				
1821	Extractor				X		
1845	Press tool		X	X			
2014	Drift		X			X	
2022	Sleeve		X		X	X	X
2039	Drift		X				
2097	Extractor		X		X		
2116	Puller		X				
2132	Drift		X		X		
2261	Extractor		X	X		X	X
2267	Drift		X				X
2284	Retainer			X			
2291	Drift		X				
2337	Drift		X				
2370	Extractor			X	X		
2392	Extractor			X			
2395	Drift		X	X			
2404	Spanner			X			
2413	Drift				X		
2490	Drift						X
2520	Stand		X				
2564	Drift	X	X				
2567	Extractor			X			
2584	Sleeve				X		
2600	Measuring fixture			X			
2636	Holder			X			
2685	Adjusting ring			X			
2686	Press tool			X			
2806	Drift		X	X			
2837	Counterhold		X	X			X
2841	Socket spanner			X			
4030	Extractor	X	X				X
4090	Extractor	X	X				
6011	Drift		X				
6012	Drift		X				
6024	Drift		X				
6100	Extractor		X				
6101	Fixture		X				
6102	Sleeve		X	X			
6103	Press tool		X				
6104	Drift		X				
6105	Drift		X				
6108	Drift		X			X	
6109	Plate		X			X	
6110	Sleeve		X			X	X
6111	Sleeve		X				
6112	Fixture			X			
6113	Measuring tool			X			
6114	Drift			X			
6115	Drift			X			
6116	Drift		X	X			
6117	Sleeve				X		
6120	Guide		X				
6122	Ring		X				X
6126	Bleeder tool			X	X		
6128	Spanner	X	X	X			
6129	Lifting eyelet	X	X	X			
6131	Guide pin			X	X		
6133	Gauge			X	X		
6135	Spanner			X	X		
6136	Lifting tool	X	X	X			
6137	Lifting eyelet		X	X			
6140	Fixture		X				
6141	Separating bolt			X	X	X	
6145	Centring drift	X					
6146	Parallel block			X			

C3-series

uxiliary gearbox, differential carriers,  
earbox.

Power  
take-off  
diff.  
carriers

X

X

X  
X

X

X  
X

X

X

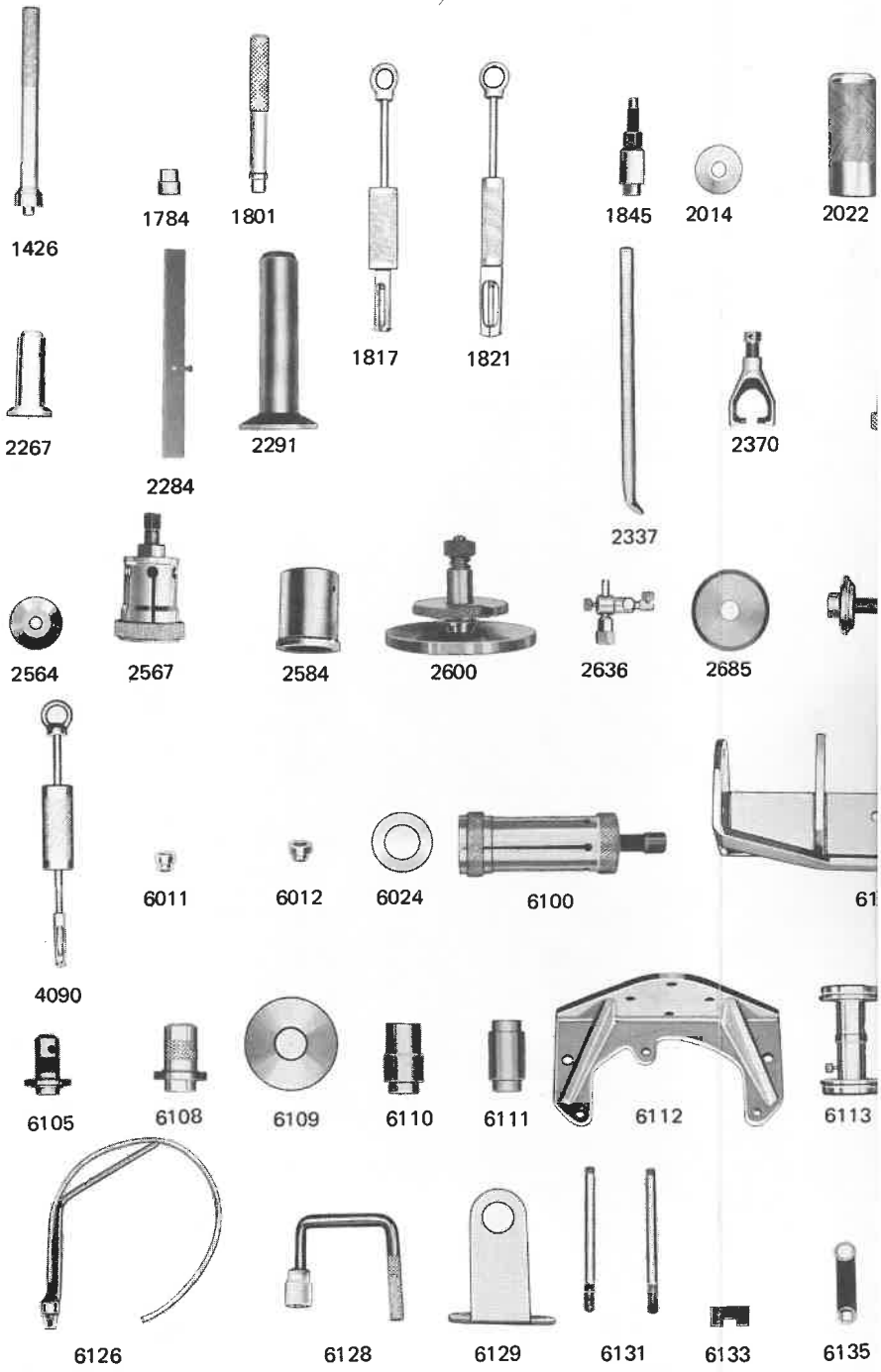


Fig. 41-1. Special tools

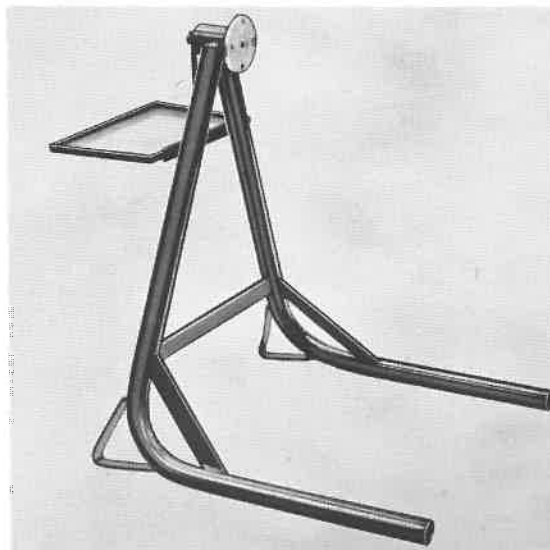


Fig. 40-2. Stand 2520 u

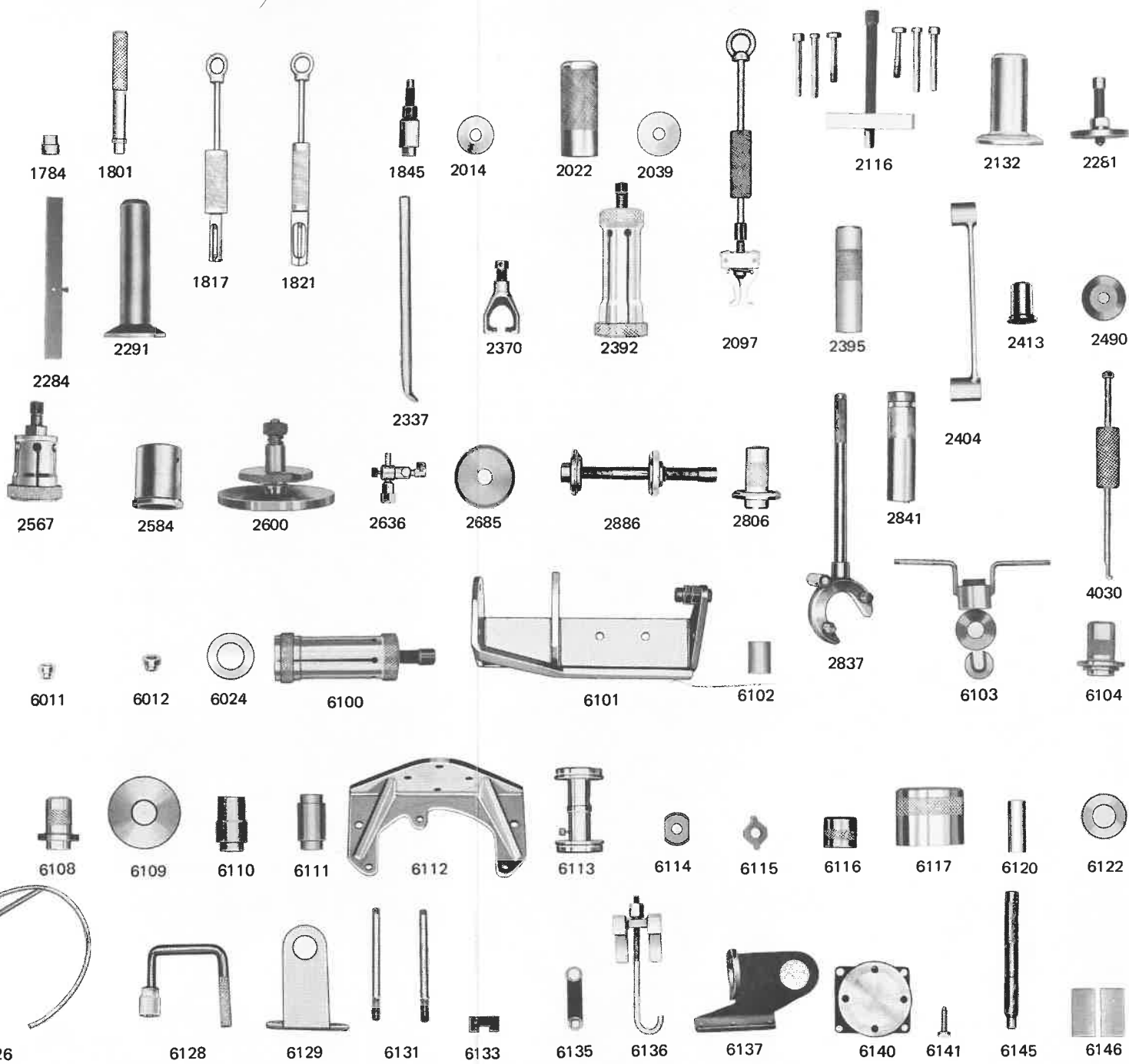


Fig. 41-1. Special tools

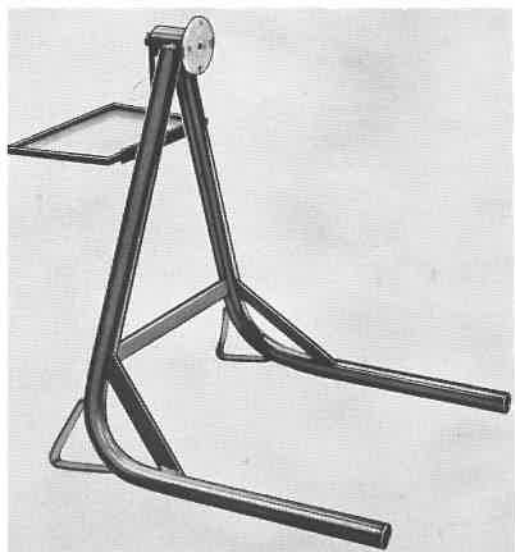


Fig. 40-2. Stand 2520 used together with 6101, 6112, 6140

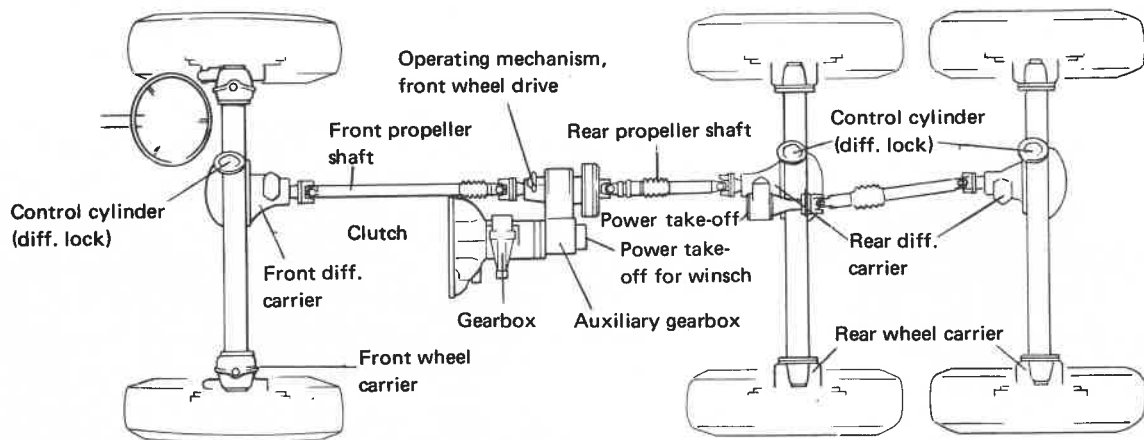
## Description

The power transmission for the 2-axle vehicle consists of a clutch, gearbox, auxiliary gearbox, propeller shaft sections and a front and rear axle with differential carries and wheel carries, see Fig. 40-3. In addition to an extra rear axle on 3-axle trucks, there is a power take-off for driving this rear axle. The description and repair instructions for these components are to be found in their respective groups.

In order to prevent dirt and impurities from getting into the evacuation systems in the auxiliary gearbox, gearbox, front and rear axle casings, evacuation is by means of a common hose which runs up to the engine compartment, see Fig. 40-4. Extra sealing has been

introduced between the engine and clutch casing and the casing has an evacuation which is connected to the other evacuation system. The sealing between the engine and casing consists of a plate with two washers, see Fig. 40-5. The plate is situated between the oil sump and the engine block and the washers are placed between the reinforcing bracket and the sump, see Fig. 40-6.

The cylinder for engaging the front wheels and the cylinders for operating the differential locks for the front and rear differential carriers are operated by vacuum and for this reason the frame crossmembers have been utilized as vacuum reservoirs, see Fig. 40-7.



VOLVO  
117 099

Fig. 40-3. Power transmission

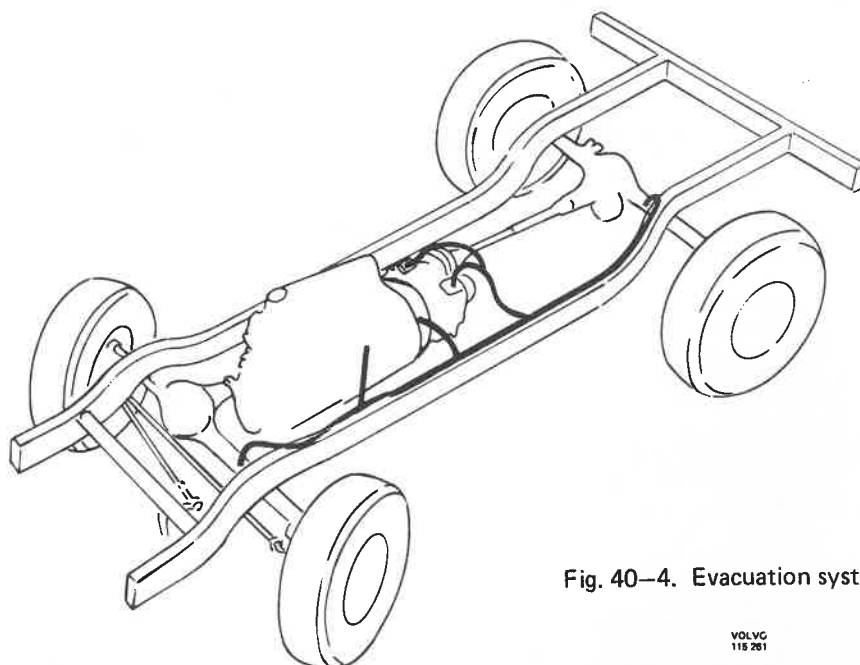


Fig. 40-4. Evacuation systems

VOLVO  
118 261

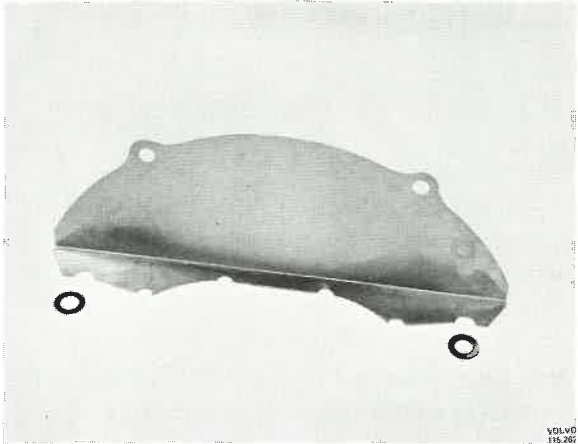
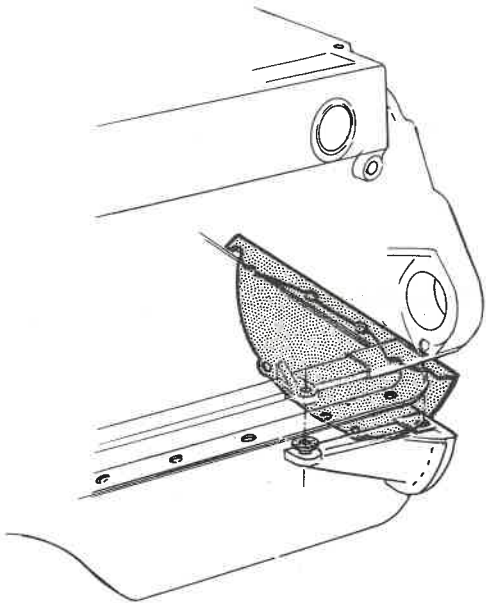


Fig. 40-5. Requisite sealing between engine and gearbox



VOLVO  
115 263

Fig. 40-6. Location of seals

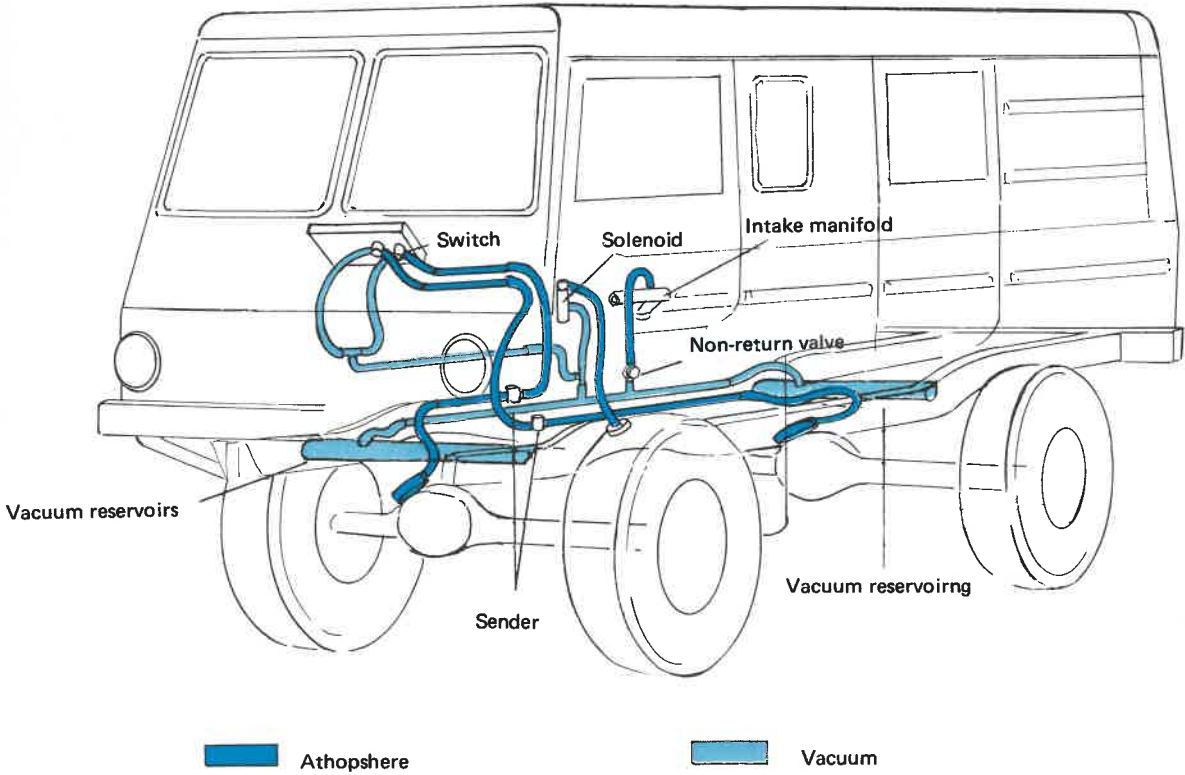


Fig. 40-7. Vacuum system

## GROUP 41 CLUTCH

### Description

The clutch is of the disc-spring type, see Fig. 41-1. It consists of a thrust plate, disc spring and metal casing. The disc spring has a double function — partly that of a lever when disengaging the clutch and partly that of a thrust spring when engaging the clutch.

Clutching and declutching is by means of the clutch pedal, the movements of which are transmitted to the clutch via a wire, a lever and a release bearing. See illustration 41-A.

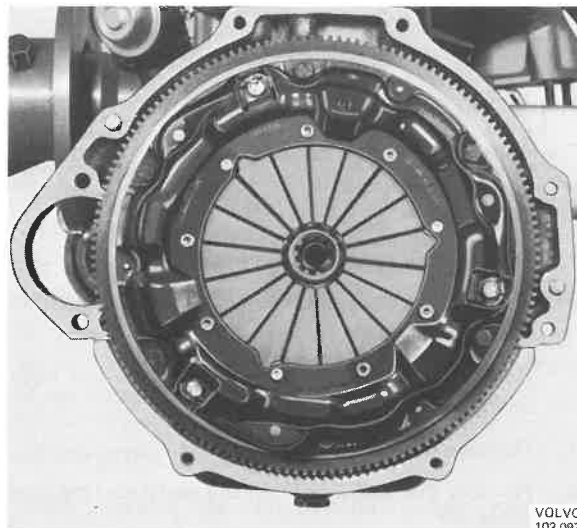


Fig. 41-1. Clutch

### Service procedures

#### CLUTCH WORK IN VEHICLE

##### Adjusting clutch pedal play

Correct clutch pedal play is obtained by adjusting the release lever, see Fig. 41-2, so that a play of about 5 mm (0.20"), A, is obtained. Play is adjusted by moving the clutch wire sleeve by means of the nuts (1) at the clutch casing attachment.

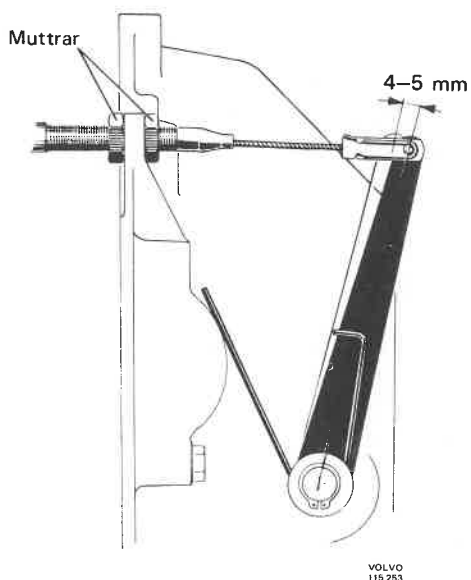


Fig. 41-2. Clutch lever play

##### Replacing clutch wire

1. Unhook the return spring for the release lever, see Fig. 41-3. Disconnect the wire from the lever.
2. Unscrew the rear nut and remove the wire sleeve from the clutch casing.
3. Disconnect the wire from the clutch pedal. Unscrew the nut for the wire sleeve. Remove the wire.

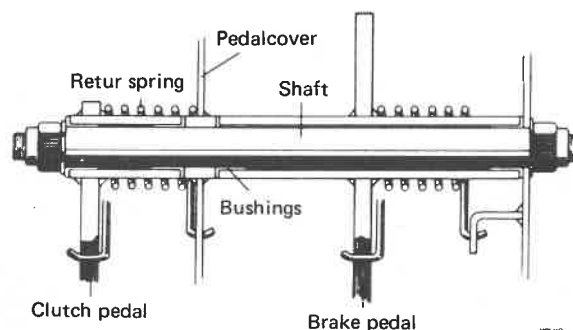


Fig. 41-3. Pedal carrier

4. Fix the wire to the clutch pedal. Secure the wire sleeve and tighten up the nut.
5. Fit the wire sleeve on the clutch casing and tighten up the nuts.
6. Fit the fork to the clutch lever. Adjust the play, see under "Adjusting clutch pedal play".

#### Replacing clutch pedal or bushings

The following description is applicable if it concerns either the replacement of the pedal or of the bushings.

1. Remove the stop bult, see Fig. 41-4.
2. Remove the wire and the return spring from the pedal.
3. Remove the nut and the washer on the pedal shaft.
4. Remove the pedal from the shaft.
5. Remove the bushings from the pedal and clean all parts.
6. Fit new bushings on the pedal and lubricate with universal grease.
7. Fit the spring on the pedal. Place the pedal in position and tighten up.
8. Hook on the return spring and the clutch wire.
9. Fit the stop bult.

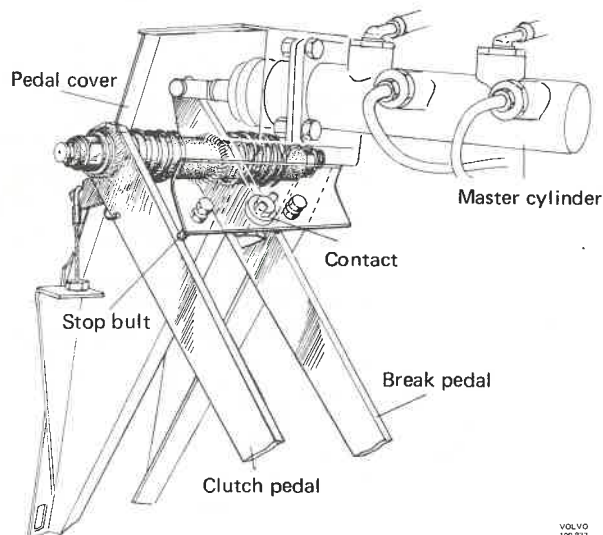


Fig. 41-4. Checking the curvature of thrust plate

## RECONDITIONING THE CLUTCH

### Removing

**NOTE!** Before removing the clutch, any external faults, wrongly adjusted clutch linkage, should first be checked and put right.

1. Remove the gearbox in accordance with the instructions given in Group 43, Gearbox.
2. Slacken the bolts holding the clutch to the flywheel by loosening them crosswise a couple of turns at a time to prevent warping. Remove the clutch and clutch plate.

### Replacing the release components

1. Remove the bolt in the release fork. Take out the release bearing. Pull out the release shaft.
2. If the clutch casing bushings have to be replaced, drive out the old bushings with a suitable drift, for example 1801.
3. Apply a light layer of grease to the release bearing sleeve and fit the bearing in position.
4. Fit a new seal on the release shaft and grease it. Hold the release fork in position and insert the release shaft. When the seal is compressed and the distance between the lever and casing is as shown in Fig. 41-5 then tighten up the bolt.

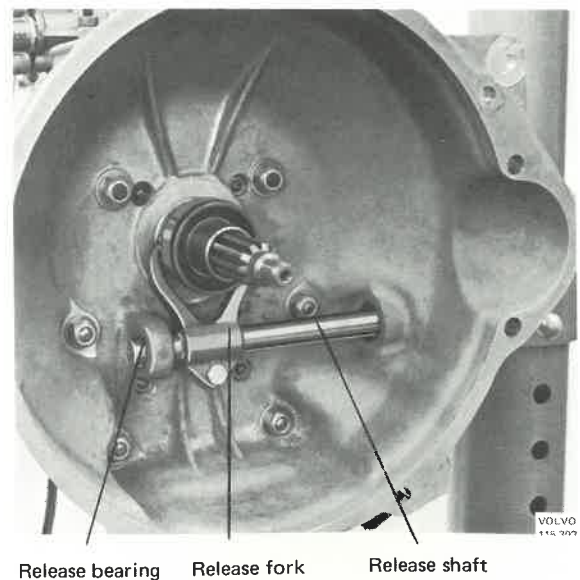


Fig. 41-5. Installing the clutch

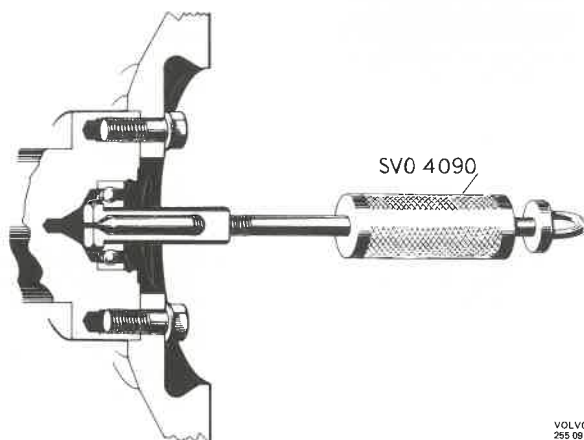


Fig. 41-6. Removing the bearing

### Replacing the input shaft pilot bearing

1. Remove the circlip from the bearing. Pull out the bearing with puller 4090, see Fig. 41-6.
2. Pack the bearing with heat-resistant grease. Drive it in with drift 1426. Fit the circlip.

### Replacing the clutch plate linings

1. Drill out the old rivets with a 3.4 mm (1/8") drill. Remove the old linings.
2. Check that the tabs on the linings are even. The linings must not be warped. The lining springs and rivets on the hub should be firmly fitted and should not be loose. Check for cracks. If any of these faults are to be found, replace the linings.
3. Rivet on the new linings (preferably in a rivet press). NOTE! The rivets should be fitted from the side where the lining is and should be riveted from the opposite side towards the disc. Use every alternative hole in the lining. After the riveting, the linings should have a distance from each other which is determined by the layout of the clutch disc. This is very important in order to obtain smooth clutching during driving and starting off.

The clutch linings must be absolutely free from oil. Oil on the linings can result in clutch judder.

### Checking and replacing parts

Check the clutch thoroughly. Check the thrust plate for heat damage, cracks, scoring or other damage on the friction surface. If the clutch is only blued, it is not necessary to replace it. Circular scoring can be tolerated if the thrust plate friction surface has not been reduced by more than 10% and the depth of the scoring does not exceed 1 mm (0.039"). This also applies to the flywheel. The dish design of the thrust

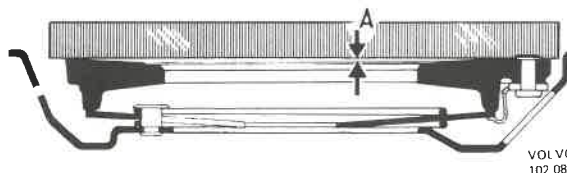


Fig. 41-7. Checking thrust plate dished design

A = max. 0.03 mm

plate can be checked by means of a 240 mm (9.5") long steel ruler, which is placed across the thrust plate friction area. Then measure the distance between the ruler and the thrust plate inner diameter. This measurement should be max. 0.03 mm (0.0012"), (A, Fig. 41-7). Curvature, that is, clearance between the ruler and the outer diameter of the friction surface is not permitted. Check at several points.

### Installing the clutch

Before installing the clutch plate linings, check to make sure the flywheel and thrust plate are absolutely free from oil. Then clean with petrol and dry with a clean cloth.

1. Place the linings (the highest side of the hub facing towards the rear) together with the clutch against the flywheel and fit centering drift 6145 so that the guide pin on the drift reaches into the pilot bearing in the flywheel, see Fig. 41-8.
2. Fit the six bolts securing the clutch and tighten them crosswise and a couple of turns at a time. Remove the centering drift.
3. Install the gearbox according to the instructions given in Group 43, Gearbox. Adjust the clutch pedal play, see the separate instructions for this.

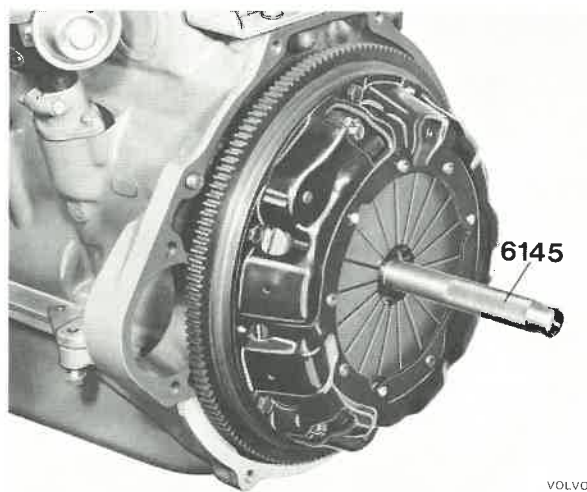
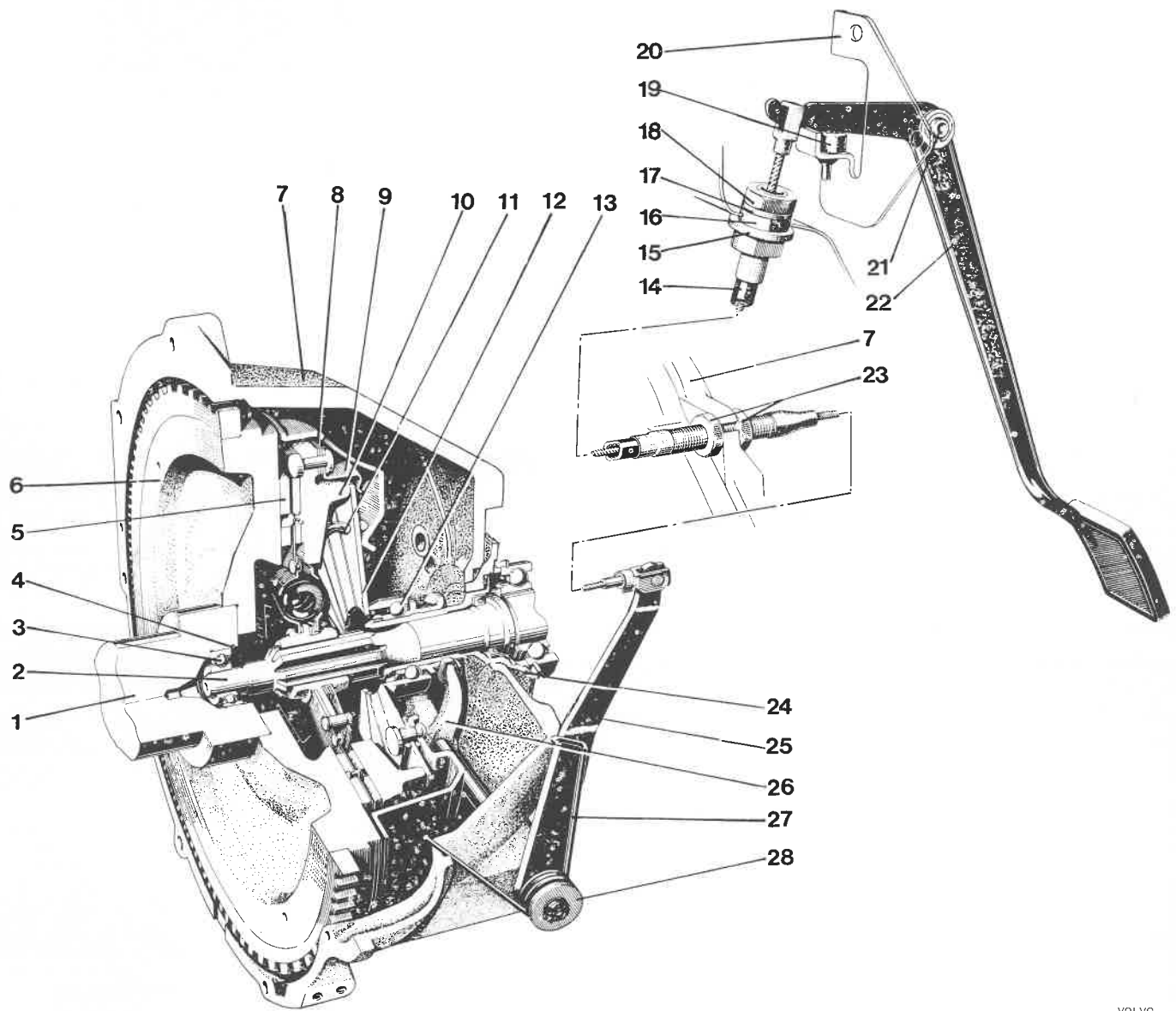


Fig. 41-8. Centring the clutch

**Illustration 41-A. Clutch**

**Clutch**

1. Crankshaft
2. Disc shaft (gearbox input shaft)
3. Support bearing in crankshaft
4. Circlip
5. Disc
6. Flywheel
7. Clutch casing
8. Cover
9. Retainer
10. Thrust plate
11. Support rings
12. Thrust spring
13. Throw-out bearing
14. Clutch wire
15. Washer
16. Rubber bushing
17. Washer
18. Nut
19. Rubber stop
20. Stop bracket
21. Pedal shaft
22. Clutch pedal
23. Adjusting nuts
24. Gearbox casing
25. Lever and throw-out shaft
26. Throw-out fork
27. Return spring
28. Washer



# GROUP 43 MANUAL GEARBOX

## Description

### GEARBOX

The gearbox, see Fig. 43-1, is a four-speed, synchronized gearbox with all gears except reverse synchronized. The synchronizing design can be seen from Fig. 43-2. Engaging and disengaging the synchronizing is shown in Figs. 43-3 and 43-4. Power from the gearbox to the differential carriers is transmitted by an auxiliary gearbox which is fixed to the rear end of the gearbox.

The gearbox design can be seen from Illustrations 43-A, B and C. The gearbox housing is in two sections one front and one rear, and is made of aluminium. The input and output shafts in the housing are journaled in ball bearings and the countershaft in roller bearings. The reverse shaft is not journaled and is driven directly in the housing. All gears are of the helical type and all except the gears for reverse shaft are in continuous mesh.

Gear-changing is by means of the gear lever, see Fig. 43-5, the movements of which are transmitted via a gear shift bar and link arms, see Fig. 43-6. The gear lever is also used for operating the auxiliary gearbox, and a special housing is mounted on the gearbox selector fork housing. The various gear positions and the path taken by the transmission in different gears can be seen from Figs. 43-7-43-11.

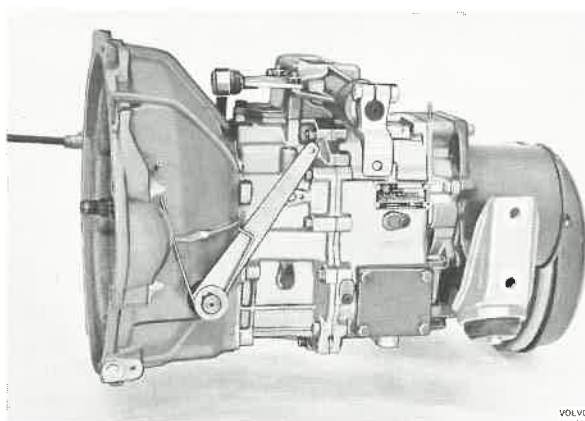


Fig. 43-1. Gearbox

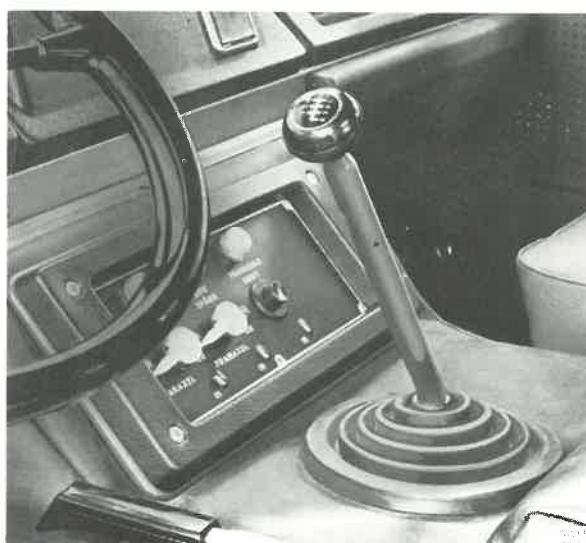
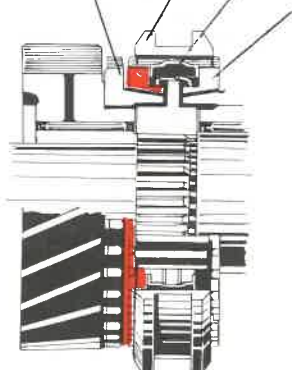


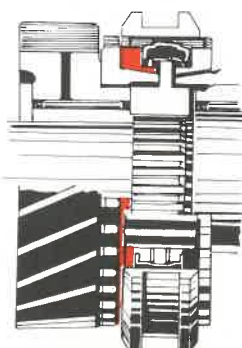
Fig. 43-5. Gear lever

Ring gear    Engaging sleeve  
Inhibitor  
Synchronizing cone



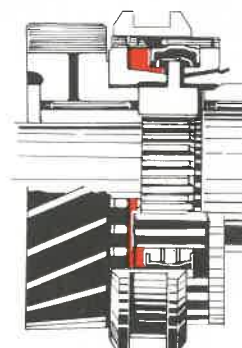
VOLVO  
115 264

Fig. 43-2. Synchronizing, neutral



VOLVO  
115 265

Fig. 43-3. Synchronizing



VOLVO  
115 266

Fig. 43-4. Gear engaged

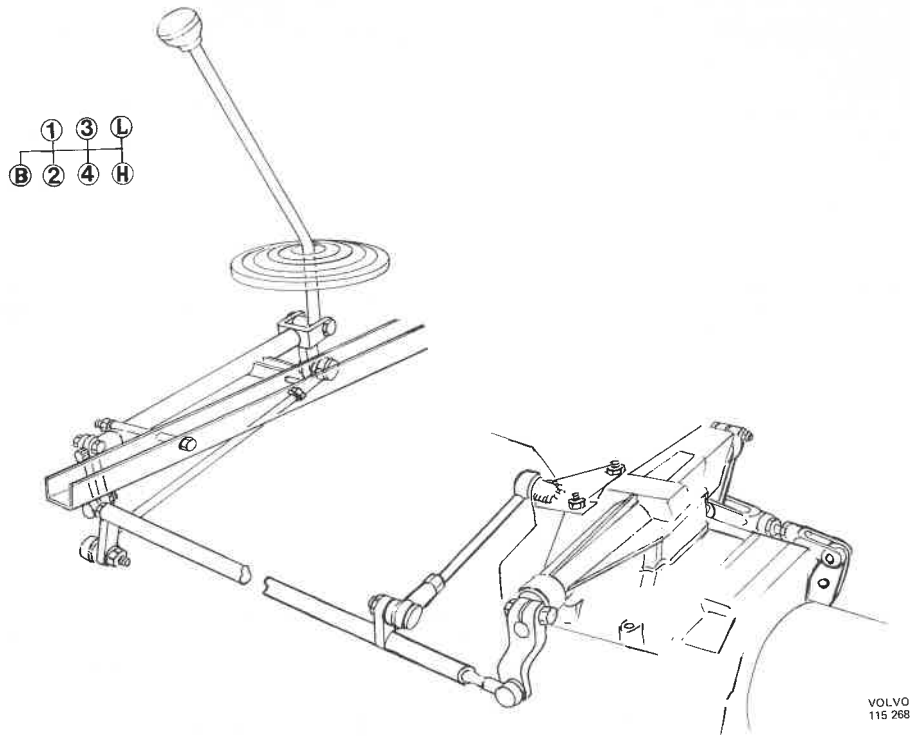


Fig. 43-6. Gear-change linkage

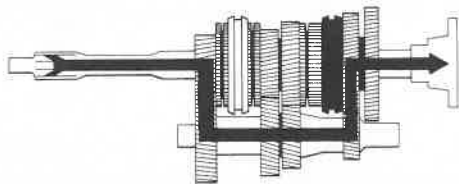


Fig. 43-7. 1st gear

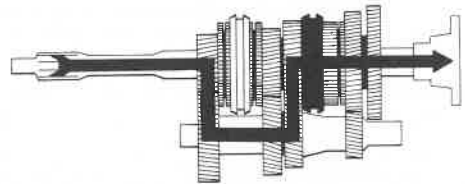


Fig. 43-8. 2nd gear

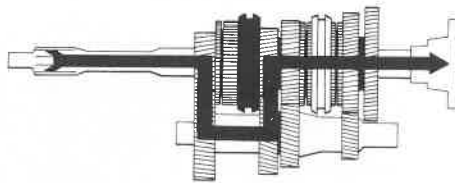


Fig. 43-9. 3rd gear

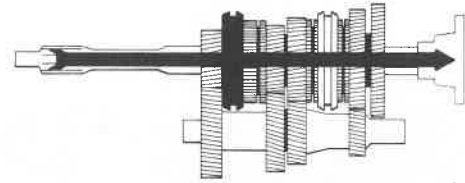


Fig. 43-10. 4th gear

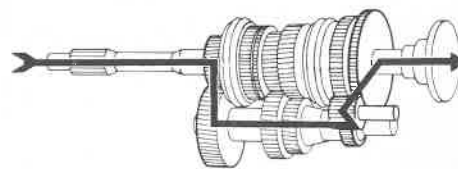


Fig. 43-11. Reverse

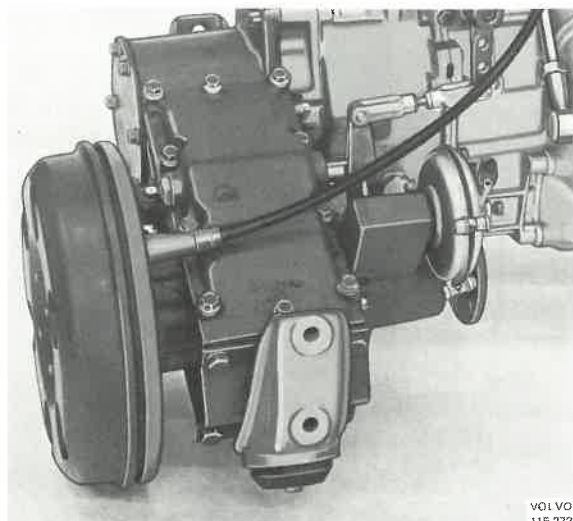


Fig. 43-12. Auxiliary gearbox

### AUXILIARY GEARBOX

The auxiliary gearbox, Fig. 43-12, has a high gear and a low gear and is synchronized on both. The synchronization is of the same type and size as that of the main gearbox.

The high gear is primarily intended for road driving and the low gear for cross-country driving.

The auxiliary gearbox is mounted on the rear end of the standard gearbox and its function is to transfer the power from the standard gearbox to the front or rear differential carriers. The gear lever for the standard gearbox is used for gear-changing the auxiliary gearbox. An indicator is situated on the dashboard, see Fig. 43-13, which shows the gear engaged.

When any of the auxiliary gearbox's gears is engaged, rear wheel drive is also engaged. Front wheel drive is engaged separately by means of the control mechanism at the front of the auxiliary gearbox, see Fig. 43-16.



Fig. 43-13. Indicator

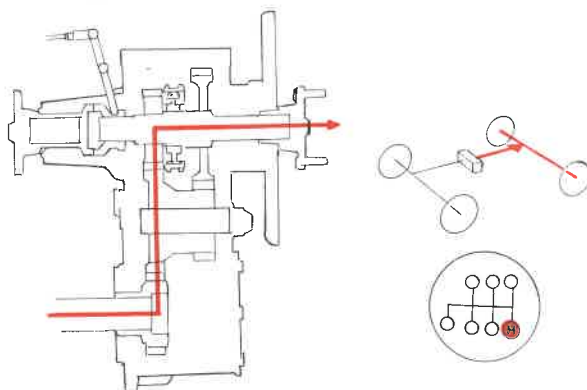


Fig. 43-14. High gear

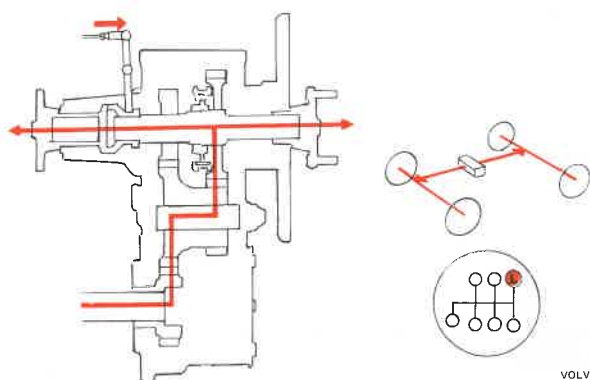


Fig. 43-15. Low gear

The auxiliary gearbox has a cluster gear, a counter-shaft and an output shaft. Power from the standard gearbox is transmitted via the cluster gear, which is linked to the auxiliary gearbox by means of a sleeve mounted on the output shaft for the standard gearbox. On the auxiliary gearbox output shaft there are two idler gears, one for the high speed and one for the low speed as well as a synchronizing unit. Fitted on the output shaft is a flange which is used for driving the rear wheels. Figs. 43-14 and 43-15 show

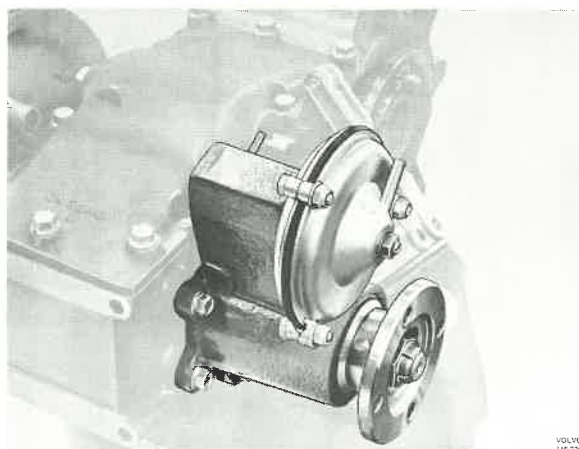


Fig. 43-16. Sleeve mounted.

VOLVO  
115 272VOLVO  
115 270VOLVO  
115 278

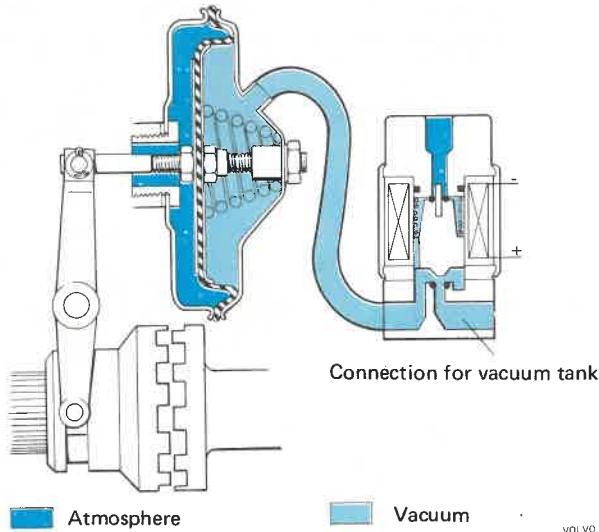


Fig. 43-17. Front wheel drive disengaged

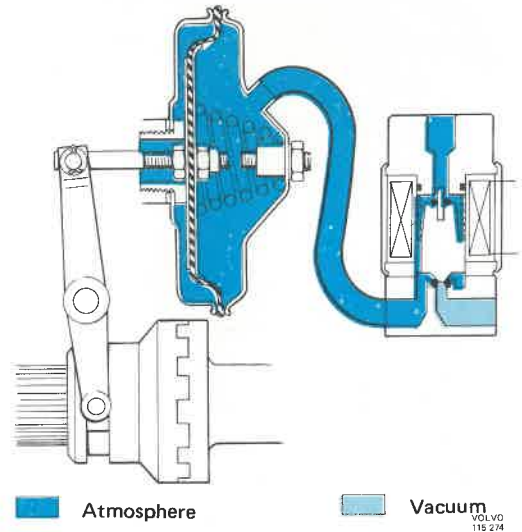


Fig. 43-18. Front wheel drive engaged

the path taken by the transmission when high speed or low speed is engaged. Fixed to the front end of the shaft is an engaging sleeve, which is used to engage the control mechanism, Fig. 43-16 for driving the front wheels. Engaging and disengaging the front wheel drive can take place in different ways and for this the following applies:

### FRONT WHEEL DRIVE

#### Disengaged position

When the solenoid valve is in current its armature is pulled upwards, see Fig. 43-17. This opens the connection between the vacuum tank in the frame and the control cylinder on the control mechanism. As a result of the vacuum in the diaphragm, the pull

rod pulls from the flange sleeve in the control mechanism and disengages the front wheel drive.

#### Engaged position

When there is no current through the solenoid valve, its armature is pressed down by the spring, Fig. 43-18. This breaks the connection between the vacuum tank and the control cylinder and the cylinder is connected up instead with the outside air. Since there is then atmospheric pressure on both sides of the diaphragm, the thrust spring in the cylinder can press in the pull rod to engage the flange sleeve and thus also engage the front wheel drive.

Front-wheel drive is also engaged when there is no vacuum.

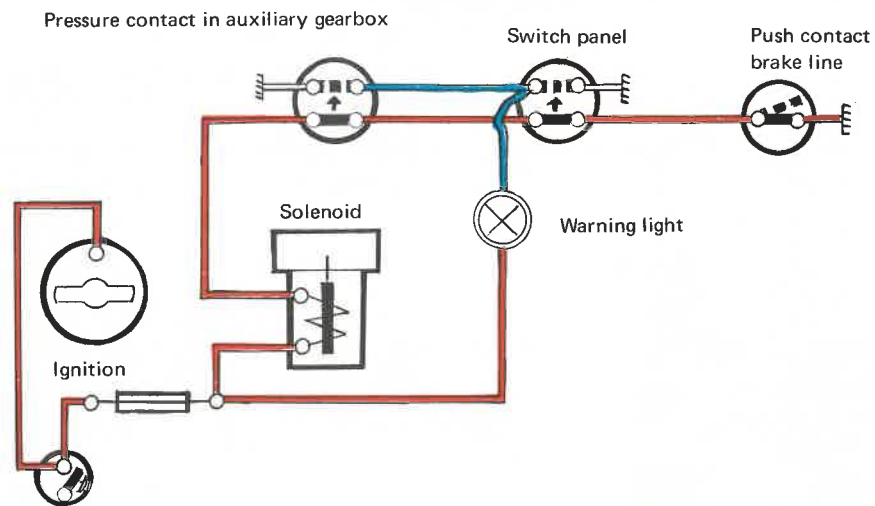


Fig. 43-19. Wiring diagram, front wheel drive

## Operation

As the above shows, disengaging and engaging of the front wheel drive is governed by the fact whether the solenoid valve is in current or not. Fig. 43-19 shows the wiring diagram and the various possibilities for operating the front wheel drive.

- A. Ignition. With the ignition key in neutral, the current circuit is broken and front wheel drive is thus engaged. Turning the key disengages the front wheel drive providing that there is vacuum in the frame tanks and the contacts and switch are in the position shown by Fig. 43-19.
- B. Gear lever. Engaging low gear breaks the contacts 50-50 in the auxiliary gearbox. This cuts out the current through the solenoid valve and front wheel drive is engaged. At the same time contacts 15-15 close and the control light goes on.



Fig. 43-20. Switch

- C. Panel switch see Fig. 43-20. Pushing in this switch breaks the contact 49-15. This cuts out the current through the solenoid valve and front wheel drive is engaged. At the same time switch 49a-R closes and the control light goes on.

## Service procedures

### WORK ON TRANSMISSION IN VEHICLE

Adjusting the gear-position indicator

1. Move the gear selector to neutral.
2. Slacken the nut securing the indicator arrow.
3. Turn the arrow so that it points to N. See Fig. 43-21 a.
4. Tighten up the nut.

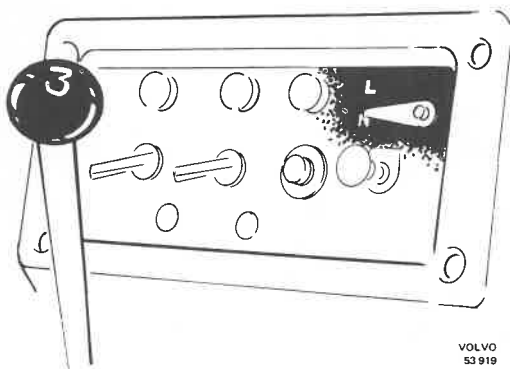


Fig. 43-21a. Indicator

### Auxiliary gearbox

Removing the cover

1. Remove the casing over the engine.
2. Remove the bolts securing the floor plate and remove the plate.
3. Remove the stowage box and cover over the engine casing.

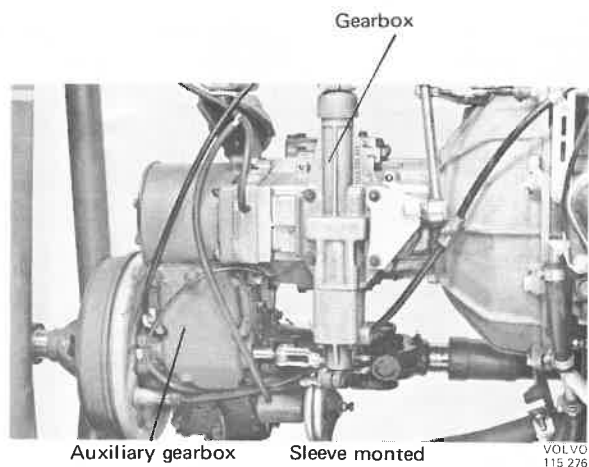


Fig. 43-21b. Gearbox in vehicle

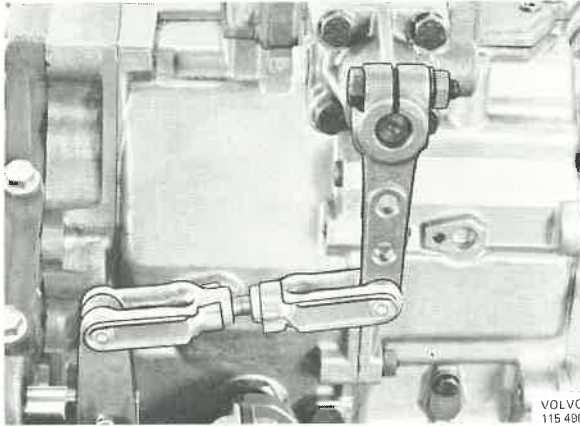


Fig. 43-22. Link

4. Remove the parking brake wire from the lever. Remove the clamp securing the wire to the engine.
5. Disconnect the cable to the sender on the cover. Remove the link arm from the lever on the auxiliary gearbox, see Fig. 43-22.
6. Remove the screws for the cover. Pull the wire out of the guide sleeve on the propeller shaft brake and lift up the cover.

#### Installing the cover

1. Clean the contact surface on the cover and the auxiliary gearbox. Coat the surface of the auxiliary gearbox with sealing agent.

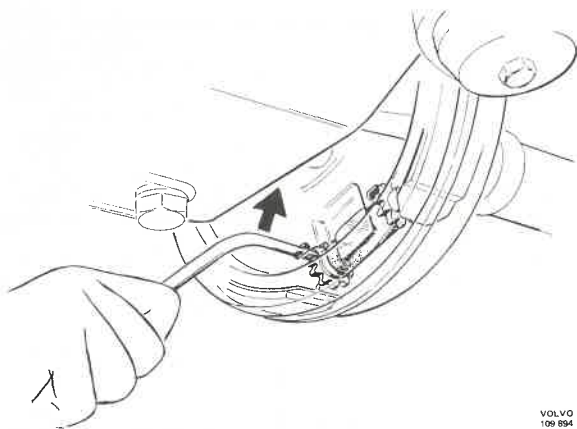


Fig. 43-23. Adjusting brake shoes

2. Hold the wire out of the way and fit the cover in position. Tighten up the screws.
3. Fit the link arm and connect up the cable to the sender.
4. Fix the wire to the lever. Clamp the wire to the engine with the clamp. Tighten the nut so that full braking is obtained at the 4th-5th ratchet with the **propeller shaft brake properly adjusted**. If necessary, adjust the parking brake according to points 6 and 7.
5. Place the floor plate in position and screw tight the bolts. Fit the engine casing.
6. Adjust out one of the brake shoes with a screwdriver (Fig. 43-23) until it is just possible to rotate the drum with the rear end jacked up. Slacken the adjuster screw until the drum rotates freely, but maximum five teeth. Adjust the other brake shoe in the same way.
7. Check the function of the control lever. If the parking brake does not give full braking at 4th-5th ratchet, in spite of the fact that the propeller shaft brake is properly adjusted, alter the length of the wire with the nut at the front end.

#### Replacing the control mechanism

##### Removing

1. Remove the casing from the engine. Remove the bolts securing the floor plate. Remove the plate. Drain the oil from the auxiliary gearbox.

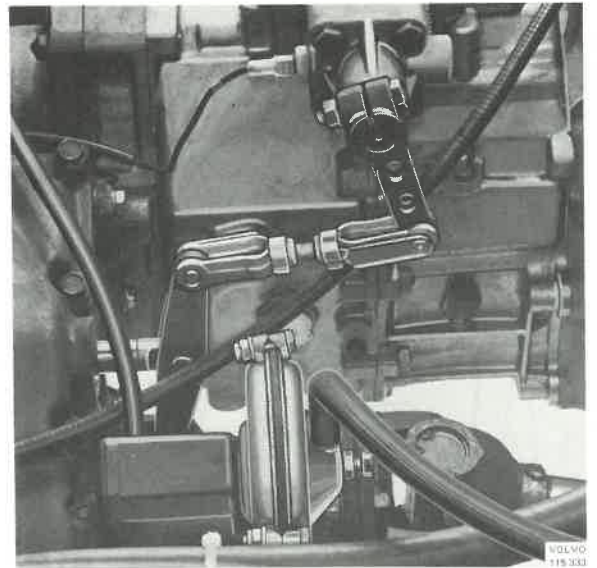


Fig. 43-24. Control mechanism

VOLVO  
115 272

Fig. 43-25. Removing cover

2. Remove the bolts securing the propeller shaft and remove the shaft.
3. Disconnect the hose to the control cylinder, see Fig. 43-24. Remove the evacuation hose to the control mechanism housing.
4. Remove the bolts securing the control mechanism housing to the auxiliary gearbox.

### Installing

1. Clean the contact surface on the auxiliary gearbox.

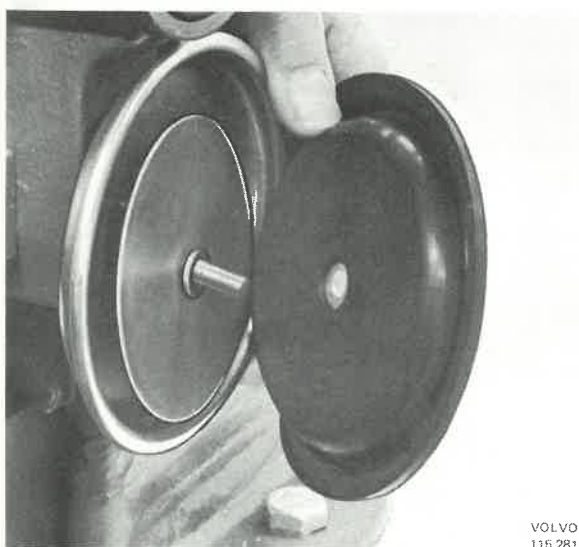
VOLVO  
115 281

Fig. 43-26. Remove diaphragm

2. Coat the control mechanism contact surface with sealing agent and secure the mechanism to the auxiliary gearbox.
3. Remove the cover on the control cylinder and the spring, see Fig. 43-25.
4. Remove the nut on the pull rod. Remove the diaphragm and the washers, see Fig. 43-26. Take care of the washer in the centre of the diaphragm.
5. Pull the pull rod and check that the flange is in full mesh with the output shaft. Screw in the nut on the pull rod so that it is on the inside of the holed nut. Fit the inner washer for the diaphragm on the rod. Press the washer against the holed nut. When the pull rod is pulled back and forth there should be a clearance of 0.1 mm (0.0039"). If necessary, adjust until the correct clearance is obtained, see Fig. 43-27.
6. Fit the diaphragm and place the spacer washer in the centre of the diaphragm, see Fig. 43-26. Fit the outer washer and lock nut. Hold the diaphragm and washer when tightening up the nut.
7. Fit the thrust spring, see Fig. 43-25, and the cover, see Fig. 43-28. Screw the bolt to the bottom. Screw out the bolt 53/10 tours (8 mm = 5/16"). Tighten up the lock nut.

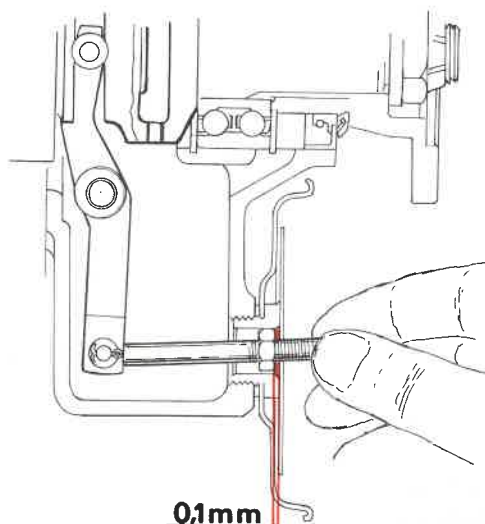
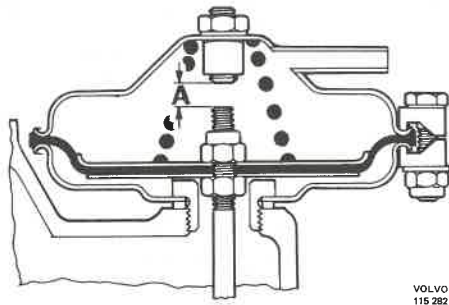
**0.1mm**VOLVO  
115 280

Fig. 43-27. Adjusting clearance

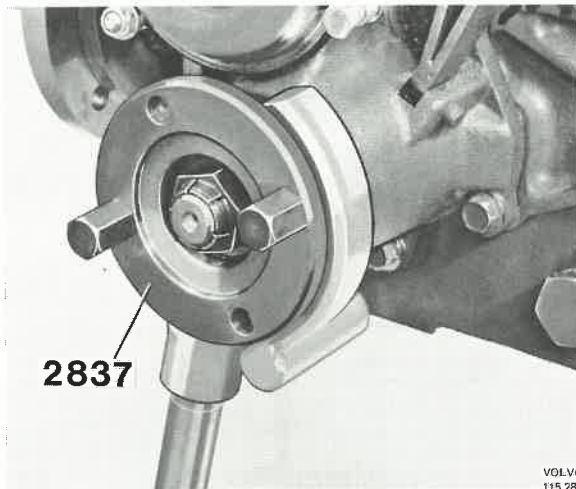


VOLVO  
115 282

A = 5 3/10 turns (8 mm)

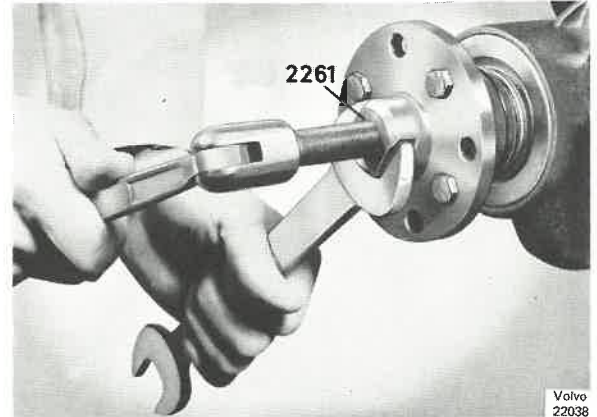
Fig. 43-28. Adjusting screw

8. Fit the propeller shaft and tighten up the bolts to a torque of 55-65 Nm (5.5-6.5 kpm = 40-47 lbftf).
  9. Fit and tighten up the evacuation and vacuum hoses.
- Fill the auxiliary gearbox with oil. Concerning quantity and type, see under "Data".
10. Place the floor plate in position and screw it tight. Fit the engine casing.



VOLVO  
115 283

Fig. 43-29. Fitting counterhold



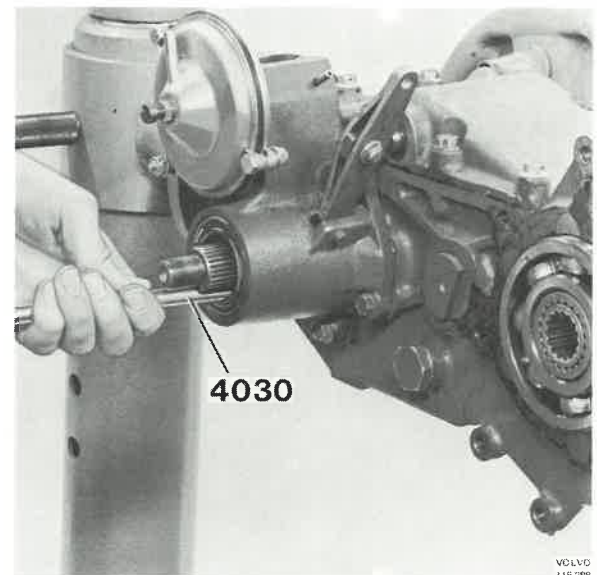
Volvo  
22038

Fig. 43-30. Removing flange

### Replacing flange seal for control mechanism and output shaft

Special tools: 1845, 2261, 2806, 2837, 4030.

1. Remove the propeller shaft from the flange.
2. Fit counterhold 2837, see Fig. 43-29, on the flange (applies only to the control mechanism). Unscrew the nut.
3. Fit not puller 2261, see Fig. 43-30, and pull off the flange.
4. Pull out the seal with 4030, see Fig. 43-31.
5. Fill the space between the sealing lips and their reverse sides with grease, see Fig. 43-32.



VOLVO  
115 286

Fig. 43-31. Removing seal

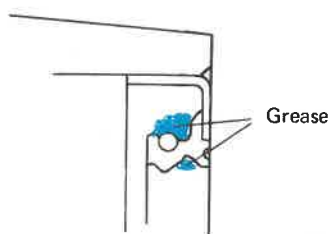


Fig. 43-32 Placing grease

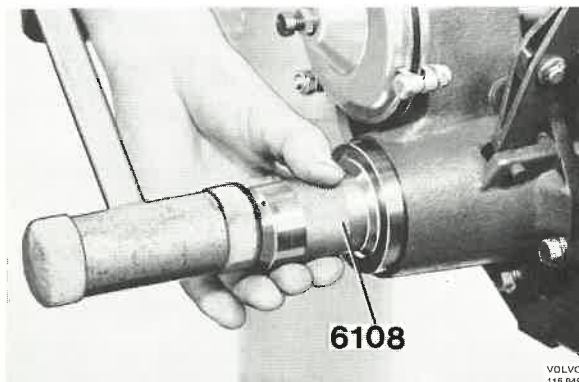


Fig. 43-33. Driving seal

6. Drive the seal into the housing with 2806, see Fig. 43-33.

Fit a new seal on the flange, see Fig. 43-34.

7. Pull on the flange with 1845, see Fig. 43-35. Remove the tool and fit 2837. Fit the nut and tighten it to a torque of 280-300 Nm (28-30 kpm = 202-217 lbftf).



Fig. 43-34. Flange seal

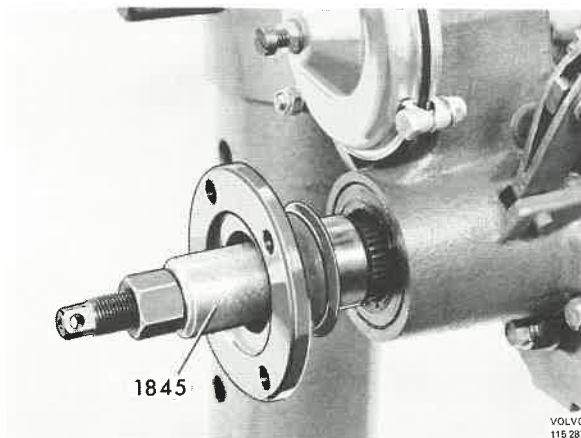


Fig. 43-35. Pressing flange

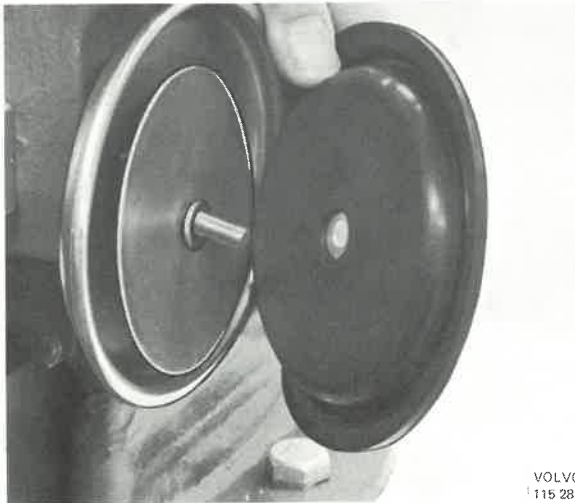
8. Fit and tighten up the propeller shaft. Tighten the bolts to a torque of 55-65 Nm (5.5-6.5 kpm = 40-47 lbftf).

#### Replacing the diaphragm in control cylinder

1. Remove the casing over the engine. Remove the bolts securing the floor plate. Remove the plate.
2. Remove the bolts securing the cover. Remove the cover and the spring, see Fig. 43-36.
3. Remove the nut on the pull rod. Hold the thrust washer and diaphragm securely so that they do not twist. Remove the thrust washer and dia-



Fig. 43-36. Removign cover



VOLVO  
115 281

Fig. 43-37. Removing diaphragm

phragm and take care of the washer in the centre of the diaphragm, see Fig. 43-37.

4. Fit the new diaphragm. Place the washer in the centre of the diaphragm and also the thrust washer.
5. Tighten up the nut. Hold the thrust washer and diaphragm securely so that they do not twist when the nut is tightened up.
6. Fit the spring with the larger contact surface facing the thrust washer. Fit the cover. Space the bolts evenly round the cover and tighten up.
7. Place the floor plate in position and bolt it tight. Fit the engine casing.

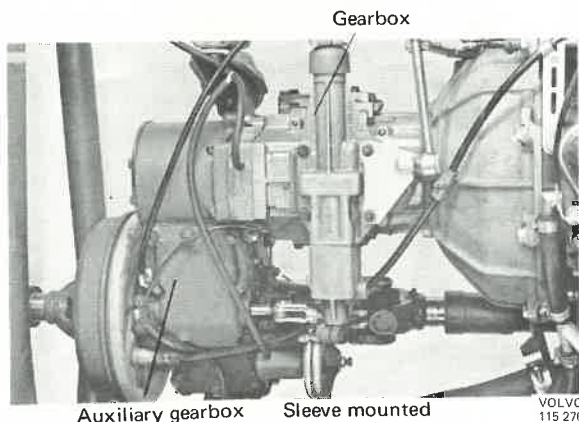
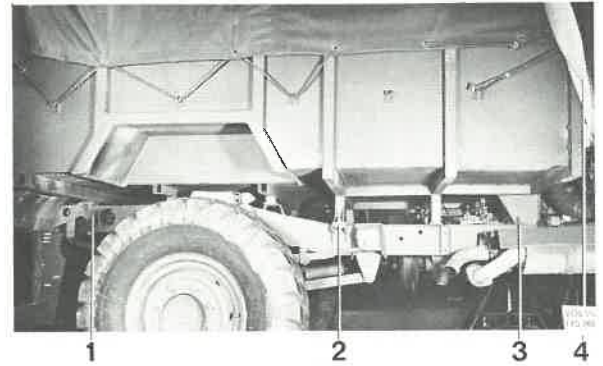


Fig. 43-38. Gearbox in vehicle



- |            |                 |
|------------|-----------------|
| 1. Bolting | 3. U-bolts      |
| 2. Bolting | 4. Hoist straps |

Fig. 43-39. Removing the platform

## GEARBOX

### Removing the gearbox

Special tool: 6128, 6129, 6136, 6137.

1. Drain the oil from the gearbox.
2. Release the parking brake.
3. If the gearbox is to be removed with a block and tackle and the vehicle has a platform superstructure, the platform must be removed. The platform can be removed after the bolts and the U-bolts, Fig. 43-39 have been removed. Lift off the platform with a hoist which is fixed to the lifting eyelets, see Fig.

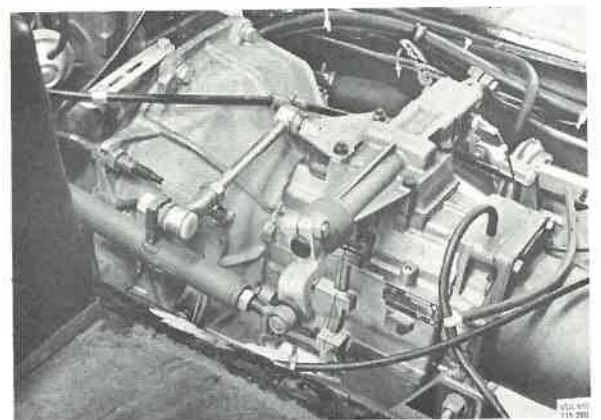


Fig. 43-40. Gear shift with cross stay

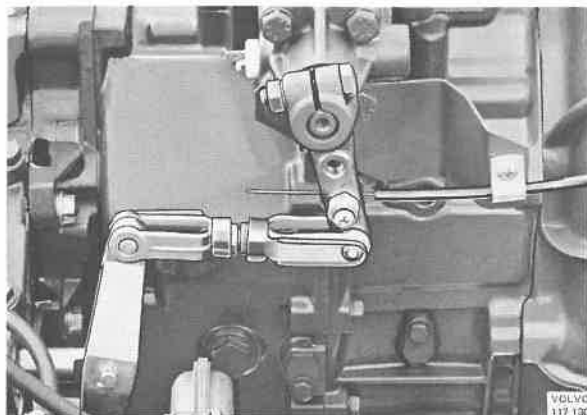


Fig. 43-41. Wire for shift indicator

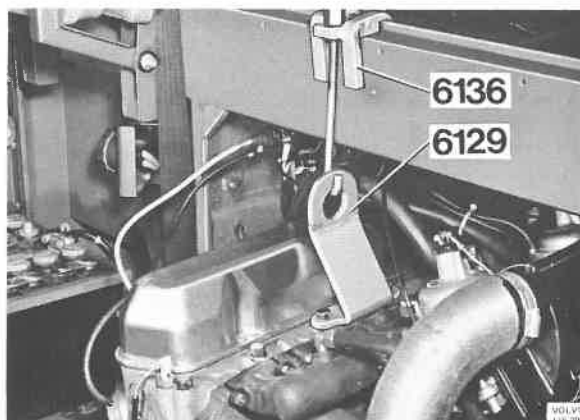


Fig. 43-43. Attaching hoist eyelet

4. Remove the cover over the battery. Disconnect the battery negative cable.
5. Remove the cross stay, Fig. 43-40, to the gear shift bar and remove the bar from the gearbox lever.
6. Remove the wire for the shift indicator, see Fig. 43-41, from the outer shift axle housing.
7. Remove the retainer which holds the fork to the disengaging lever. Remove the rear nut for the disengaging wire. Remove the wire.
8. Remove the exhaust manifold.
9. Remove the hose to the auxiliary gearbox control mechanism.
10. Remove the cables to the sender on the gearbox and auxiliary gearbox.
11. Remove the evacuation hoses to the clutch casing, gearbox and auxiliary gearbox control mechanism.
12. Unscrew the speedometer wire with 6128, Fig. 43-42. Fix the hoist hooks 6129 to the two rear cylinder head bolts, Fig. 43-43 and fit lifting tool 6136.
13. Remove the front and rear propeller shafts from the auxiliary gearbox. Remove the rear axle from the rear differential carrier.
14. Remove the rear exhaust pipe attachment to the body. Remove the bolts on the flange at the silencer. Remove the silencer from the body.
15. Remove the drum from the propeller shaft brake. Remove the brake shoes and disconnect the wire from the lever.

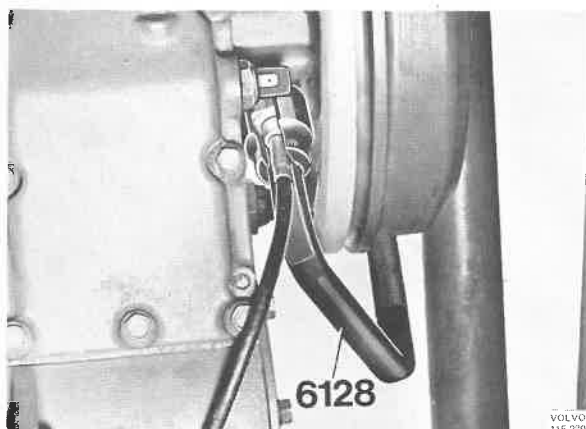


Fig. 43-42. Removing speedometer wire

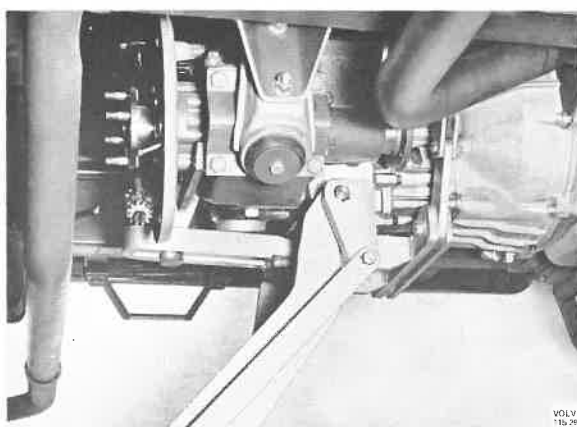


Fig. 43-44. Jack under gearbox

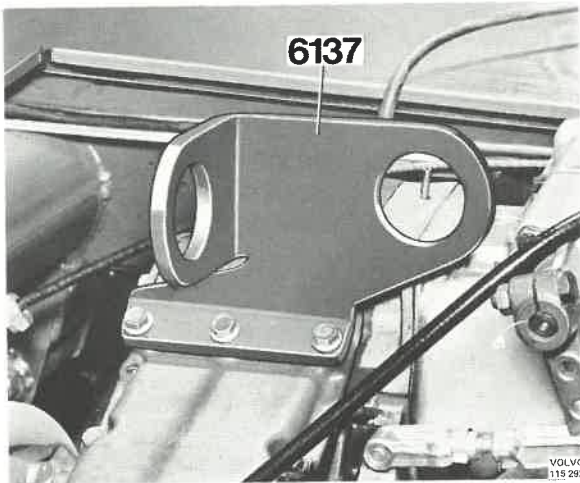


Fig. 43-45. Attaching haist

- 16 Place a jack under the gearbox, Fig. 43-44. Remove the bolts securing the rear engine mounts to the frame. When removing the gearbox with a block and tackle, use tool 6137, see Fig. 43-45.
- 17 Lower the gearbox so that the engine hangs by the bracket on the engine. Remove the lower bolts round the clutch casing. Remove the bolt for the starter motor. Remove the screw securing the earth terminal (pleat) to the casing.
- 18 Remove the remaining bolts round the clutch casing. Remove the bolt for the starter motor and lift off the starter motor.
- 19 Pull the gearbox backwards. Observe due care that the clutch casing surface against the engine is not damaged since the sealing between engine and clutch casing must be in very good condition. For this reason do not use an iron jemmy or similar for this purpose. Lower the jack and pull forward the gearbox.

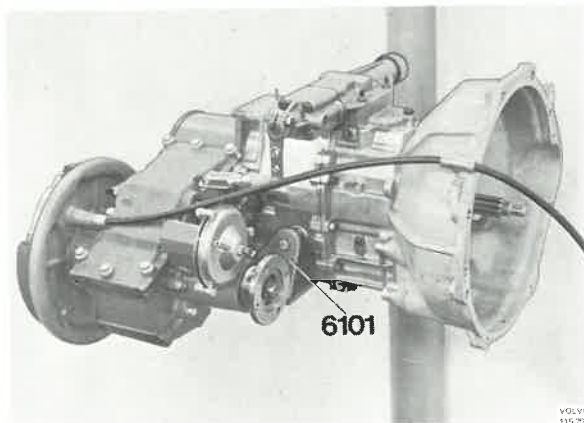


Fig. 43-46. Fixing gearbox on stand

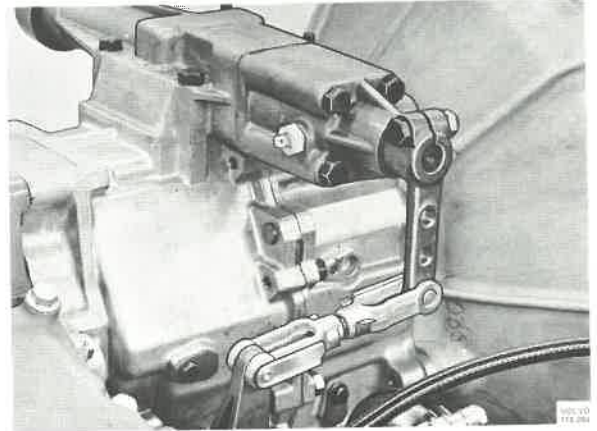


Fig. 43-47. Link between gearbox and aux. gearbox

### Disassembling the gearbox

Special tools: 1784, 1801, 1817, 2014, 2116, 4090, 6100, 6101.

1. Clean the outside of the gearbox and auxiliary gearbox.
2. Remove the cover on the left-hand side of the gearbox and the gearbox filler plug. Fit fixture 6101 on the gearbox, see Fig. 43-49. Secure the gearbox on a reconditioning stand, see Fig. 43-46.
3. Remove the link arm between the gearbox and auxiliary gearbox, Fig. 43-47.
4. Remove the rear cover on the auxiliary gearbox and the nuts securing the box. Fit puller 2116, Fig. 43-48, and pull the auxiliary gearbox from the gearbox.
5. Remove the lever on the shift axle and remove the cover. Remove the outer part of the selector shaft housing.

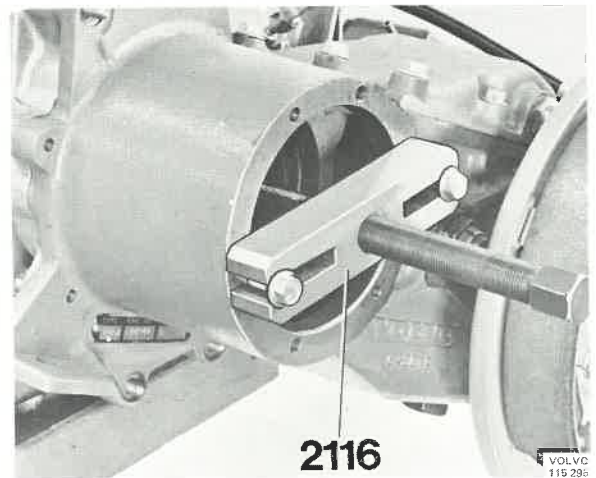


Fig. 43-48. Attaching puller

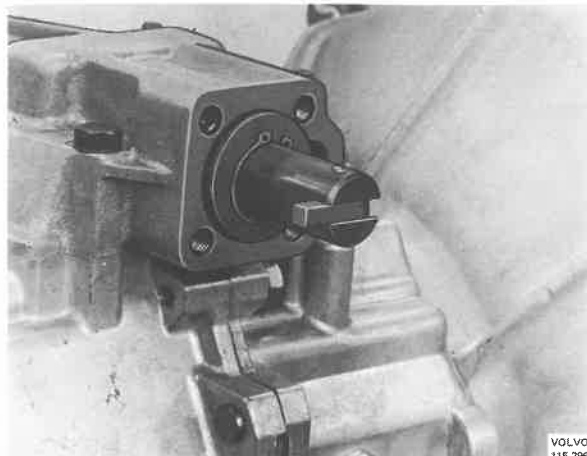


Fig. 43-49. Tube pin in selector shaft

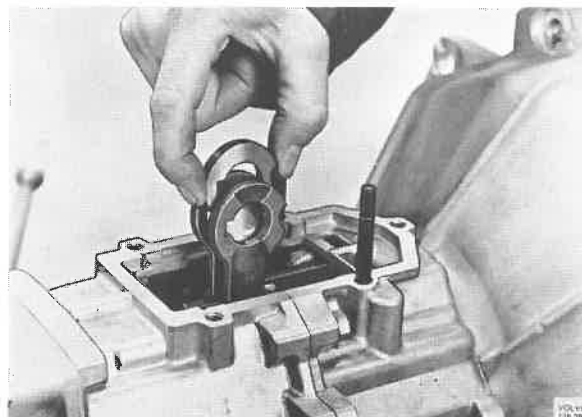


Fig. 43-51. Removing gear shift bar

6. Remove the tubular pin from the selector shaft, Fig. 43-49 and remove the lug. Remove the circlip holding the selector fork.
7. Remove the circlip, washer, spring, spacer tube, washer, spring and spacer tube.
8. Pull out the selector shaft and remove the lock shaft, Fig. 43-50.
9. Remove the bolts and nuts securing the selector shaft housing. Remove the housing.
10. Remove the intermediate gear shift bar, Fig. 43-51. Remove the packing.
11. Engage two gears. Remove the nut on the output shaft, Fig. 43-52, and pull off the sleeve. Remove the nuts for the rear cover and take care of the washers.
12. Remove the cover, shims and packing, Fig. 43-53.

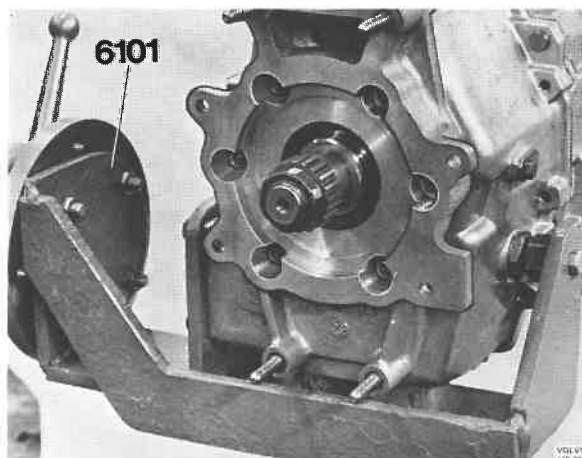


Fig. 43-52. Output shaft nut

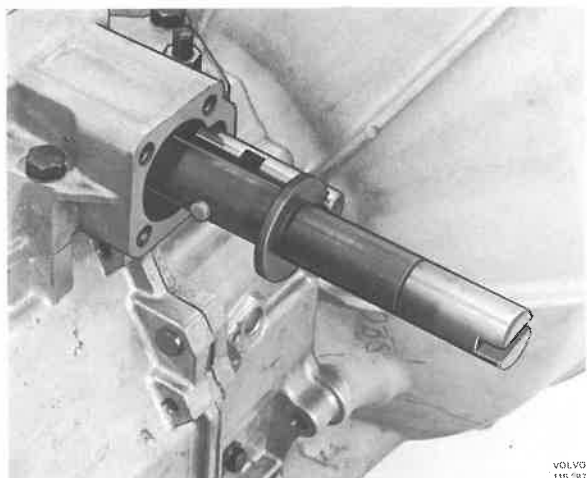


Fig. 43-50. Selector shaft with lock shaft

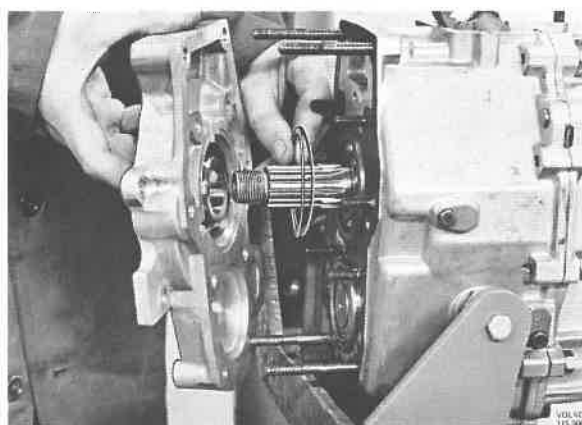


Fig. 43-53. Removing rear cover and shim

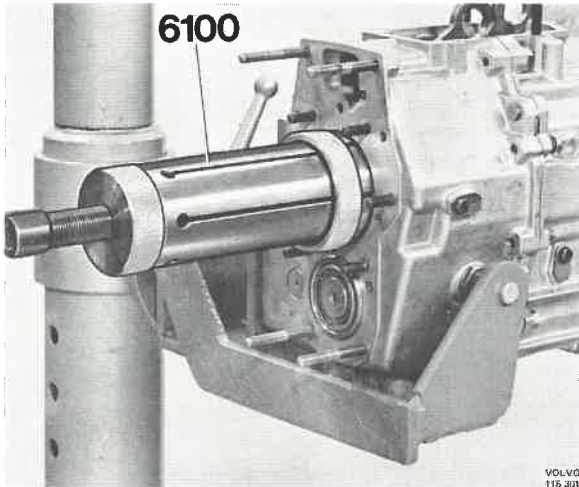


Fig. 43-54. Removing rear bearing

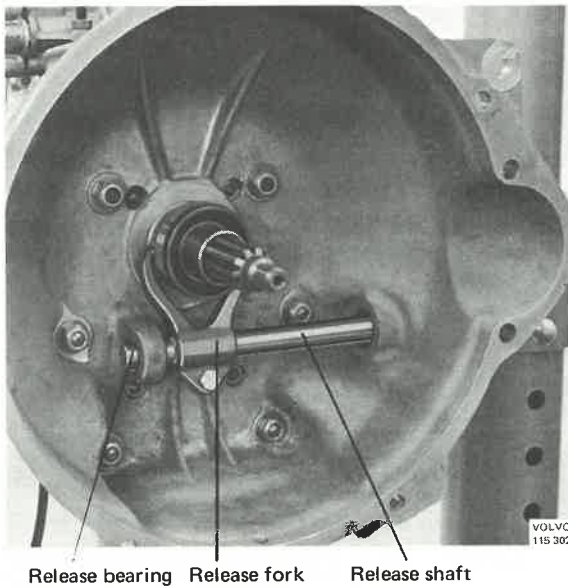


Fig. 43-55. Throw-out shaft and bearing

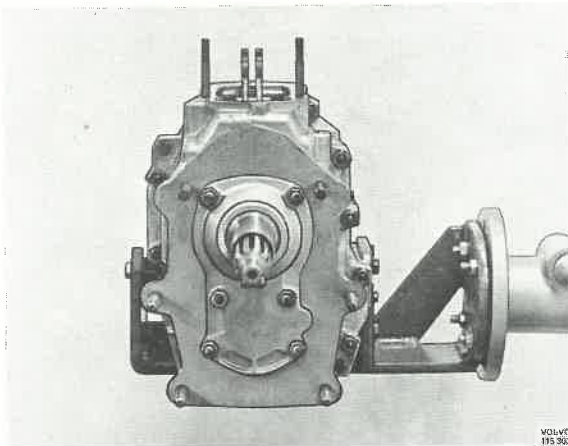


Fig. 43-56. Front cover

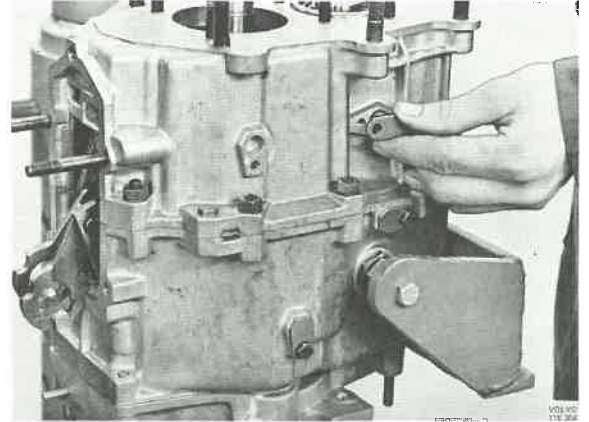


Fig. 43-57. Removing bearing pins

13. Remove the circlip for the output shaft bearing. Remove the shims behind the circlip. Remove the bearing with 6100, Fig. 43-54. Turn the gearbox.
14. Remove the disengaging bearing, lever and disengaging shaft, Fig. 43-55. Remove the nuts securing the clutch casing. Remove the casing.
15. Remove the front cover, Fig. 43-56. Remove the shims for the input shaft and intermediate shaft.
16. Remove the packing. Remove the circlip on the input shaft. Remove the shims behind the circlip. Remove the circlip on the input shaft bearing. Remove the bearing with 6100.
17. Turn the gearbox. Remove the bearing journals for the selector forks, Fig. 42-47.
18. Knock out both the guide pins holding together the gearbox housing halves, Fig. 43-58. Remove the nuts and the Allen bolts (6 mm = 1/4").

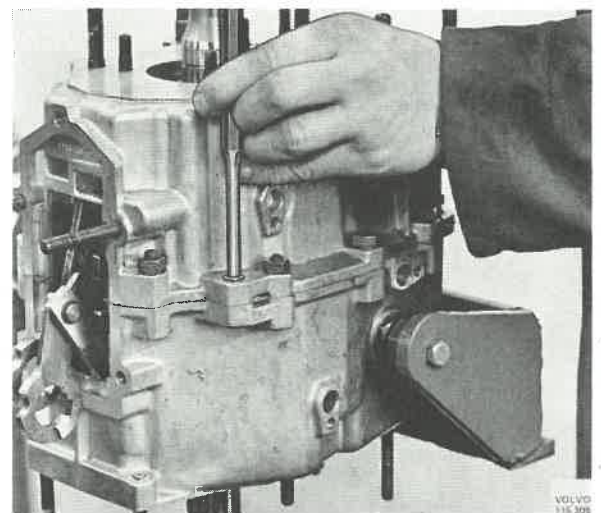


Fig. 43-58. Driving out guide pin

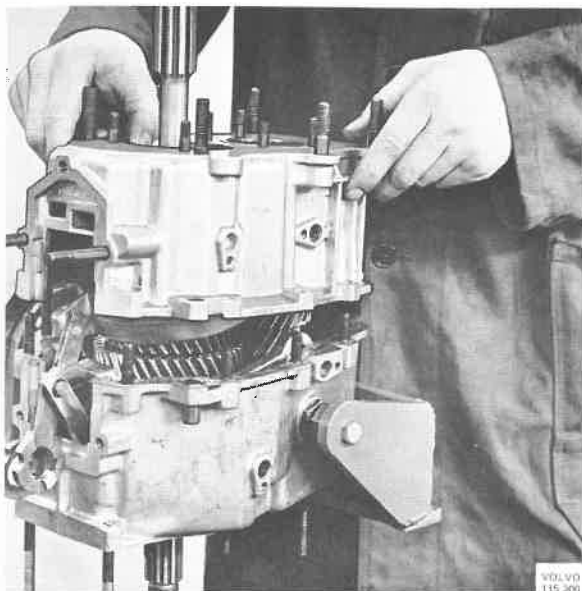


Fig. 43-59. Removing housing half

19. Remove the front housing half, Fig. 43-59. Remove the lock pin and spring for 3rd-4th synchronizing.
20. Remove the input shaft, the synchronizing cone and roller bearing, Fig. 43-60.
21. Remove the engaging sleeve and selector fork for 3rd-4th synchronizing, Fig. 43-61. Remove the interlock units.
22. Lift up the output shaft and remove the selector fork for 1st-2nd synchronizing, Fig. 43-62.
23. Lift the output shaft to the one side and remove the intermediate shaft, Fig. 43-63.

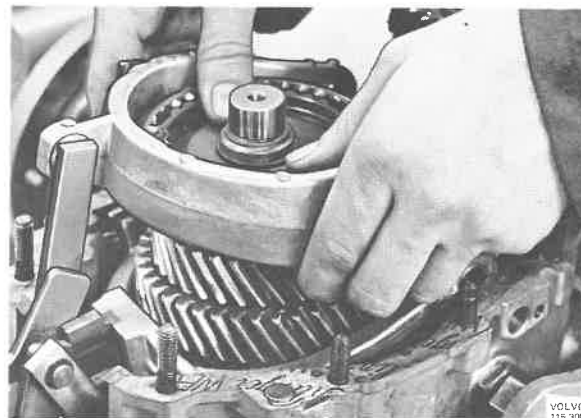


Fig. 43-61. Removing engaging sleeve

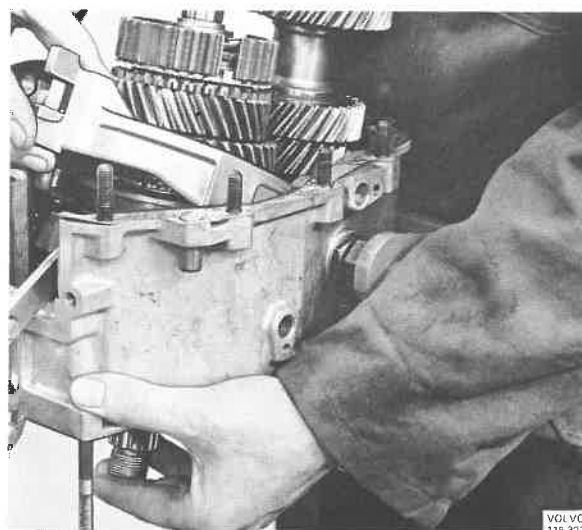


Fig. 43-62. Removing selector fork

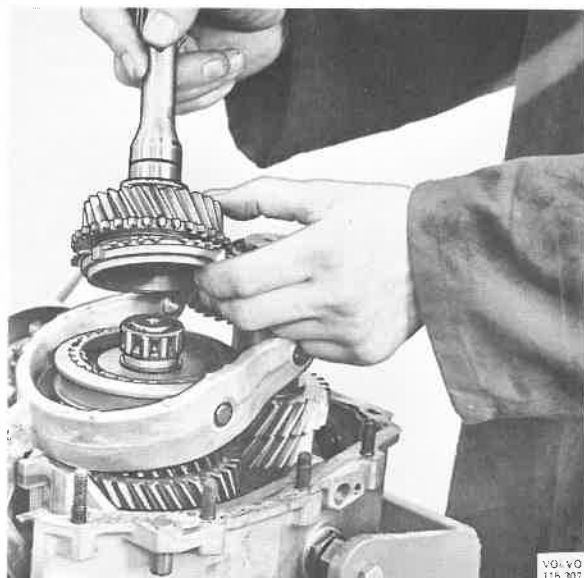


Fig. 43-60. Removing input shaft

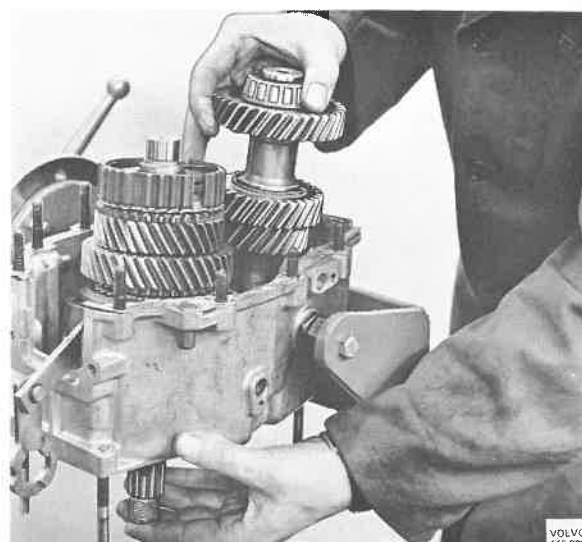


Fig. 43-63. Removing intermediate shaft

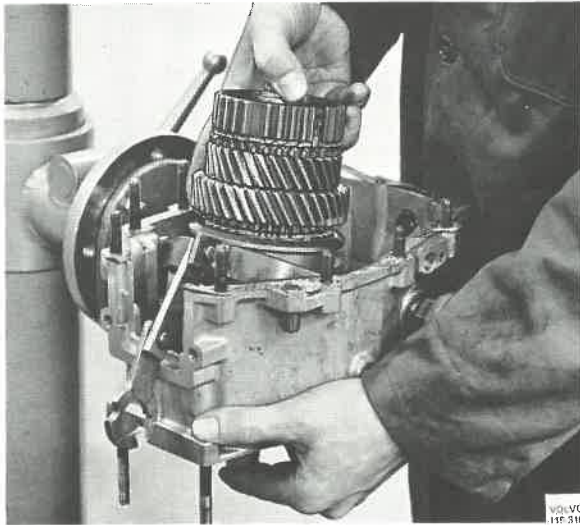


Fig. 43-64. Removing output shaft

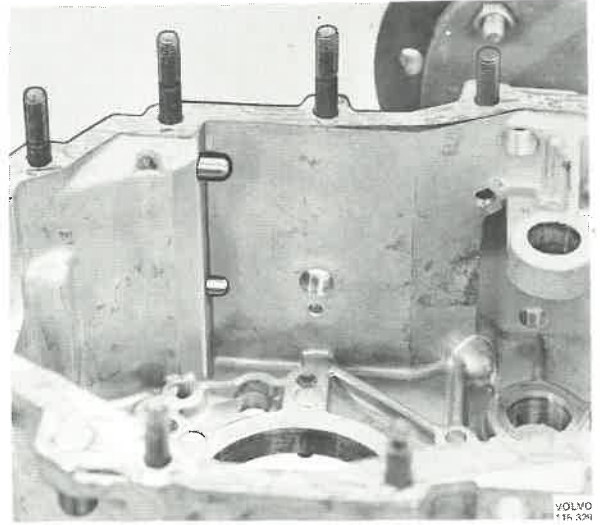


Fig. 43-67. Lock pin

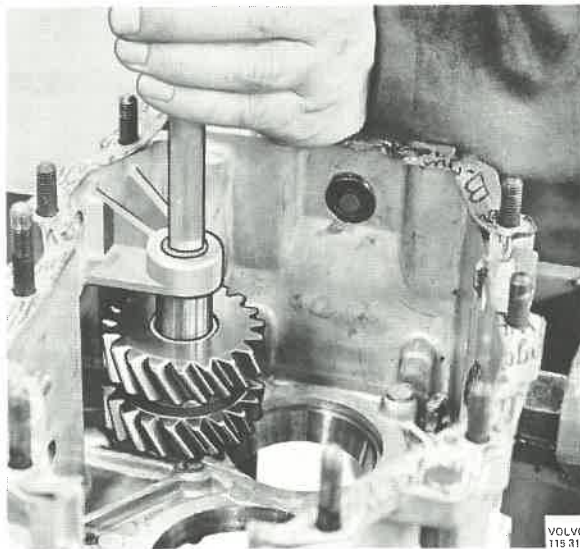


Fig. 43-65. Driving out reverse gear shaft

24. Remove the output shaft and the selector fork for the reverse shaft, Fig. 43-64.
25. Drive out backwards the shaft for the reverse gear, Fig. 43-65, and remove the gear.
26. Drive out the outer races for the intermediate shaft bearing with 2014 + 1801, Fig. 43-66.
27. Remove the lock pins and the springs, Fig. 43-67, for the selector forks. Remove the housing half from the fixture.

*Disassembling the output shaft*

1. Place the shaft in a press with a counterhold under 1st gear, Fig. 43-68. Press off the inner race, the reverse gear and 1st gear. Remove the needle bearing.

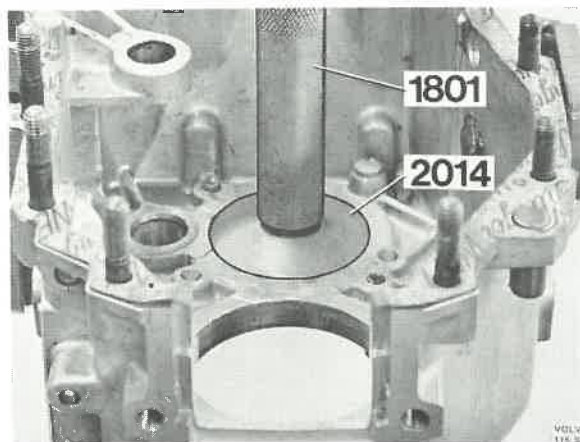


Fig. 43-66. Driving out outer race

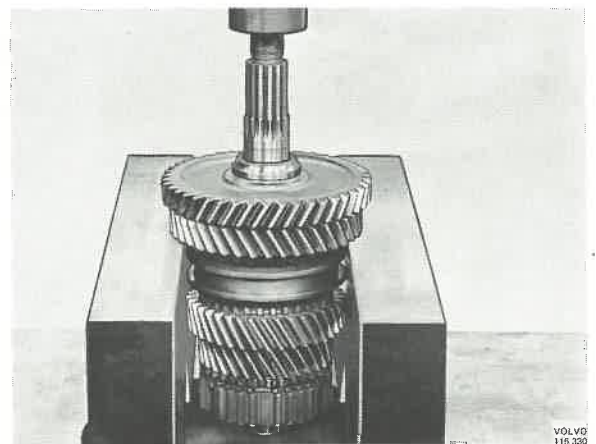


Fig. 43-68. Removing 1st gear



Fig. 43-69. Removing circlip

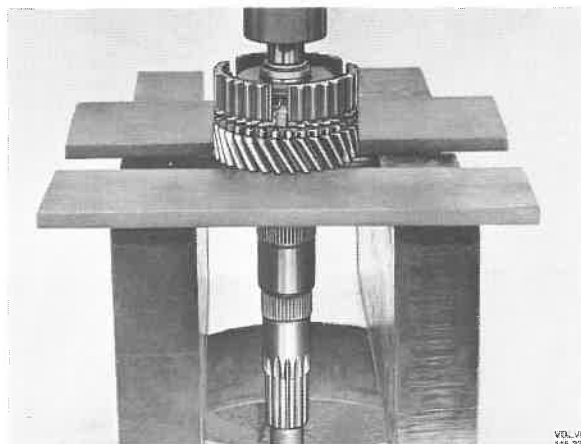


Fig. 43-71. Removing hub and gear

2. Remove the lock ring for 1st-2nd synchronizing hub, Fig. 43-69. Place the shaft in a press with a counterhold under 2nd gear, Fig. 43-70. Press off the synchronizing hub and gear. Remove the engaging sleeve and the interlock units. Remove the needle bearing.
3. Remove the lock ring for 3rd-4th synchronizing hub. Place the shaft in a press with a counterhold under 4th gear, Fig. 42-71. Press of the synchronizing hub and gear. Remove the needle bearing.

#### *Disassembling the countershaft*

1. Remove the circlip for the front bearing. Press off the cluster gear and the front roller bearing, Fig. 43-72.
2. Remove the circlip for 3rd gear and press of the gear, Fig. 43-73.
3. Press off the rear roller bearing, Fig. 43-74.

Make sure that the counterhold lies against the bearing when removing.

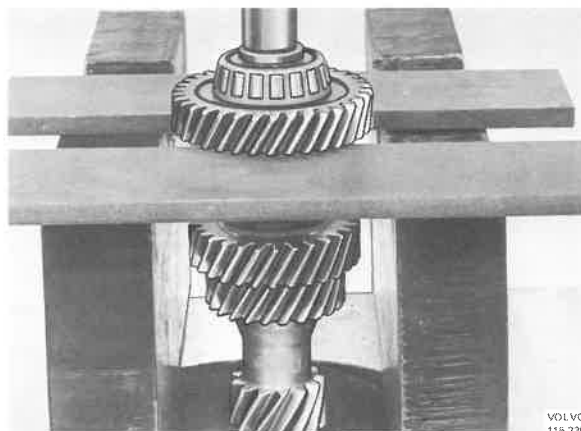


Fig. 43-72. Removing cluster gear

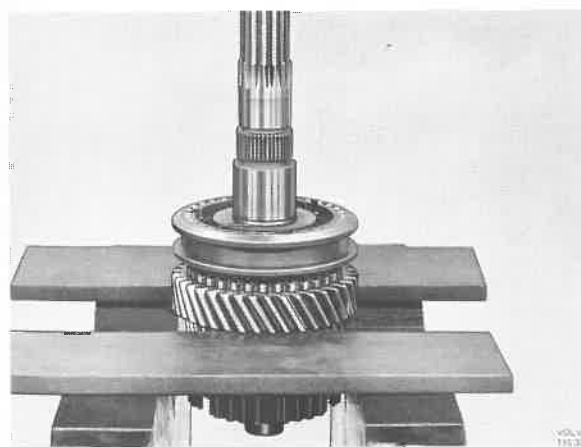


Fig. 43-70. Removing hub and gear

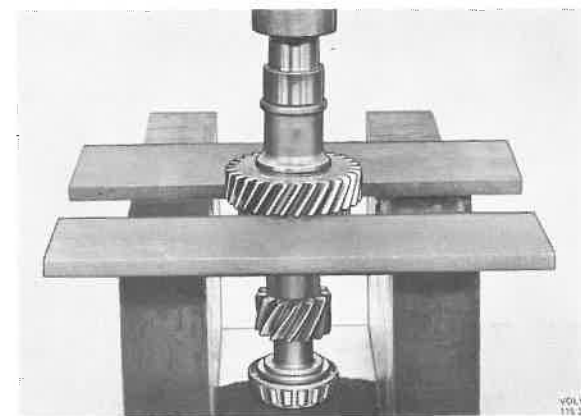


Fig. 43-73. Removing 3rd gear

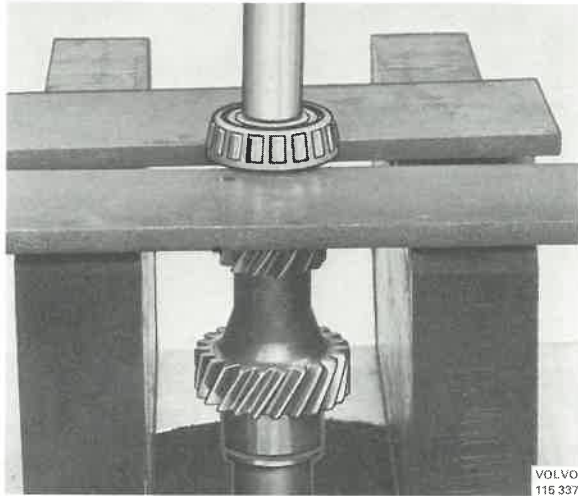
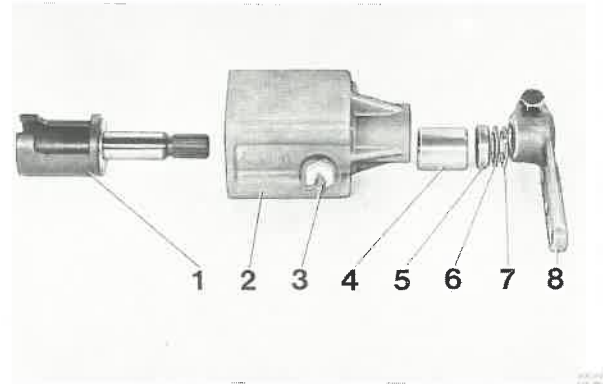
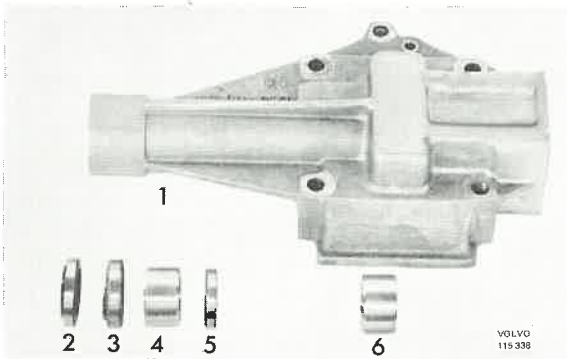


Fig. 43-74. Removing bearing



- |                  |            |
|------------------|------------|
| 1. Selector fork | 5. Seal    |
| 2. Housing       | 6. Washer  |
| 3. Contact       | 7. Circlip |
| 4. Bushing       | 8. Lever   |

Fig. 43-77. Outer selector shaft housing



- |            |            |
|------------|------------|
| 1. Housing | 4. Bushing |
| 2. Seal    | 5. Seal    |
| 3. Seal    | 6. Bushing |

Fig. 43-75. Removing seal and bushing

*Disassembling the selector shaft housing*

1. Fit the housing in a vice. Pull out the seal, bushing and seals, Fig. 43-75 with 1817, Fig. 43-76.

2. Pull out the bushing with 1817.

*Disassembling the outer selector shaft housing*

1. Remove the screw on the lever. Remove the lever (8, Fig. 43-74). Remove the reverse light contact.
2. Remove the selector fork from the housing.
3. Knock out the bushing 4 and seal 5 with 4090, Fig. 43-78.

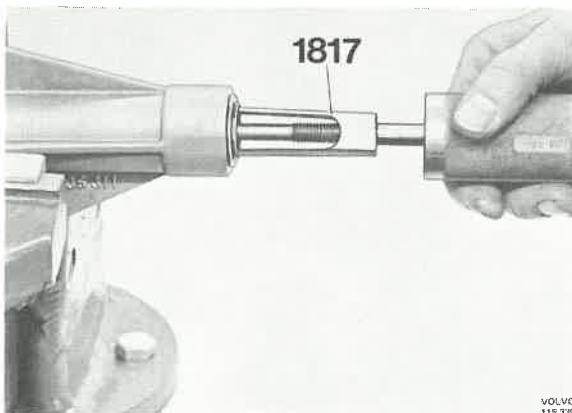


Fig. 43-76. Gear selector housing

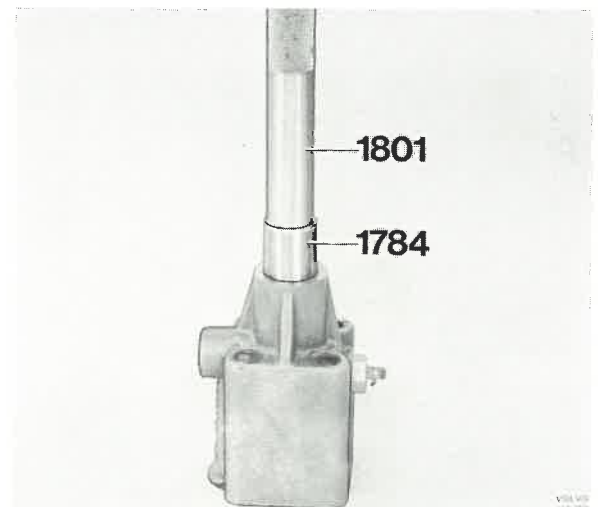


Fig. 43-78. Driving out bushing and seal

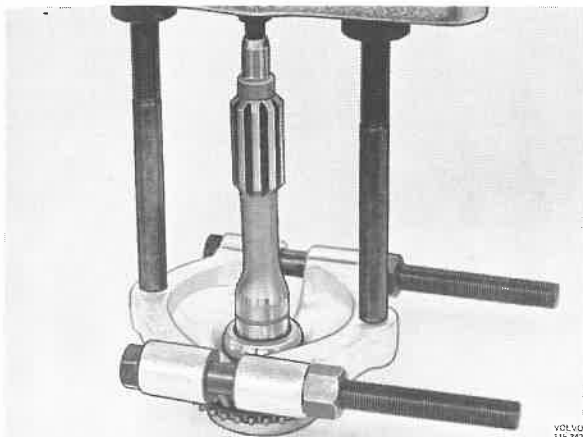


Fig. 43-79. Removing inner race

### Checking and replacing parts

Clean all parts and check for wear and damage. All damaged or worn parts should be replaced. Sealing rings, O-rings and packings should always be replaced. When replacing sealing rings, make sure that the surfaces which provide the sealing are carefully checked. If the surfaces are scored or damaged in any other way, the sealing must be replaced.

In order to be able to adjust the clearance in the gearbox, the inner bearing race on the input shaft must be pulled off with a standard puller, see Fig. 43-79.

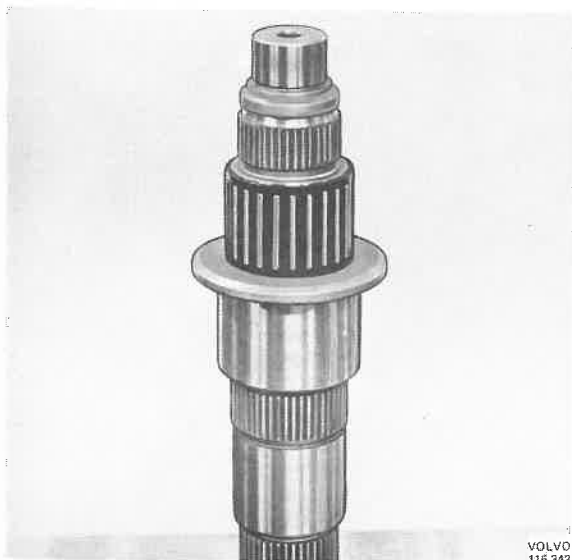


Fig. 43-80. Needle bearing for 3rd gear



Fig. 43-81. Installing synchronizing hub

### Assembling the gearbox

Special tools: 1784, 1801, 2022, 2395, 2564, 6011, 6012, 6024, 6101, 6102, 6103, 6104.

#### Output shaft

1. Oil the needle bearing for 3rd gear and place it on the shaft, Fig. 43-80.
2. Fit 3rd gear and the synchronizing cone. Place the spring on the interlock bodies in the synchronizing hub. Fit the hub, Fig. 43-81.
3. Press on the hub with 2022, Fig. 43-82. Check that the cone lugs enter the hub. Fit the lock ring which gives minimum clearance. Lock rings are available in sizes 1.8, 1.9 and 2.0 mm (0.072, 0.076 and 0.079").

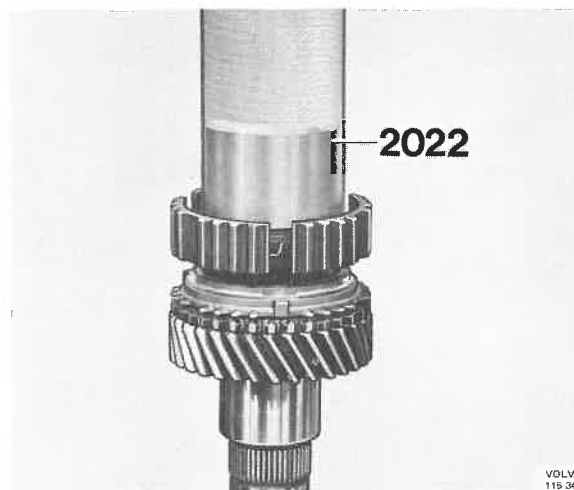


Fig. 43-82. Pressing on hub

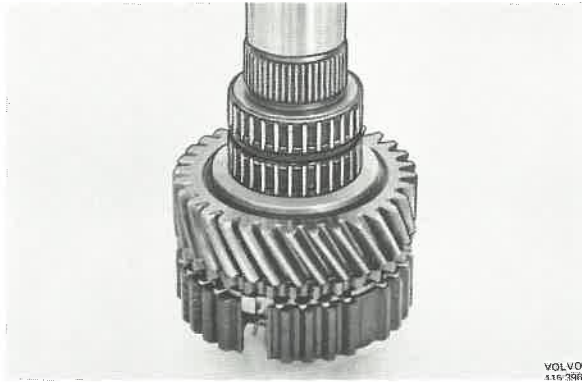


Fig. 43-83. Needle bearing

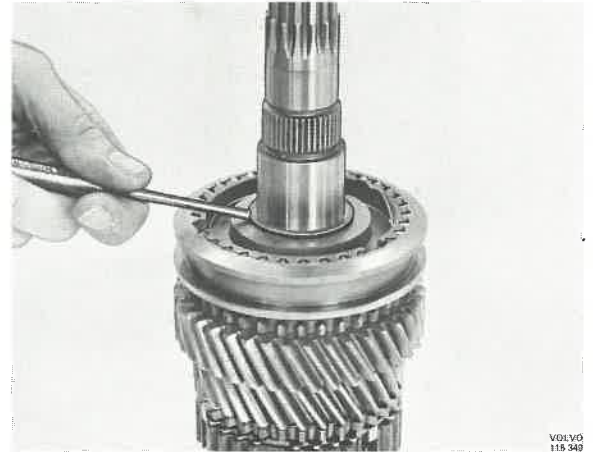


Fig. 43-86. Driving on lockring

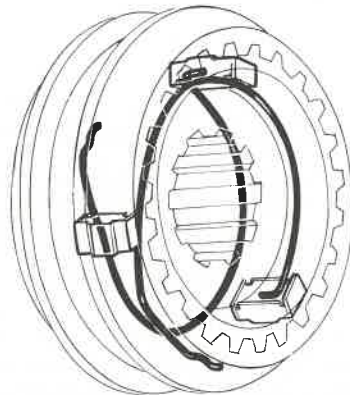


Fig. 43-84. Placing spring

4. Fit the needle bearings for 2nd gear, Fig. 43-83. Fit 2nd gear and the synchronizing cone.
5. Assemble the synchro unit for 1st-2nd gears. The springs for the interlock units are placed as shown in Fig. 43-84, starting off with different interlock units.
6. Fit the hub. Place the shaft on 6024, Fig. 43-85, and press on the hub.
7. Fit the lock ring which gives minimum clearance. Lock rings are available in sizes 1.8, 1.9 and 1.0 mm (0.072, 0.076 and 0.079"). Check that the lock ring has bottomed properly by driving it down with a drift, Fig. 43-86.

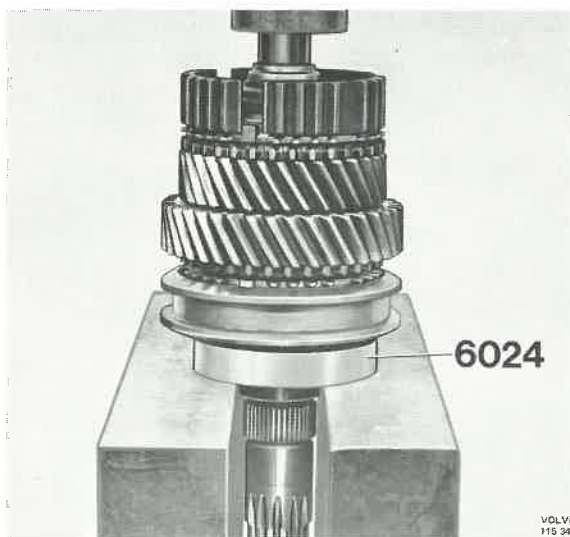


Fig. 43-85. Pressing on hub



Fig. 43-87. Installing reverse gear

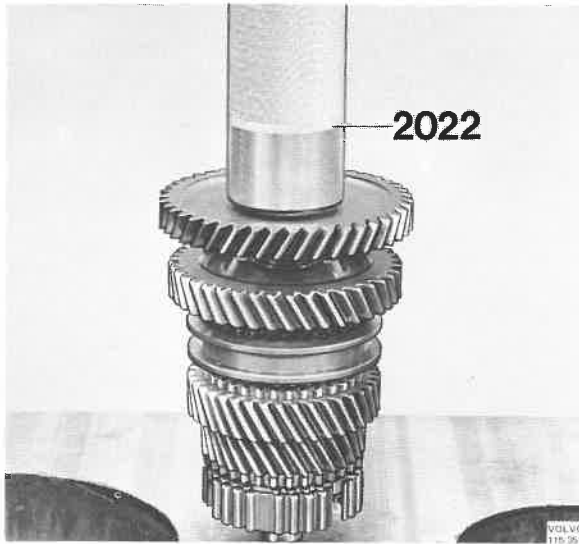


Fig. 43-88. Pressing on gear

8. Oil the needle bearing for 1st gear and fit it. Fit the synchronizing cone and 1st gear. Place the gear for reverse in position, but turn it as shown in Fig. 43-87 with the larger hub section facing 1st gear. Press it on with 2022, Fig. 43-88.
9. Fit the inner race for the rear ball bearing. Press it on with 2395, Fig. 43-89.

#### Countershaft

1. Place 3rd gear on the shaft with the bevelled edge of the gear facing downwards, see Fig. 42-90. Press on the gear with 2022, Fig. 43-91. Fit the lock ring.
2. Fit the cluster gear with the larger part of the hub facing downwards, Fig. 43-92. Press on the gear with 2022.

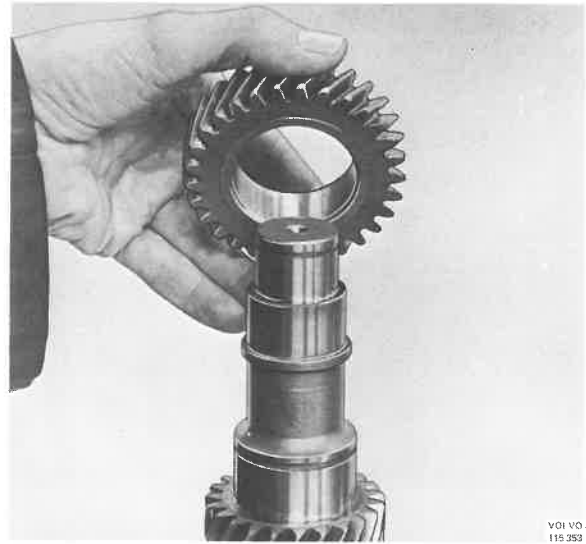


Fig. 43-90. Placing 3rd gear

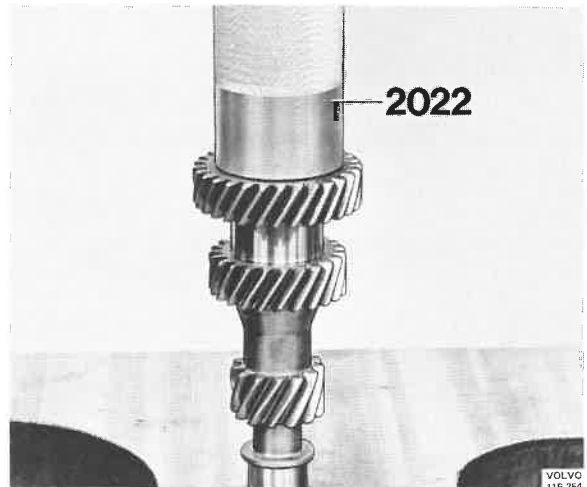


Fig. 43-91. Pressing on gear

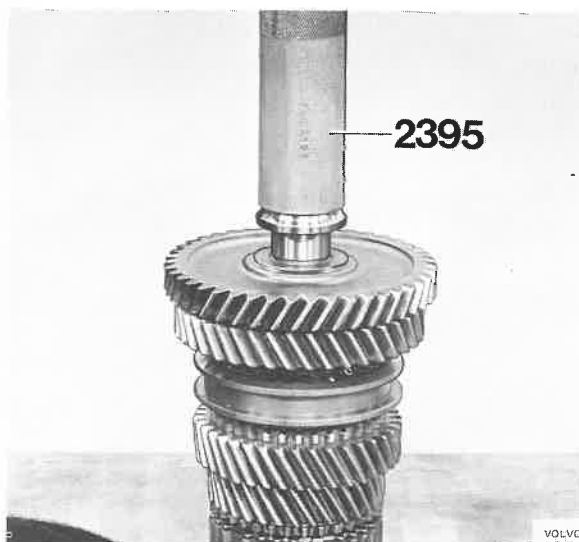


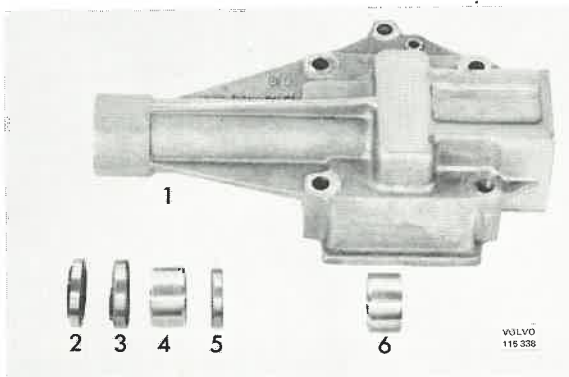
Fig. 43-89. Pressing on inner race



Fig. 43-92. Placing gear



Fig. 43-93. Pressing on bearing



- |            |            |
|------------|------------|
| 1. Housing | 4. Bushing |
| 2. Seal    | 5. Seal    |
| 3. Seal    | 6. Bushing |

Fig. 43-94. Gear selector housing

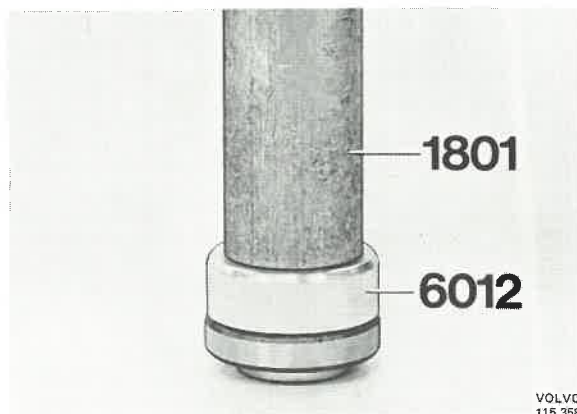


Fig. 43-95. Drift with seal

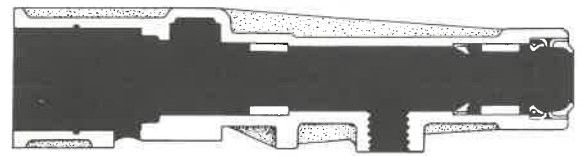


Fig. 43-96. Seals

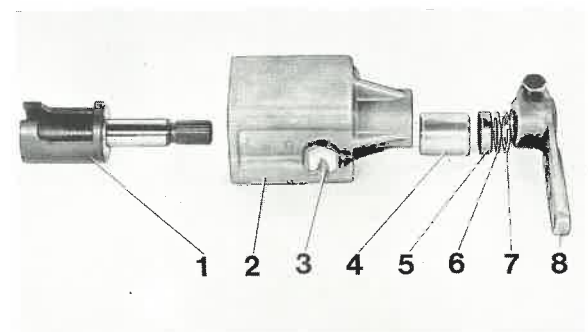
3. Fit the front roller bearing and press it down with drift 6102, Fig. 43-93. Fit the circlip.
4. Fit the rear roller bearing and press it on with 6102.

*Assembling the selector shaft housing*

1. Oil the new bushings and seals before fitting them.
2. Drive in the bushing (6 Fig 43-94) with 6011 + 1801, Fig. 43-95. Note its location.
3. Place the seal (5) on drift 6012 + 1801 and drive it into the housing. Note Fig. 43-96 to make sure that the sealing is located properly.
4. Oil the bushing (4) and drive it in.
5. Oil the seals and place them on the drift. Drive them into the housing.

*Assembling the outer selector shaft housing*

1. Oil the bushing (4 Fig 43-97) and press it into the housing with 1801 + 1784, Fig. 43-98.
2. Press in the sealing with 1801 + 1784.
3. Grease the selector shaft and place it in the housing.



- |                  |            |
|------------------|------------|
| 1. Selector fork | 5. Seal    |
| 2. Housing       | 6. Washer  |
| 3. Contact       | 7. Circlip |
| 4. Bushing       | 8. Lever   |

Fig. 43-97. Outer selector shaft housing

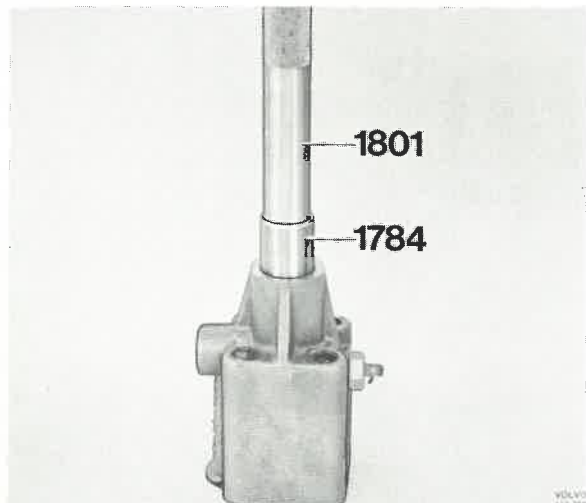


Fig. 43-98. Pressing in bushing

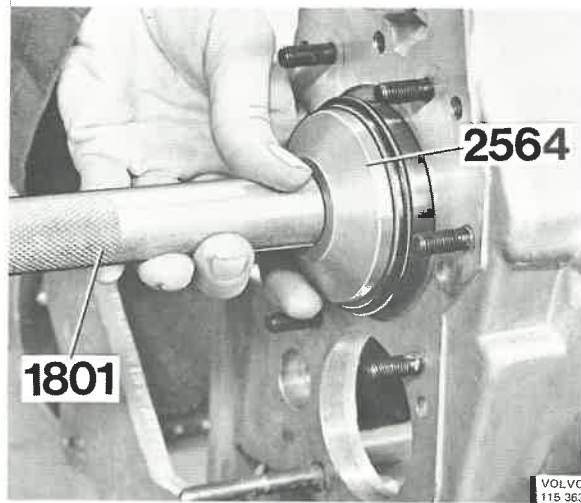


Fig. 43-100. Driving in outer race

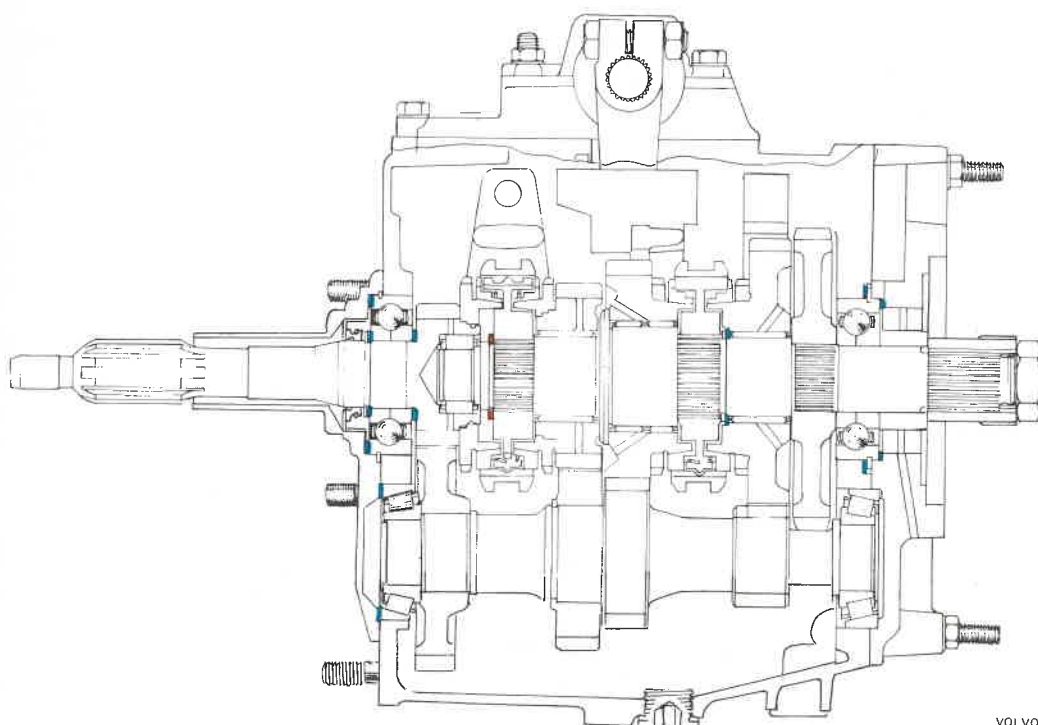
4. Turn the shaft so that it comes into the locked position. Place the lever so that it points straight down.
5. Fit the reverse light contact.

*Other assembly work on the gearbox*

In certain places, the gearbox has shims and lock rings of alternative thicknesses in order to provide a choice

to obtain the correct clearance. Fig. 43-99 shows where these places are.

1. Fix the rear half of the gearbox housing in fixture 6101.
2. Place the circlip on the bearing for the output shaft. Drive the bearing into the housing with 2564 + 1801, Fig. 43-100.



■ Circlip      ■ Shims

Fig. 43-99. Alternative shims and circlips in gearbox

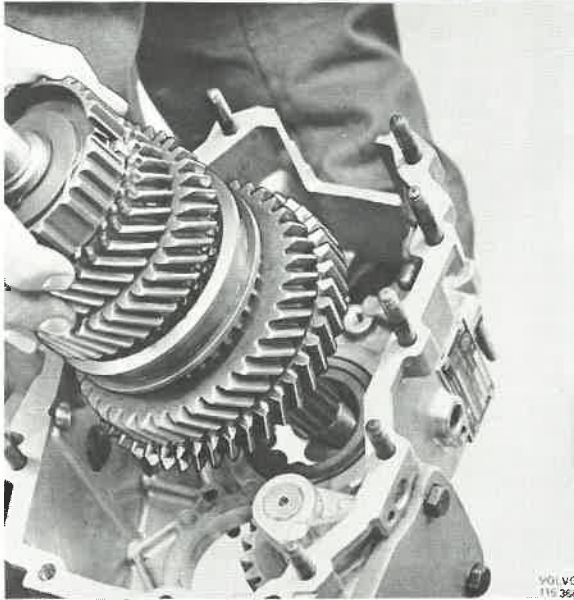


Fig. 43-101. Fitting output shaft

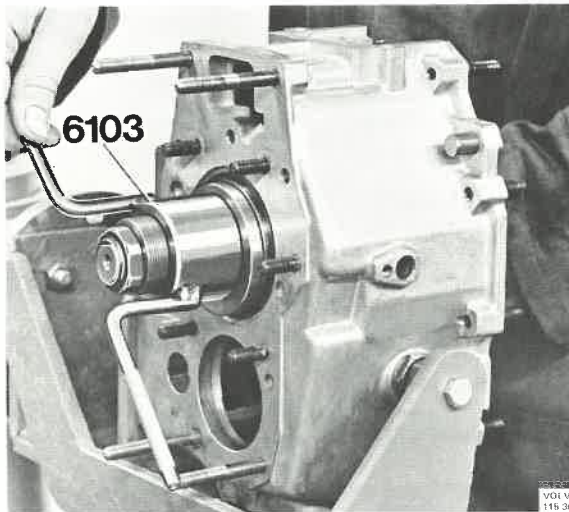


Fig. 43-102. Pulling in bearing

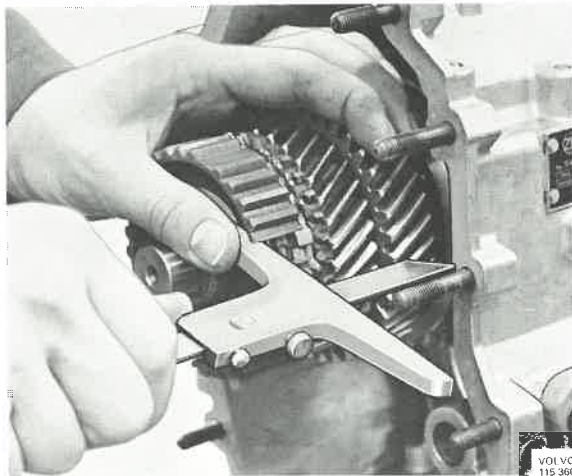


Fig. 43-103. Checking distance

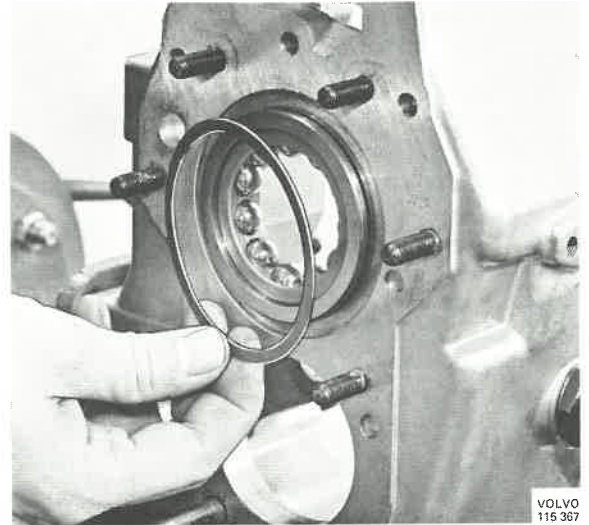


Fig. 43-104. Placing circlip

3. Place the output shaft in the housing, Fig. 43-101. Centre the shaft properly in the bearing. Fix on press tool 6103 and drive in the sprindle so that the shaft is held in position, Fig. 43-102. Check that the inner race on the output shaft is correctly centered in the bearing when the tool is pulled in.

4. With a depth gauge measure the distance from 3rd-4th synchronizing hub to the gearbox housing face, Fig. 43-103.

Reduce the measurement by 53.5 mm (2.1") and the difference may be  $\pm 0.1$  mm (0.0039"). If the measurement is greater, a shim of corresponding difference should be placed between the housing

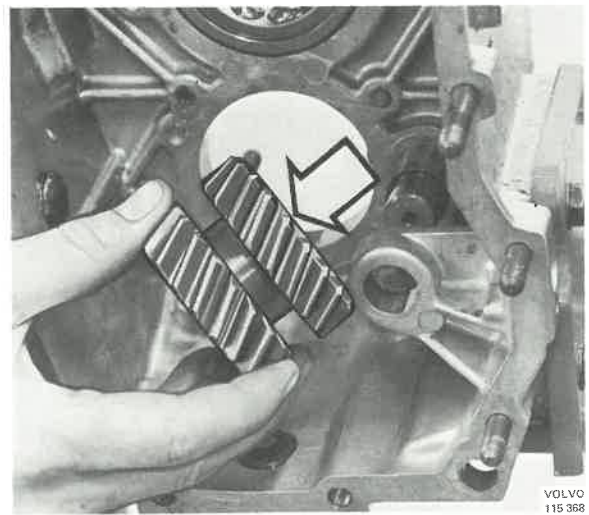


Fig. 43-105. Placing reverse gear

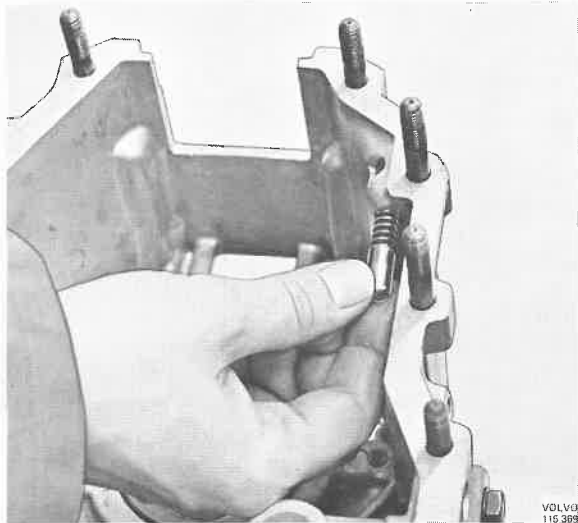


Fig. 43-106. Placing lock pin

and the circlip on the output shaft bearing. Shims are available in sizes 0.6, 0.8, 1.0, 1.2 and 1.4 mm (0.024, 0.032, 0.039, 0.048 and 0.056").

5. Remove the tool and lift off the output shaft. Drive out the output shaft bearing approx. 2 mm (0.08") with 1801 + 2564. Remove the circlip and place the requisite shims in position, Fig. 43-104. Fit the circlip and drive in the bearing.
6. Fit the reverse drive in the gearbox. Note that the gear with the bevelled teeth must face the rear end of the gearbox, see Fig. 43-105.
7. Turn the gearbox. Grease the lock pins for 1st-2nd and reverse gears and place them and the springs in the housing, Fig. 43-106.

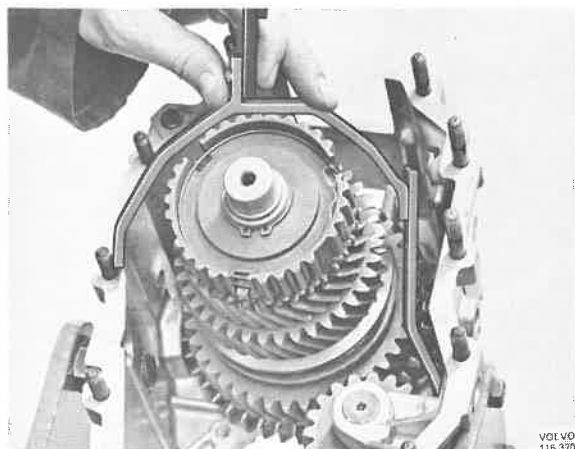


Fig. 43-107. Fitting selector fork

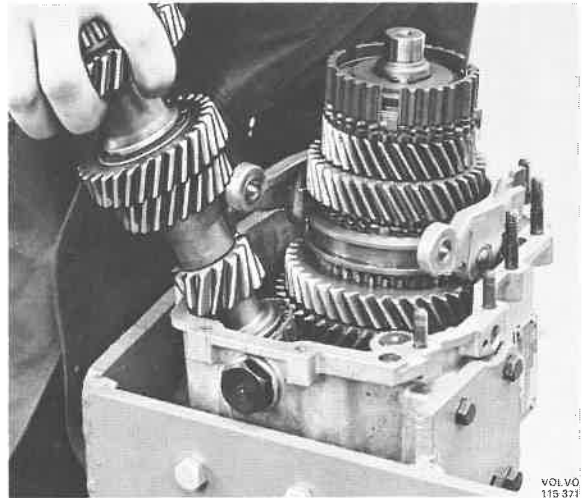


Fig. 43-108. Fitting countershaft

8. Fit the output shaft and selector fork for reverse gear, Fig. 43-107, and the selector fork for 1st-2nd engaging sleeve.
9. Lift up the output shaft and reverse gear and fit the countershaft, Fig. 43-108.
10. Centre the output shaft in the rear bearing. Fix press tool 6103 on the shaft.
11. Place in position the spring for 3rd-4th synchronizing. Note that it should be placed with the resilient part anti-clockwise, Fig. 43-109. Grease the interlock units and fit them, Fig. 43-110. Fit the selector fork on 3rd-4th engaging sleeve and fit the sleeve on the hub.

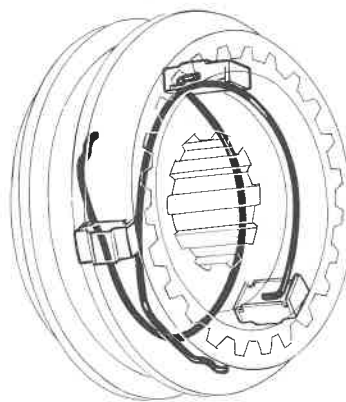


Fig. 43-109. Placing springs

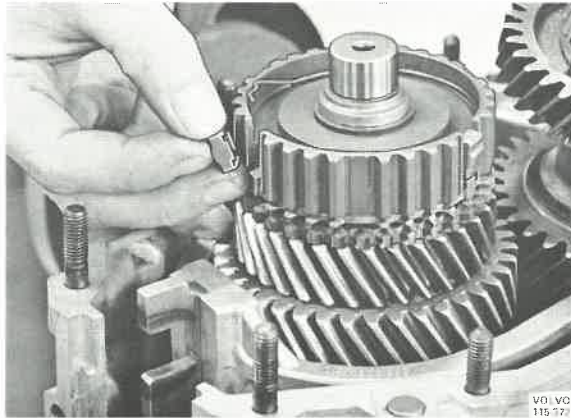


Fig. 43-110. Fitting lock units

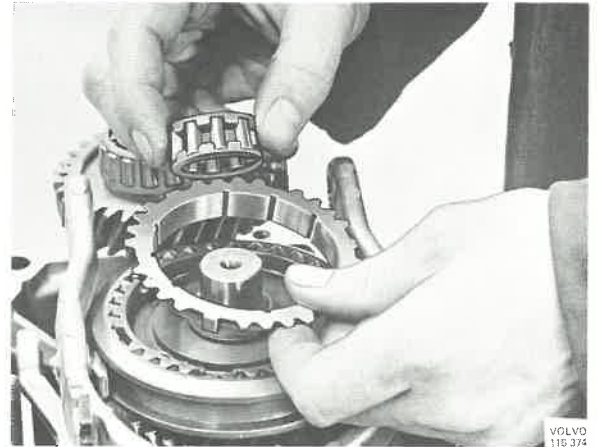


Fig. 43-113. Fitting roller bearing and cone

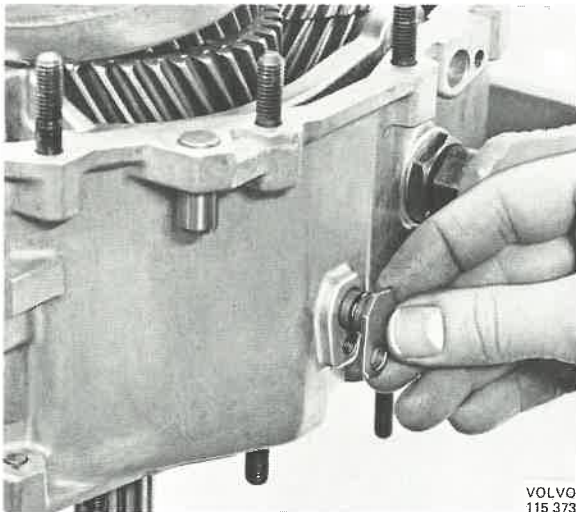


Fig. 43-111. Fitting bearings pins

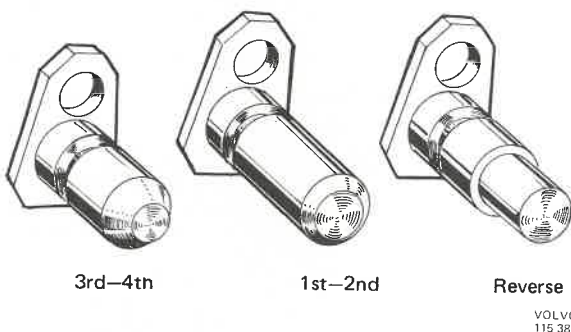


Fig. 43-112. Bearing pins

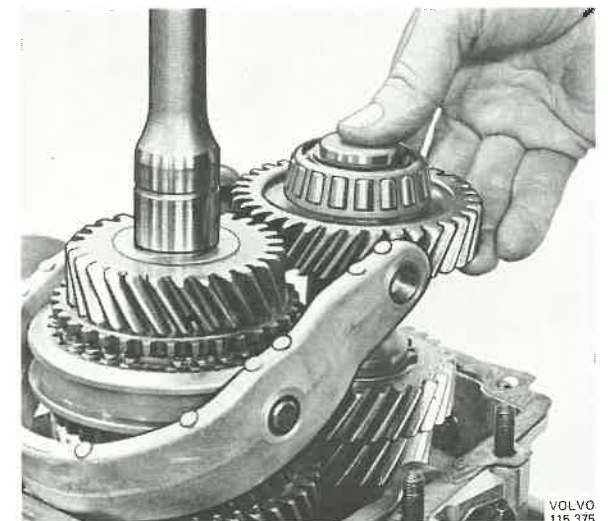


Fig. 43-114. Checking countershaft

12. Fit the bearing pins in the selector forks for reverse and 1st-2nd, see Fig. 43-111. There are three types of bearing pins, see Fig. 43-112.
13. Place the roller bearing and synchronizing on the output shaft, Fig. 43-113. Fit the input shaft in position.
14. Place a new gasket on the gearbox housing. Check that the countershaft is fitted properly, Fig. 43-114. Grease the lock pin for 3rd-4th.
15. Place the spring and pin in the front housing half.
16. Fit the two sections together. Check that the interlock for 3rd-4th selector fork takes up its correct position. Fit all washers and nuts holding the housing halves together. Knock in the guide pins. Tighten the nuts to a torque of 20-25 Nm (2.0-2.5 kpm =

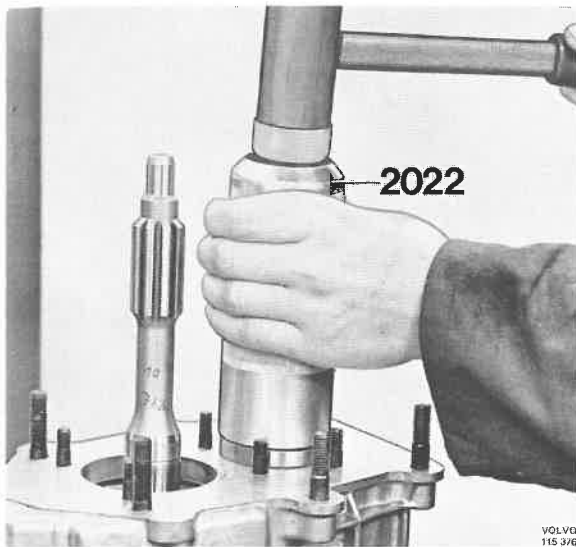


Fig. 43-115. Driving in outer race

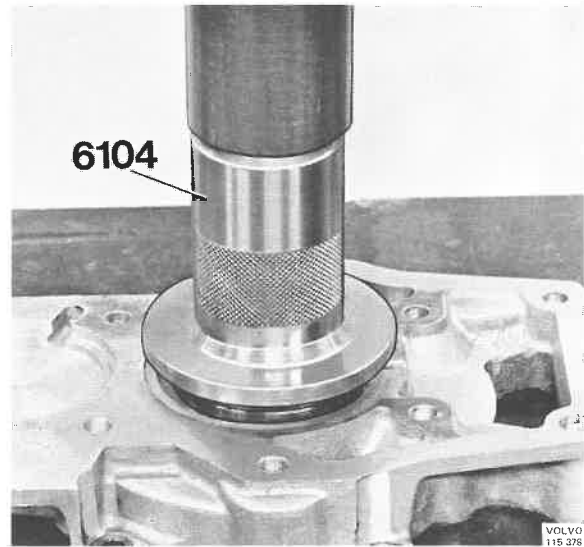


Fig. 43-117. Driving in seal

- 14–18 lbftf) and the Allen bolts to a torque 8–12 Nm (0.8–1.2 kpm = 5.8–8.7 lbftf).
17. Fit the bearing pins for 3rd–4th selector fork. Fit the bolts.
  18. Drive in the outer race for the countershaft front bearing with 2022, Fig. 43-115.
  19. Turn round the gearbox and drive in the outer race for the rear bearing with 2022. Engage two gears.
  20. Remove press tool 6103 from the output shaft. Place the bearing inner race on the shaft. Fix on the tool and press in the race, Fig. 43-116. Remove the tool.
  21. Place a new seal for the rear cover on the gearbox. Check that the countershaft bearing is in its bottom position.
  22. Drive new seals into the rear cover, Fig. 43-117, with 6104. Measure the depth of the machined recess in the rear cover for the output shaft bearing, Fig. 43-118. Measure the distance between the bearing and the face of the seal, Fig. 43-118. The difference between the two measurements may be  $\pm 0.05$  mm (0.002"). Shims are available in the following sizes: 0.2, 0.5, 0.6, 0.7, 0.8, 0.9 and 1.0 mm (0.016, 0.020, 0.024, 0.028, 0.032, 0.036 and 0.039"). Grease the seal in the cover and fit on the cover.

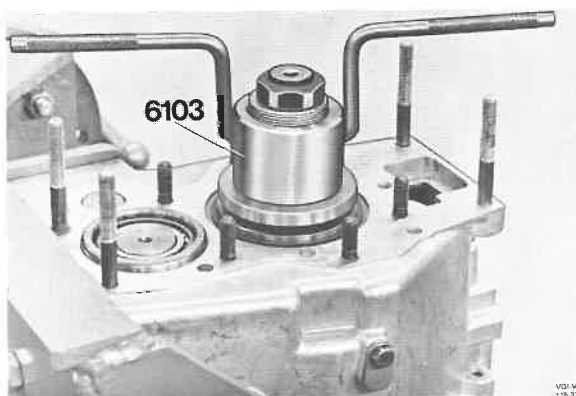


Fig. 43-116. Pressing in inner race

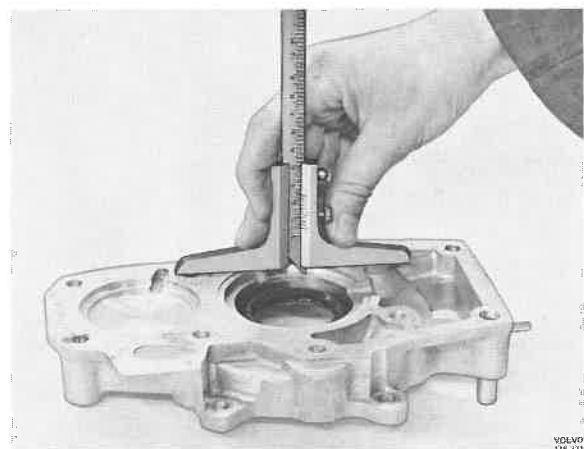


Fig. 43-118. Calculating clearance

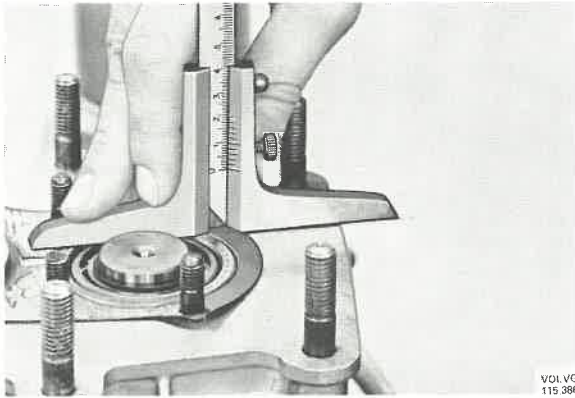


Fig. 43-119. Calculating clearance

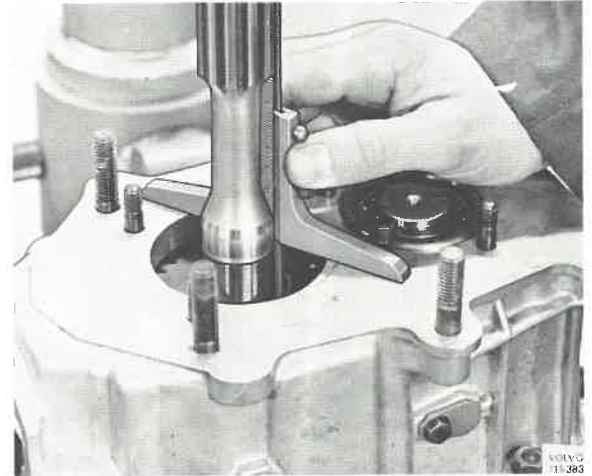


Fig. 43-121. Calculating clearance

23. Place the shim on the bearing. Fit the wear ring, Check that the cover bottoms properly against the gearbox before fitting the washers and nuts in position. Tighten the nuts to a torque of 20–25 Nm (2.0–2.5 kpm = 14–18 lbftf).
24. Fit on the gear and the nut. Tighten the nut to a torque of 140–160 Nm (14–16 kpm = 101–115 lbftf). Lock the nut by peening the edge of the nut, Fig. 43-120.
25. Turn the gearbox. Disengage the gears and rotate the input shaft.
26. Measure the distance from the gearbox housing, Fig. 43-121, to the contact surface of the bearing on the input shaft.

Fit the circlip on the bearing and measure the distance from the circlip to the edge of the

bearing, Fig. 43-122. The difference between the two measurements may be 0.5–0.7 mm (0.020–0.028”), which is the clearance. If the distance is greater, fit a shim of corresponding size on the input shaft.

Shims are available in the following sizes: 0.5, 0.6, 0.7, 0.8, 0.9, 1.0, 1.1, 1.2, 1.3, 1.4 and 1.5 mm (0.020, 0.024, 0.028, 0.032, 0.036, 0.039, 0.044, 0.048, 0.052, 0.056 and 0.060”).

27. Engage two gears.

Place the inner race and outer race on the input shaft. Place the inner race on the bearing and check that it fits properly on the bearing. Turn the thread insert in the tool. Fix in position the press tool with the tool stop washer between the spline and the tool, Fig. 43-123. Press the bearing into the housing. Then tap on the end of

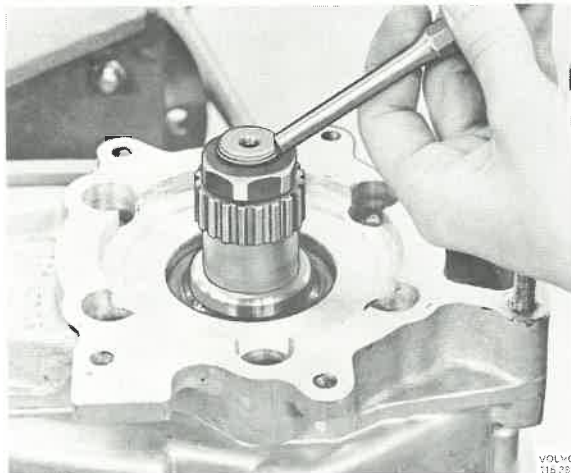


Fig. 43-120. Nut locking

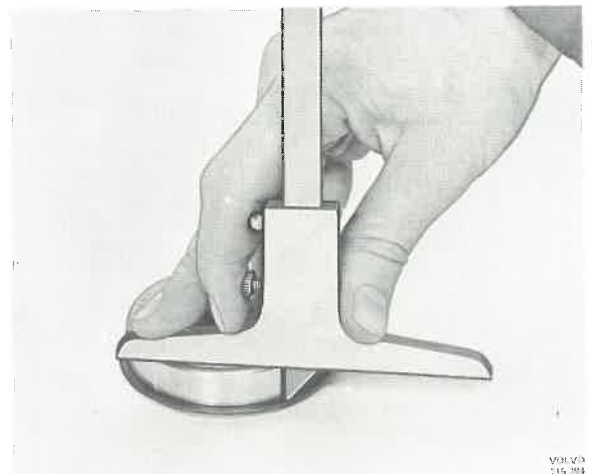


Fig. 43-122. Calculating clearance

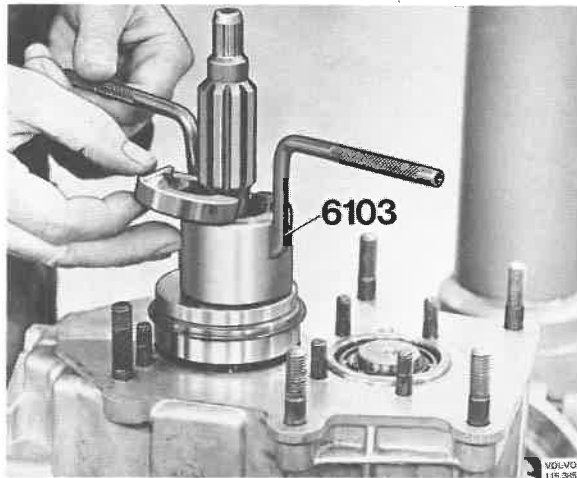


Fig. 43-123. Pressing in bearing

the input shaft a plastic mallet so that the bearing circlip goes down against the housing.

28. Remove the press tool. Place the shim between the bearing and circlip which gives minimum clearance. The adjuster washer is of the same type as that placed behind the bearing.
29. Disengage the gears.

Tap in the countershaft to the bottom while rotating the input shaft at the same time. Knock down the outer race. Place a new seal for the front cover on the gearbox. Measure the distance from the outer race on the input shaft bearing to the seal. Measure the distance from the outer race on the countershaft bearing to the seal. Fig. 43-124.

30. Measure the distance from the contact face on the cover to the recesses for the outer races for the bearings, Fig. 43-125. The difference between the measurements obtained may be  $\pm 0.05$  mm (0.002") for the input shaft and from 0 to +0.1 mm (0.0039") on the countershaft.

Shims are available in the following sizes: Input shaft: 0.4, 0.5, 0.6, 0.7, 0.8, 0.9 and 1.0 mm (0.016, 0.020, 0.024, 0.028, 0.032, 0.036 and 0.039"). Countershaft: 0.5, 0.7, 0.8, 0.9, 1.0, 1.1, 1.2, 1.3, 1.4 and 1.5 mm (0.020, 0.028, 0.032, 0.036, 0.039, 0.044, 0.048, 0.052, 0.056 and 0.060").

31. Drive a new seal into the cover.

Place the shims required on the bearings for the input shaft and countershaft. Fit the cover and make sure that it is fitted properly against the gearbox before tightening up the bolts with the

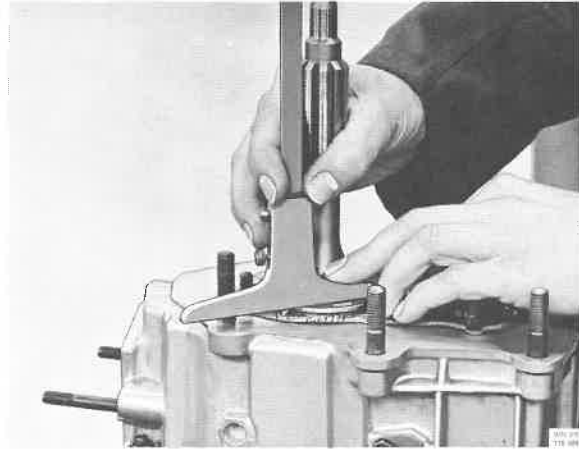


Fig. 43-124. Calculating clearance

washers. Tighten the bolts to a torque of 22-25 Nm (2.2-2.5 kpm = 16-18 lbftf).

32. Fit the clutch casing and all washers and nuts. Tighten the nuts to a torque of 41-51 Nm (4.1-5.1 kpm = 30-37 lbftf). Grease the throw-out shaft and insert it in the casing while placing in position the throw-out fork. Grease the neck of the input shaft cover and fit on the throw-out bearing. Tighten the fork bolts.
33. Turn the gearbox to the horizontal position. Place the gear shift bar for 1st-2nd in position. Place a new gasket for the selector shaft housing on the gearbox.

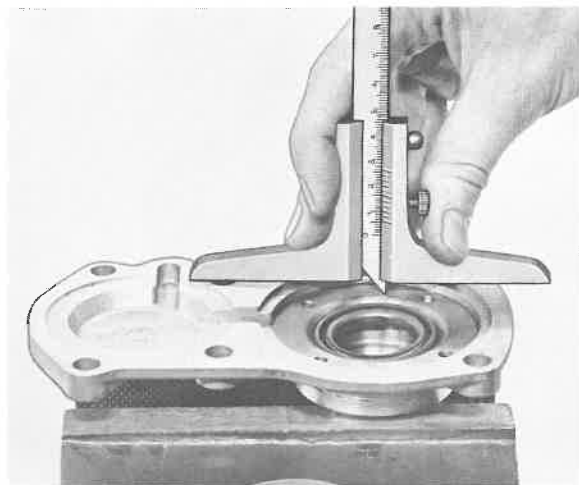


Fig. 43-125. Calculating clearance

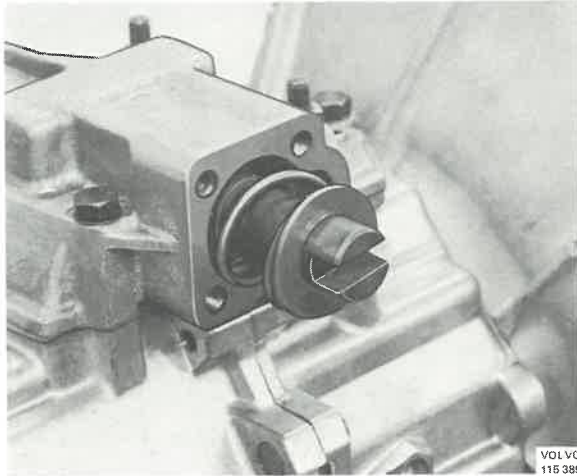


Fig. 43-126. Small spring with spacer rings

34. Fit on the selector shaft housing. Fit washers and bolts. Grease the selector shaft and place it in the housing. Fit the lock pin and the lock ring in the housing. Fit the spacer ring, the small spring, washer, spacer ring, Fig. 43-126, the large spring, washer, Fig. 43-127, and the lock ring. Place the lug in position and drive in the tubular pin on the shaft.
35. Fit the selector shaft housing outer part. Fit the bolts and tighten them to a torque of 100-120 Nm (10.0-12.0 kpm = 72-86 lbftf). Fit the reverse inhibitor pawl on the selector shaft housing. Place the cover and lever on the selector shaft.

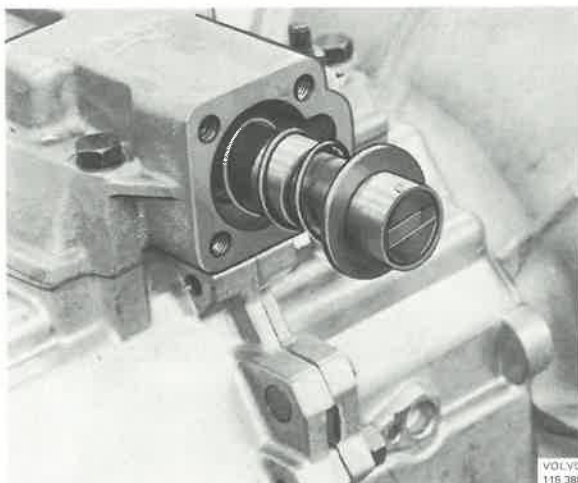


Fig. 43-127. Large spring with washer

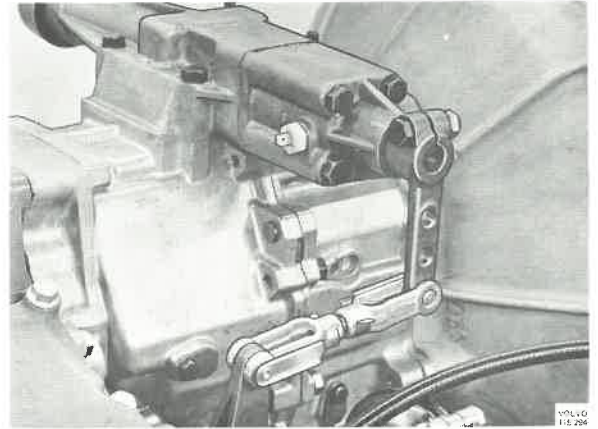


Fig. 43-128. Lever with link

36. Coat the outer cover on the gearbox with sealing agent and oil the drive on the output shaft. Fit the auxiliary gearbox and all nuts and washers. Tighten up the nuts. Fit the cover on the auxiliary gearbox using a new gasket.
37. Place the lever on the gearbox selector shaft housing and the auxiliary gearbox in neutral. The hole in the gearbox lever and link should coincide so that the lock pin fits easily, compare Fig. 43-128. If necessary adjust the link fork.

### Installing the gearbox

Special tool: 6128, 6136

1. Place the gearbox on a jack, see Fig. 43-129.

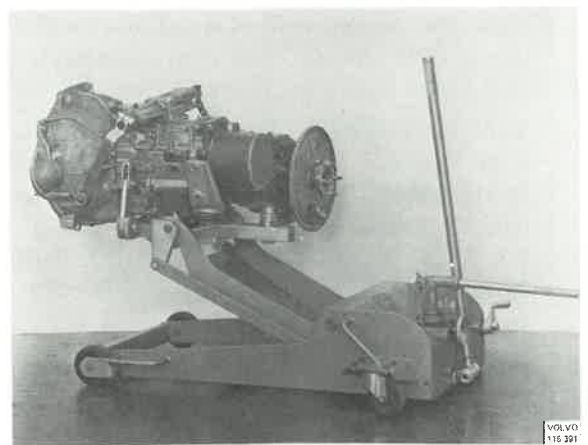


Fig. 43-129. Gearbox on jack

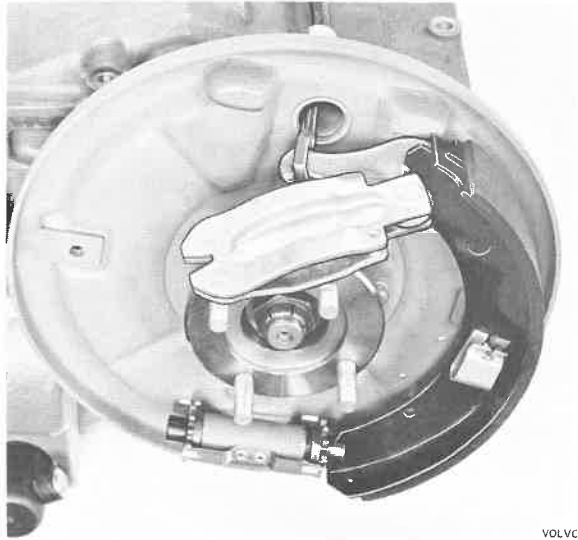


Fig. 43-130. Fitting brake shoe

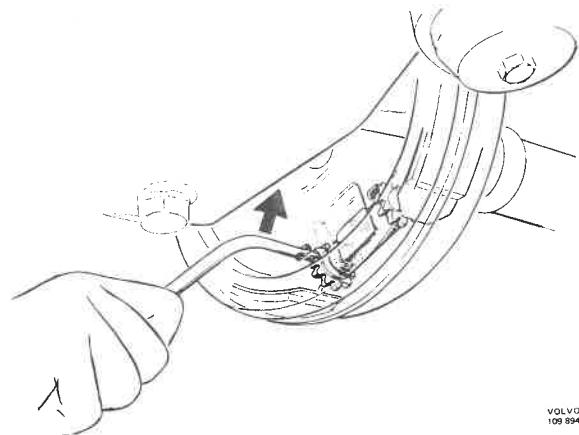


Fig. 43-131. Adjusting brake shoe

2. Push the gearbox on the jack in under the vehicle. Jack up the gearbox so that the input shaft comes opposite the clutch disc lands.
3. Engage a gear. Rotate the output shaft on the auxiliary gearbox while pushing the gearbox at the same time. Place in position the plate for the exhaust manifold bracket.
4. Fit the other bolts round the casing.
5. Place the starter motor in position and fit and tighten up the bolt.
6. Mount the bracket for the exhaust manifold. Fit the parking brake wire in position.
7. Fit and screw tight the bolts for the rear engine mounts. Remove the gearbox jack or lifting tool 6136 from the auxiliary gearbox.
8. Fit the lower bolts round the clutch casing. Fix the earth connection (pleat) to the casing.
9. Assemble the propeller shaft brake. Fit first the lower brake shoe. Then fit the lever, Fig. 43-130, the upper return spring, the upper shoe, the lower return spring and the drum.
10. Adjust out one of the brake shoes with a screwdriver, Fig. 43-131, until it is just possible to rotate the drum. The drum should be fixed with nuts. Slacken the adjuster screw until the drum rotates freely, but max. five teeth. Adjust the other brake shoe in the same way.
11. Check the function of the parking brake lever. If the parking brake does not function properly at the 4th ratchet in spite of the fact that the propeller shaft brake has been properly adjusted, alter the length of the wire by means of the nut at the front end.
12. Install the front and rear propeller shafts.
13. Install the silencer. Screw tight the flange bolts. Fit the attachment for the exhaust manifold.
14. Remove the attaching plate and tighten up the cylinder head bolts to a torque of 90 Nm (9 kpm = 65 lbfft).
15. Fit and secure the clutch wire sleeve on the clutch casing. Tighten up the nuts. Fit and secure the fork on the clutch lever. Adjust the lever play with the help of the sleeve nuts. The play should be 4-5 mm (0.16-0.20"), see Fig. 43-132.

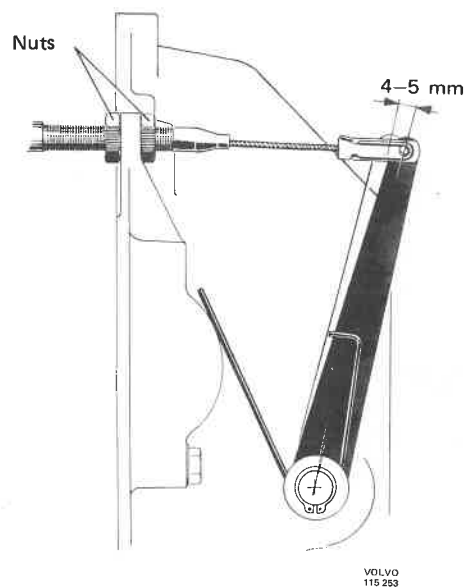


Fig. 43-132. Clutch clearance

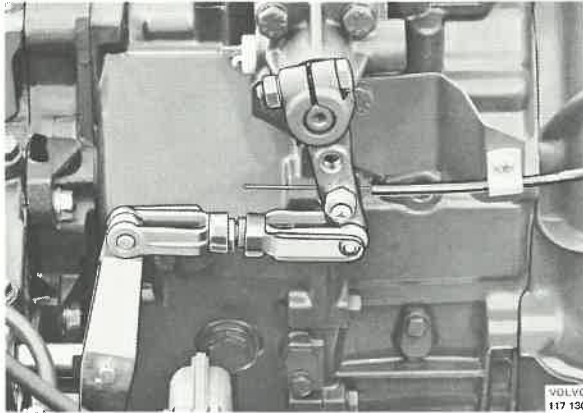


Fig. 43-133. Fitting the cable

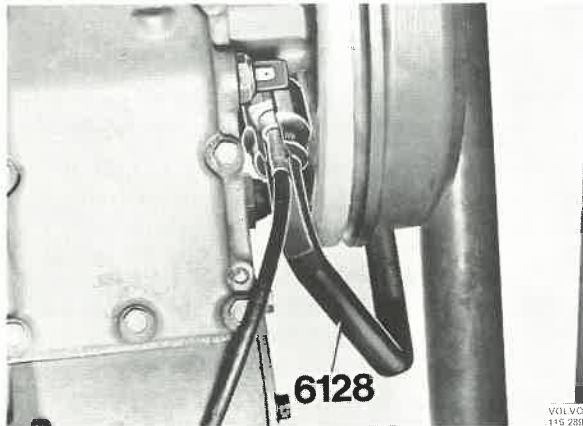
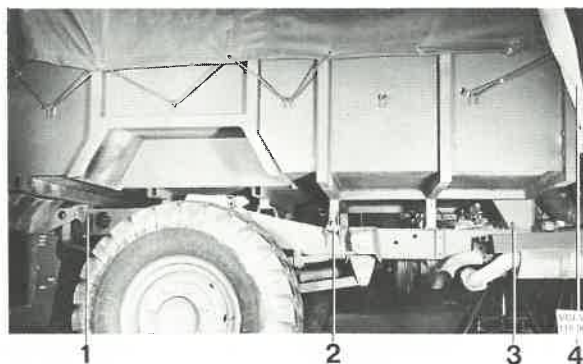


Fig. 43-134. Fitting speedometer wire



- |            |                 |
|------------|-----------------|
| 1. Bolting | 3. U-bolts      |
| 2. Bolting | 4. Hoist straps |

Fig. 43-135. Fitting the platform

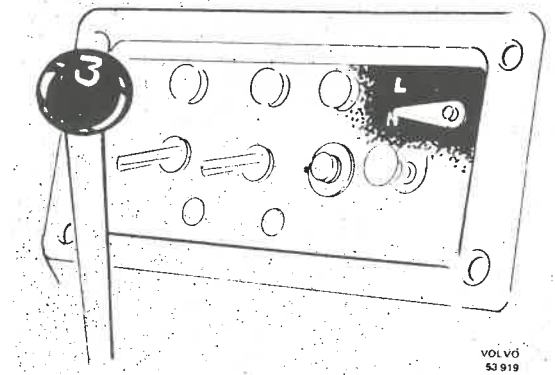


Fig. 43-136. Fitting the indicator arrow

16. Fit and secure the gear shift bar to the gearbox lever. Fit and secure the cross stay.
17. Place the auxiliary gearbox in neutral. Fix the cable for the gear position indicator in the lever, see Fig. 43-133.
18. Screw tight the speedometer wire with 6128. See Fig. 43-134.
19. Connect up the evacuation hoses to the gearbox, auxiliary gearbox and clutch casing.
20. Fit the hose to the control mechanism on the auxiliary gearbox. Connect the cables to the senders on the gearbox auxiliary gearbox.
21. Fill the gearbox and auxiliary gearbox with oil, if these units have been emptied of oil. Concerning quantity and quality, see under "Data".
22. Place the platform, see Fig. 43-135, in position and tighten the bolts and U-bolts.
23. Check that the indicator arrow, see Fig. 43-136, points to N, when the auxiliary gearbox is in neutral. If necessary, adjust the arrow by slackening the nut and turning the arrow to point to N. Tighten up the nut again.
24. Connect up the earth cable to the battery and fit on the cover.

## AUXILIARY GEARBOX

### Removing the auxiliary gearbox

Special tools: 2116, 6128

1. Drain the oil from the auxiliary gearbox. Engage reverse and low gear.
2. If the gearbox is removed with a block and tackle and the vehicle has a platform superstructure, the platform must be removed. This is done after removing the bolts and U-bolts, see Fig. 43-138. Remove the platform with a hoist straps which is fixed to the lifting eyelets, see Fig.

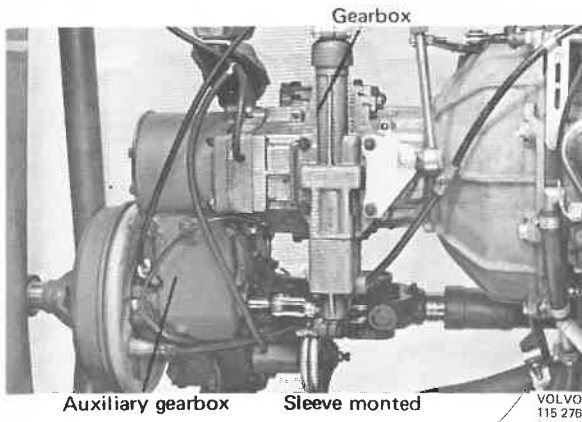


Fig. 43-137. Auxiliary gearbox in vehicle

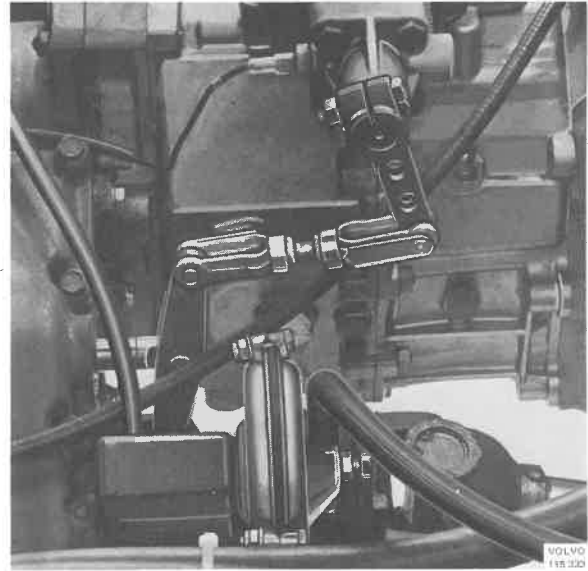
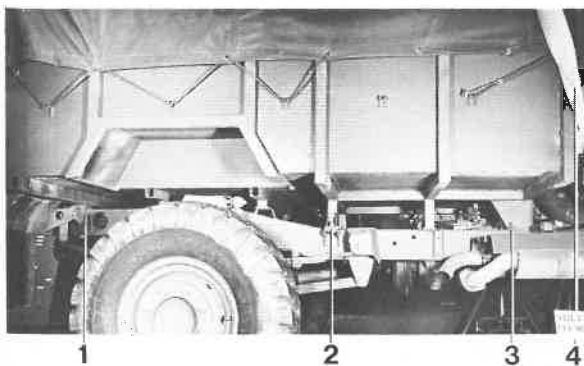


Fig. 43-139. Link between gearbox and auxiliary gearbox

3. Remove the link, Fig. 43-139, from the auxiliary gearbox. Remove the wire from the shift indicator, see Fig. 43-133, from the outer gear shaft housing.
4. Remove the evacuation and vacuum hoses for the auxiliary gearbox control mechanism. Disconnect the electric cable for the auxiliary gearbox sender.
5. Unscrew the speedometer cable with 6128, Fig. 43-140.  
If the wire does not loosen from the bearing, remove the lock bolt for the bearing and remove the bearing from the auxiliary gearbox. Make sure dirt does not get into the gearbox.

Fit the attaching plate 6129 to the cylinder head bolts and place lift tool 6136 as shown in Fig. 43-141.

6. Release the parking brake. Remove the rear propeller shaft from the auxiliary gearbox and differential carrier. Remove the front propeller shaft from the auxiliary gearbox. Remove the exhaust pipe outer attachment. Remove the bolts at the flange on the silencers. Remove the silencers and the rear exhaust pipe section.
7. Remove the propeller shaft brake drum. Remove the brake shoes. Disconnect the wire from the lever on the propeller shaft brake.



- |            |                 |
|------------|-----------------|
| 1. Bolting | 3. U-bolts      |
| 2. Bolting | 4. Hoist straps |

Fig. 43-138. Removing the platform

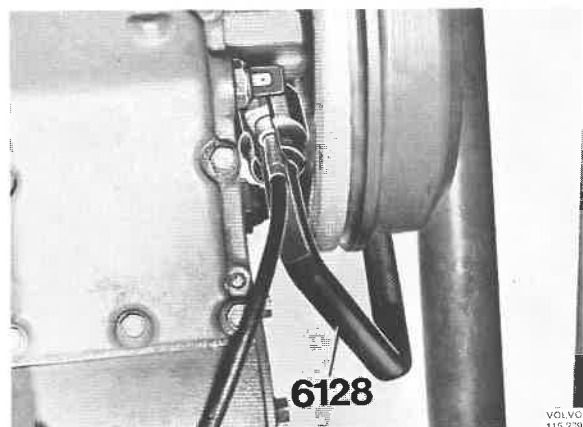


Fig. 43-140. Removing speedometer wire

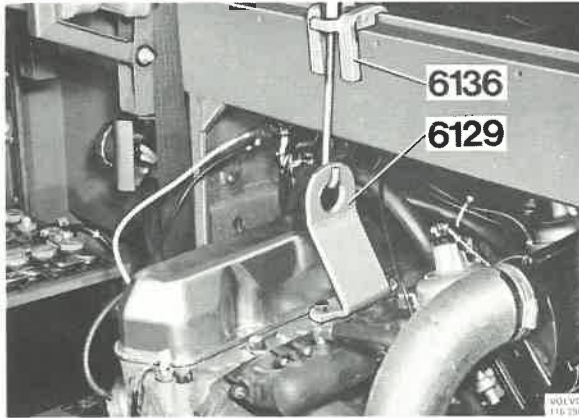


Fig. 43-141. Fitting the attaching plate

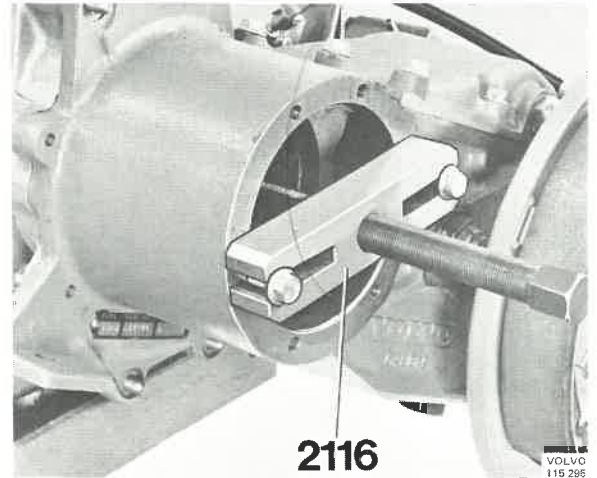


Fig. 43-144. Removing auxiliary gearbox

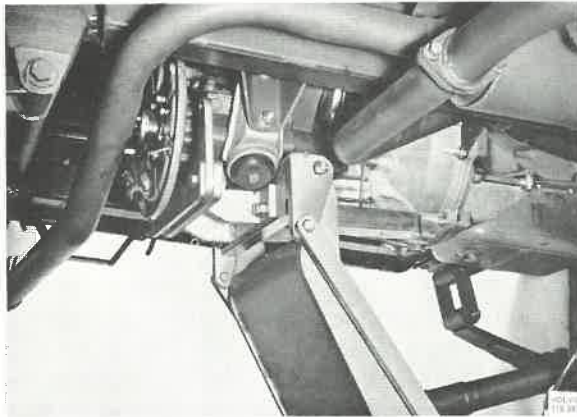


Fig. 43-142. Jack under auxiliary gearbox

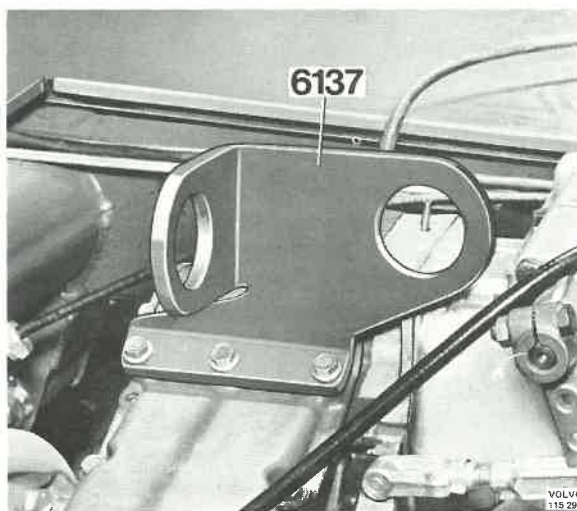


Fig. 43-143. Fitting the bracket

8. Place the gearbox jack under the auxiliary gearbox gear assembly, see Fig. 43-142. Lower the jack so that the engine rests on its mounts. Remove the bolts securing the rear engine mounts. Lower the auxiliary gearbox. Remove the lower bolts holding the gearbox and auxiliary gearbox together. Use bracket 6137 (see Fig. 43-143) when removing the auxiliary gearbox with the help of a block and tackle.
9. Remove the rear cover. Remove the nut on the gearbox output shaft. Fit the puller tool 2116, Fig. 43-144.
10. Remove the bolts and nuts holding the gearbox and auxiliary gearbox together.
11. Screw in the puller tool spindle. Remove the tool. Lower the auxiliary gearbox when it has released from the gearbox. Lower the gearbox.

#### Disassembling the auxiliary gearbox

Special tools: 1801, 2039, 2097, 2261, 2267, 2291, 2337, 2395, 2837, 6140

1. Place the auxiliary gearbox in fixture 6140 and secure the unit on an overhaul stand, see Fig. 43-145.
2. Use counterhold 2837 and remove the nuts on the front and rear output shafts. **NOTE!** Take a firm hold of the tool when slackening the nut (otherwise the control mechanism can get damaged).

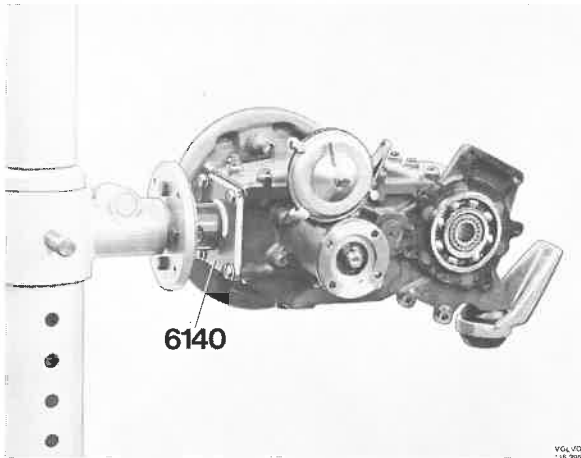


Fig. 43-145. Auxiliary gearbox in vice

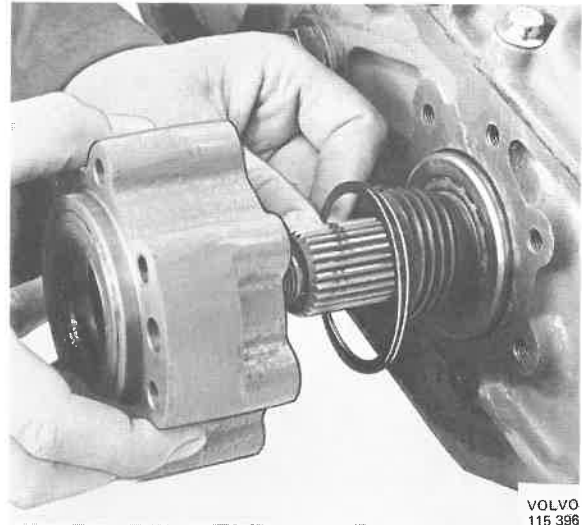


Fig. 43-147. Removing rear housing half

Remove the flanges with 2261, Fig. 43-146.

3. Remove the propeller shaft brake backing plate.
4. Remove the rear housing and the shims, Fig. 43-147. Remove the speedometer pinion.
5. Remove the control housing for the front wheel drive.
6. Remove the cover on the auxiliary gearbox, Fig. 43-148.
7. Remove the nut on the intermediate gear shaft, Fig. 43-149. (If necessary use a shift spanner as counterhold.)
8. Remove the circlip for the cluster gear bearing, Fig. 43-149. Place the auxiliary gearbox in a press with the rear part of the box resting on the press table. Check that the bearing for the output shaft runs freely. Use a drift with the same

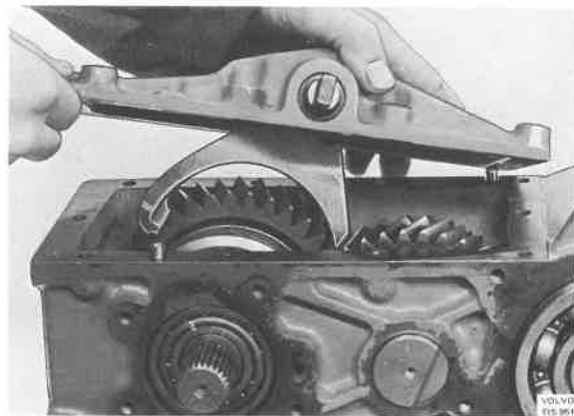


Fig. 43-148. Removing cover

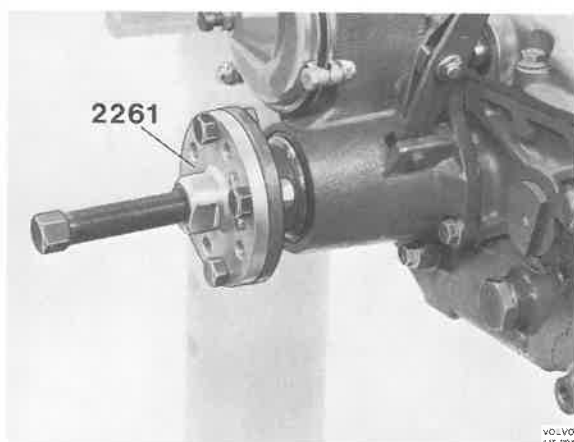


Fig. 43-146. Removing flange

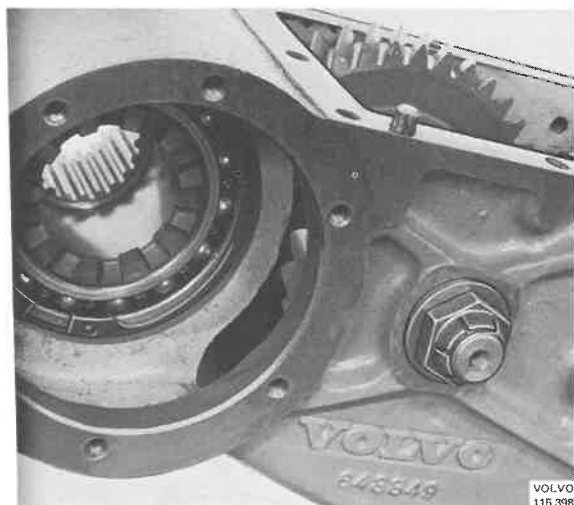


Fig. 43-149. Circlip cluster gear, nut, intermediate gear

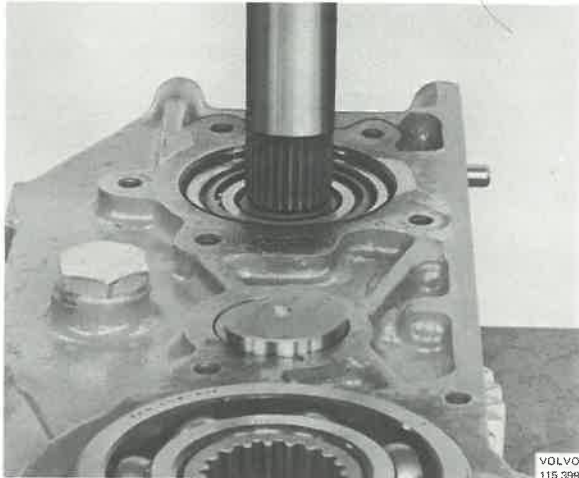


Fig. 43-150. Pressing out output shaft

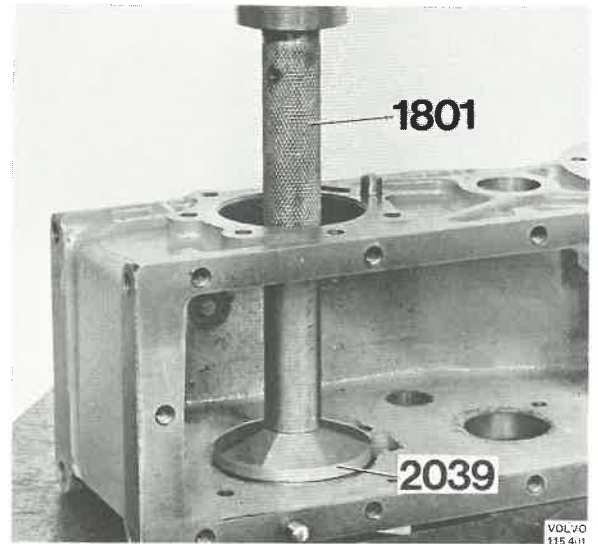


Fig. 43-153. Driving out outer races

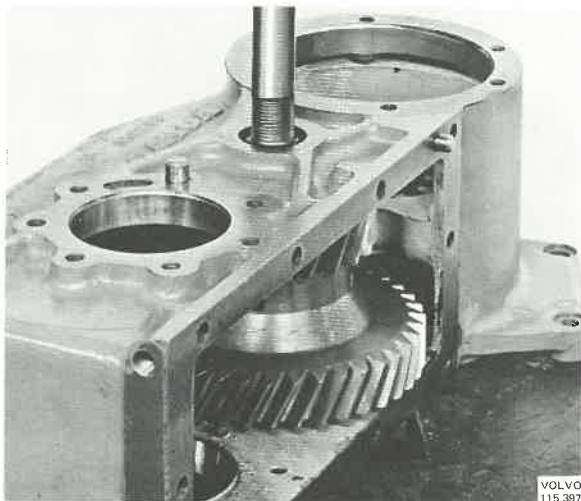


Fig. 43-151. Pressing out shaft, intermediate gear

diameter as that of the shaft, Fig. 43-150. Press out the shaft and take hold of it underneath. Take care of the outer race, output shaft and needle bearings. Lift out the synchronizing with the high and low speed gears, also the roller bearing.

9. Turn the auxiliary gearbox. Press out the intermediate gear shaft. Use a drift with the same diameter as that of the shaft, Fig. 43-151. Lift out the intermediate gear with bearing, spacer sleeve and shim.
10. Press out the cluster gear and bearing with 2291, Fig. 43-152.
11. Press out the outer race for the output shaft bearing with 1801 + 2039, Fig. 43-153.

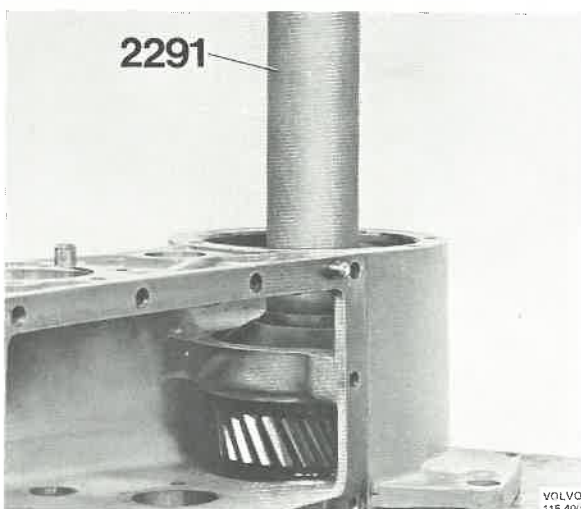


Fig. 43-152. Pressing out cluster gear

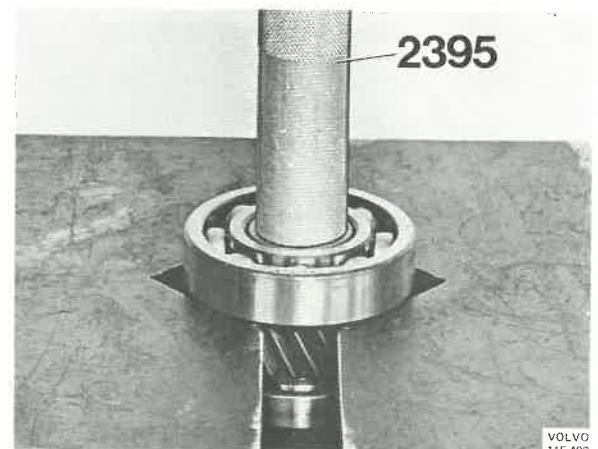


Fig. 43-154. Removing bearing

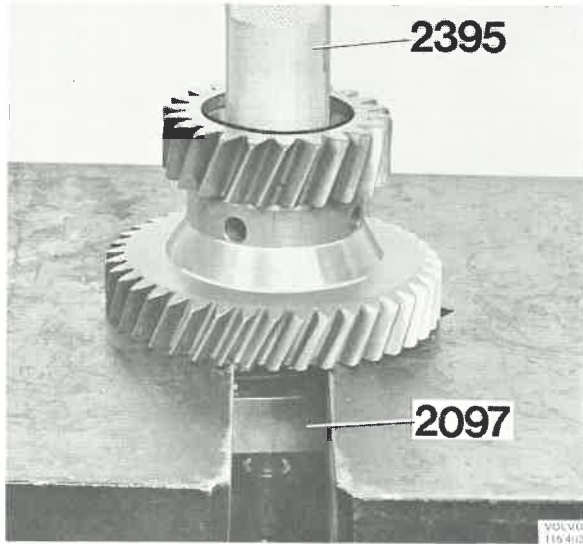


Fig. 43-155. Pressing out outer races

#### Disassembling the cluster gear

1. Place the cluster gear in a press, see Fig. 43-154, and press off the bearing with 2395.
2. Turn the gear and press off the other bearing with 2395.

#### Disassembling the intermediate gear

1. Remove the shims, spacer sleeve and inner race.
2. Press out the outer races from the intermediate gear with 2097 + 2395, Fig. 43-155.

#### Disassembling the synchronizing and output shaft gear

1. Remove the thrust washer, needle bearing and bearing race from the high speed gear wheel.

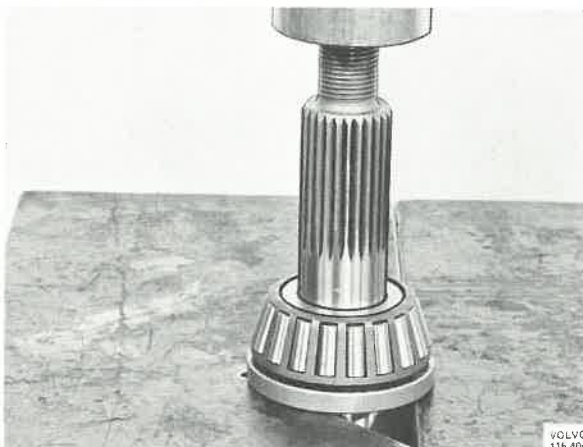


Fig. 43-156. Removing bearing

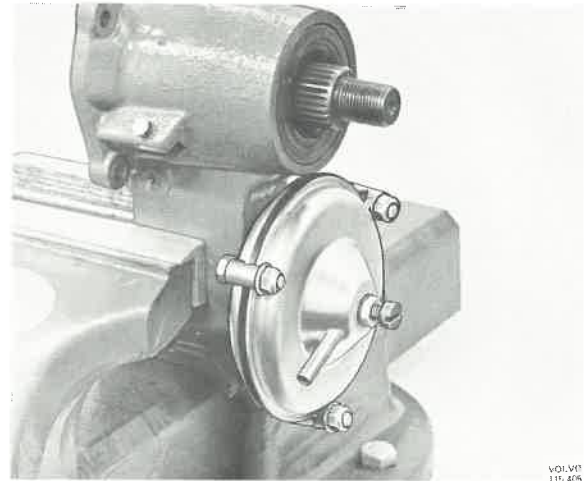


Fig. 43-157. Fitting control mechanism

2. Remove the gear wheel for the high speed and the synchronizing cone.
3. Remove the synchronizing from the low-speed gear wheel.
4. Disassemble the synchronizing.

#### Disassembling the output shaft

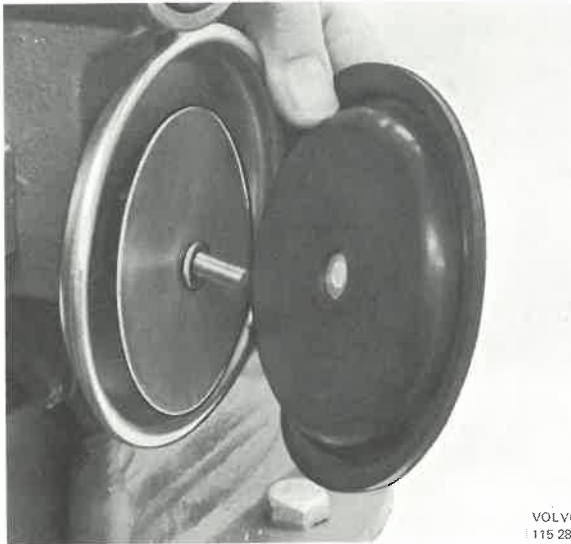
Place the shaft in a press with counterhold under the thrust washer, Fig. 43-156, and press off the bearing.

#### Disassembling the control mechanism

1. Fix the control mechanism securely in a vice, see Fig. 43-157.
2. Remove the bolts securing the cover to the control cylinder. Remove the cover and the thrust spring, Fig. 43-158.

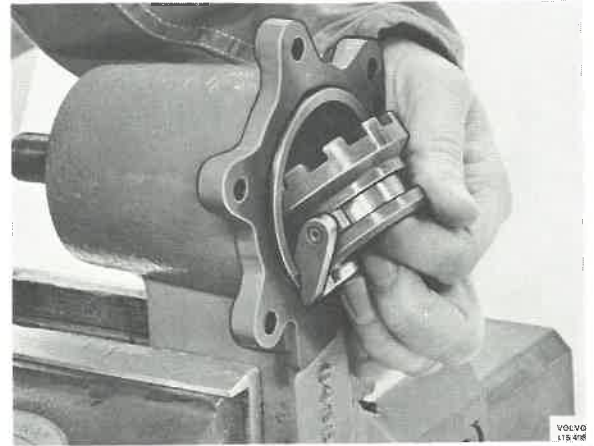


Fig. 43-158. Removing cover and spring



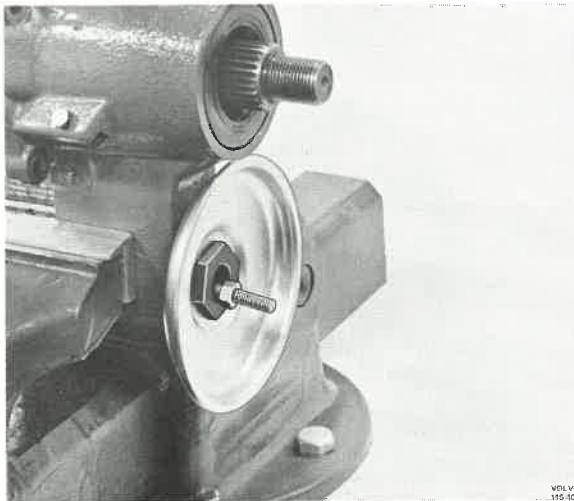
VOLVO  
115 281

Fig. 43-159. Removing diaphragm



VOLVO  
115 298

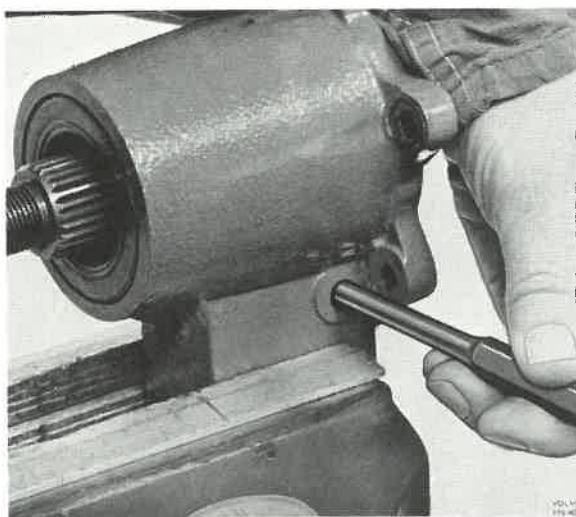
Fig. 43-162. Removing engaging sleeve



VOLVO  
115 406

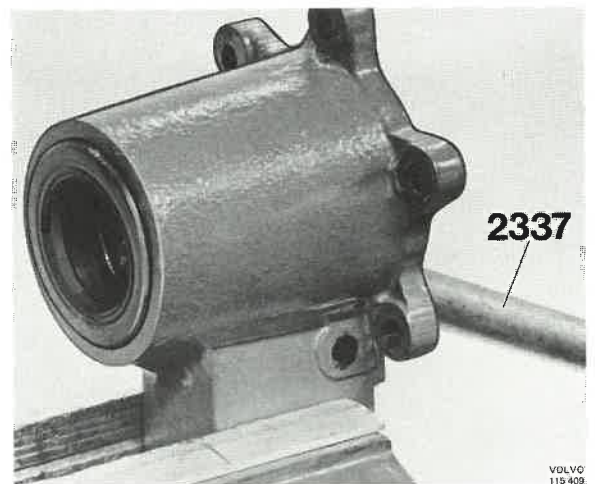
Fig. 43-160. Holed nut

3. Remove nut on the push rod. Remove the washer and the diaphragm, Fig. 43-159. Take care of the spacer washer on the push rod and remove the other washer.
4. Remove the holed nut securing the control cylinder, Fig. 43-160.
5. Drive out the shaft holding the selector fork, Fig. 43-161. Note that the shaft can only be driven out in one direction, see Fig.
6. Remove the engaging sleeve and the selector fork, Fig. 43-162.
7. Drive out the output shaft with a plastic mallet. Drive out the seal with 2337, Fig. 43-163.
8. Remove the circlips, Fig. 43-164. for the bearing and press out the bearing with 2267.



VOLVO  
115 401

Fig. 43-161. Driving out shaft



VOLVO  
115 408

Fig. 43-163. Driving out seal

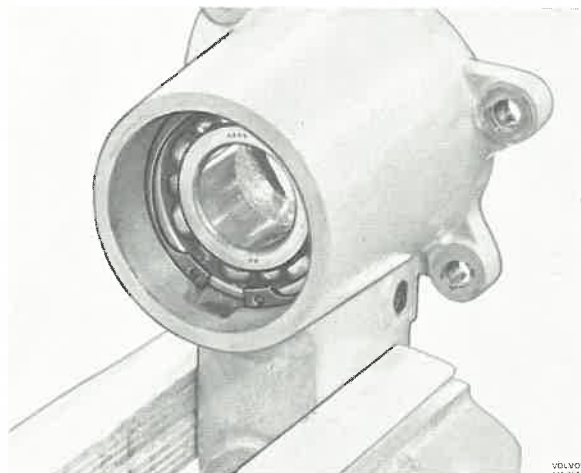


Fig. 43-164. Pressing out bearing

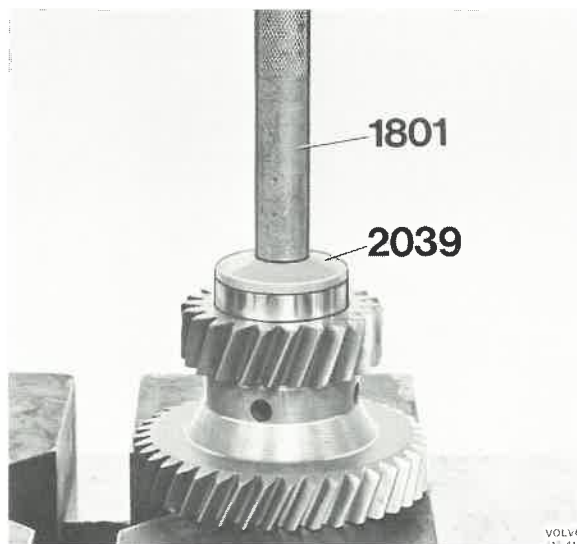


Fig. 43-166. Pressing in outer race

### Checking and replacing parts

Clean all parts and check for damage and wear. All damaged or worn parts should be replaced. Sealing rings, O-rings and gaskets, etc., should always be replaced. When replacing sealing rings, always make sure that the surfaces which perform the sealing are carefully checked. If these are scored or damaged, then the seal in question should be replaced.

### Assembling the auxiliary gearbox

Special tools: 1801, 1845, 2014, 2022, 2039, 2267, 2291, 2395, 2837, 6108, 6109, 6110, 6111, 6120, 6122.

In certain places the auxiliary gearbox has shims of alternative thicknesses as well as circlips in order to obtain correct clearance. Fig. 43-165 a shows where these places are.

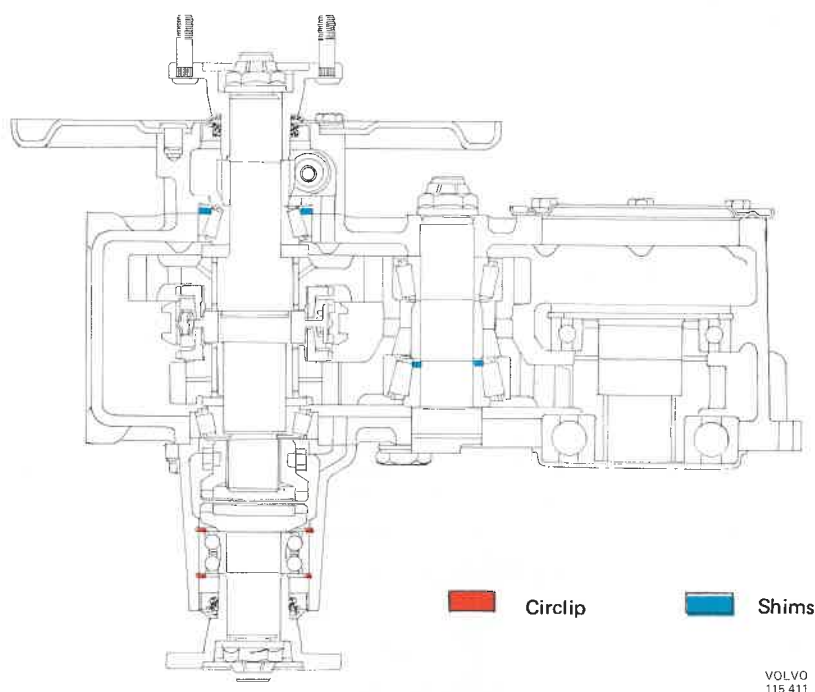


Fig. 43-165. Alternative shims and circlips in auxiliary gearbox

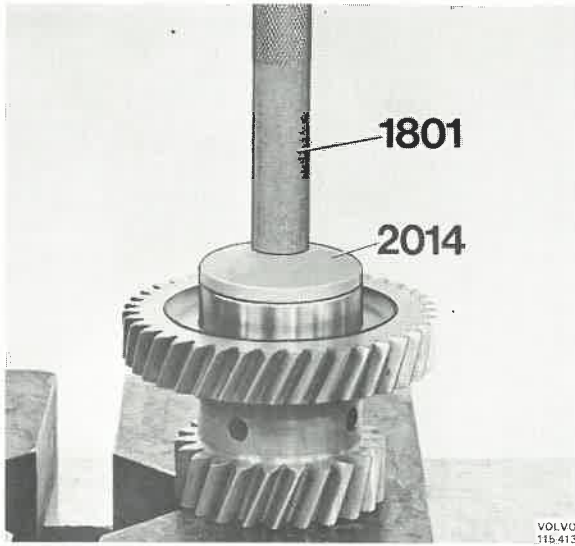


Fig. 43-167. Pressing in outer race

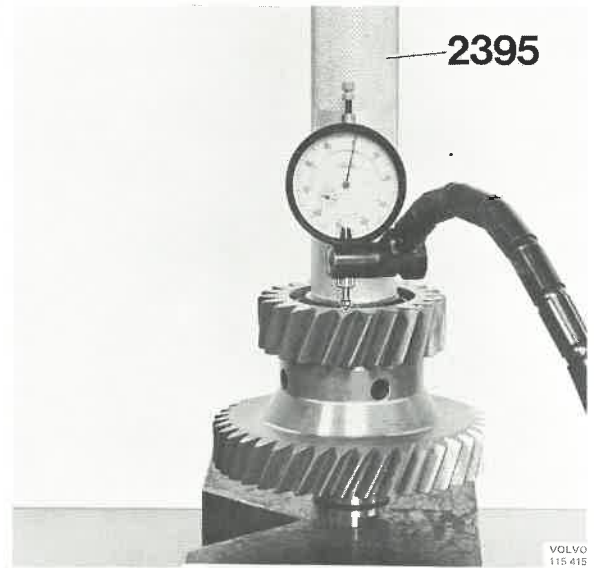


Fig. 43-169. Checking clearance

*Assembling the intermediate gear*

1. Press in the new outer races with 2014 or 2039 + 1801, Figs. 43-166 and 43-167.
2. Place the large bearing on the shaft for the intermediate gear.
3. Place the same number of shims that were removed plus a shim of about 0.2 mm (0.008") on the shaft. Fit spacer sleeve as shown in Fig. 43-168 with the bevelled end upwards.

4. Oil the bearing and fit the intermediate gear and the small bearing (oiled).
5. Place the intermediate gear complete in a press and fit 2395 on the small bearing inner race, Fig. 43-169. Press on the bearing using a force of about 1 ton. Check the axial clearance of the gear with a dial indicator. The clearance should be  $+0.01$  mm ( $+0.0004$ "") to  $+0.06$  mm ( $+0.0024$ ""). Remove the requisite number of shims in order to get the proper clearance.

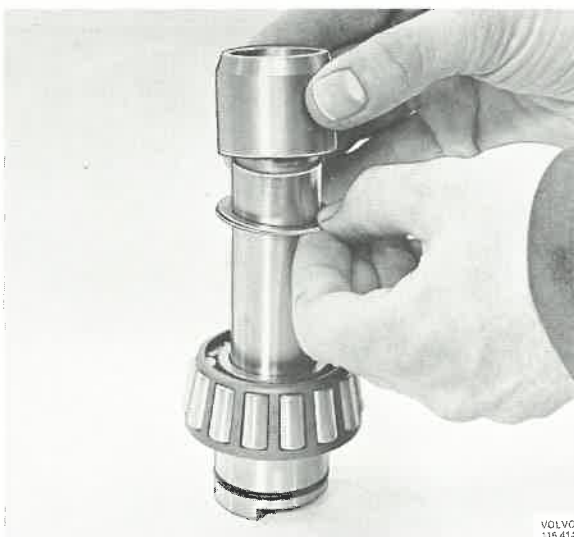


Fig. 43-168. Fitting spacer sleeve



Fig. 43-170. Fitting spacer sleeve



Fig. 43-171. Fitting bearing

6. Place 6120 on a flat base and fit on the large bearing, Fig. 43-170. Fit the requisite number of shims according to point 5 and the spacer sleeve.
7. Fit the intermediate gear and the small bearing, Fig. 43-171.

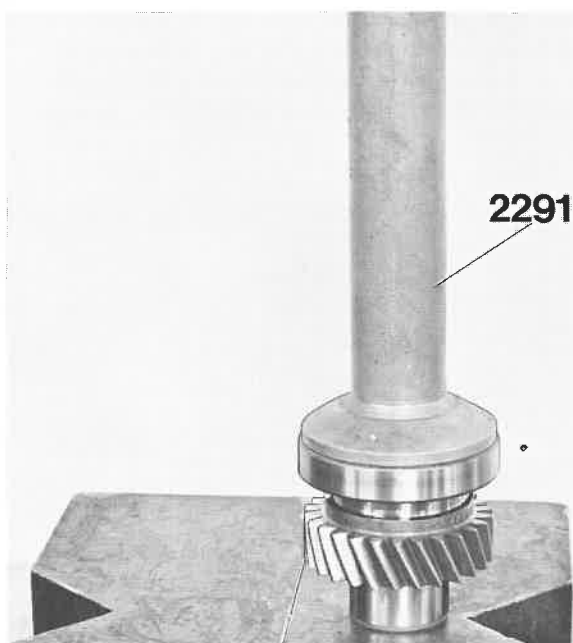


Fig. 43-172. Pressing on bearing

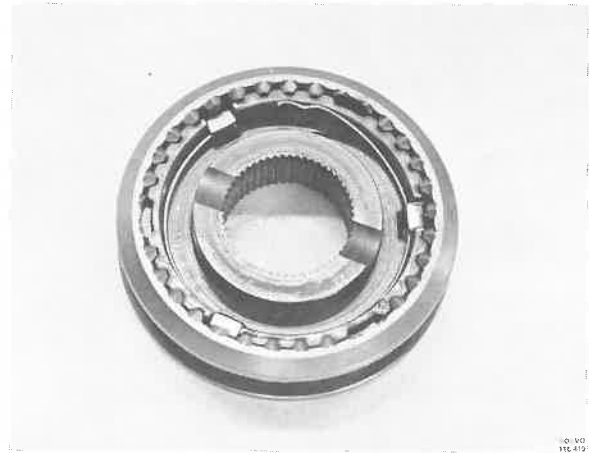


Fig. 43-173. Assembling synchronizing

#### *Assembling the cluster gear*

1. Press the small ball bearing first on the shaft (on the side where the shaft has lands) with 2291, Fig. 43-172.
2. Press on the large ball bearing with 2291.

#### *Assembling the synchronizing*

1. Place the synchronizing hub on a flat base. Fit the engaging sleeve.
2. Fit the interlock units in position and fit the spring, Fig. 43-173.
3. Fit the other spring so that it does not come on the same interlock body, Fig. 43-174.

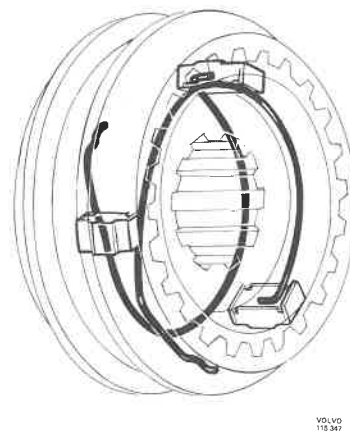


Fig. 43-174. Placing springs

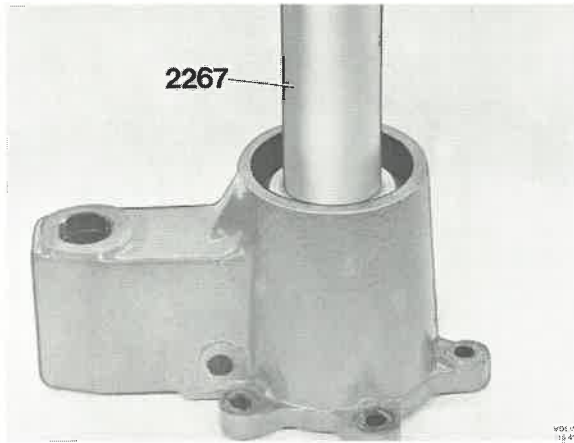


Fig. 43-175. Pressing in bearing

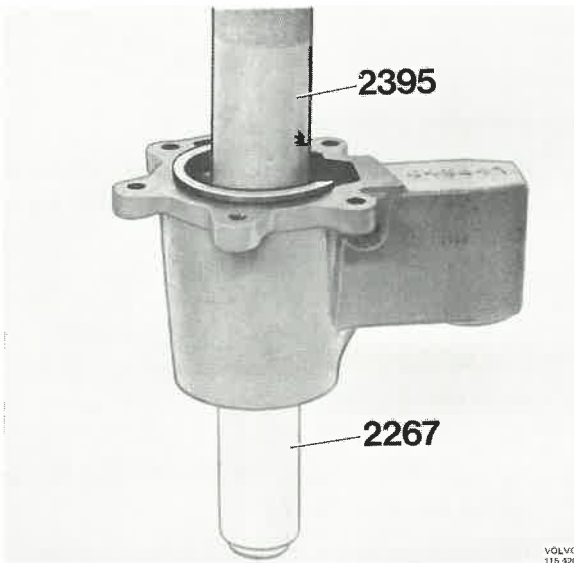


Fig. 43-176. Pressing in output shaft

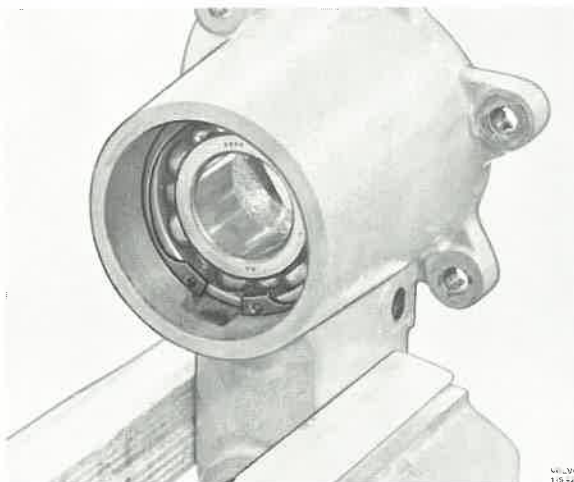


Fig. 43-177. Rear bearings circlip

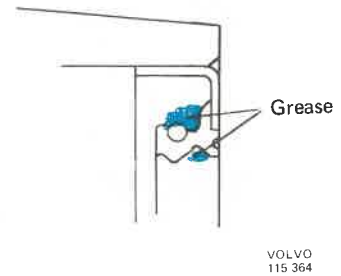


Fig. 43-178. Placing grease

*Assembling the control mechanism*

1. Fit the inner circlip (thickness 2.0 mm = 0.08") in position in the housing. Press in the bearing with 2267, Fig. 43-175.
2. Press in the output shaft. Use 2395 and place 2267 as a counterhold under the bearing, Fig. 43-176.
3. Fit the outer circlip. Circlips are available in thicknesses of 1.9 and 2.0 mm (0.076 and 0.080"), and use the circlip which gives the smallest clearance. Note that the opening of the circlip should be placed at the oil channel in the housing, Fig. 43-177.
4. Coat the contact surface for the seal in the housing with sealing agent.



Fig. 43-179. Pressing in seal

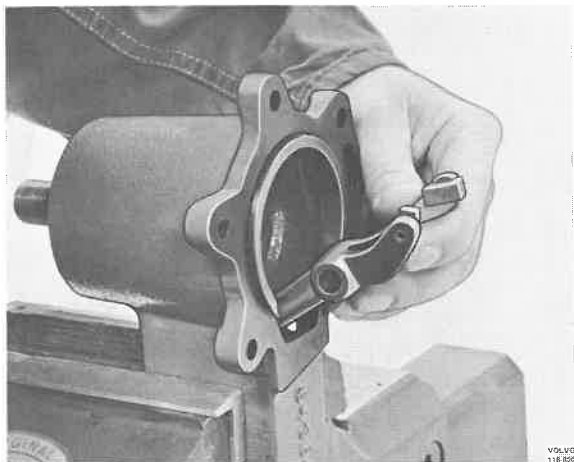


Fig. 43-180. Fitting selector fork

5. Fill about a fourth of the space between the sealing lips and the space between the spring on the reverse side of the sealing lip with grease, Fig. 43-178. Press the seal into the housing with 6108, Fig. 43-179.
6. Secure the control mechanism in a vice. Fig. 43-180.
7. Fit the pins in the selector fork and place the fork and flange in the housing, Fig. 43-181. Coat the shaft holding the selector fork with sealing agent and drive it into the housing.
8. Place the bottom of the control cylinder and the copper washer on the holed nut. Tighten the cylinder to the control mechanism.
9. Fit a new seal on the flange, see Fig. 43-182, and grease the flange wear surface.
10. Pull on the flange with 1845, see Fig. 43-183. Remove 1845 and fit counterhold 2837, see Fig. 43-184. Fit the flange nut and tighten it to a torque of 100-120 Nm (10-12 kpm = 72-87 lbftf).

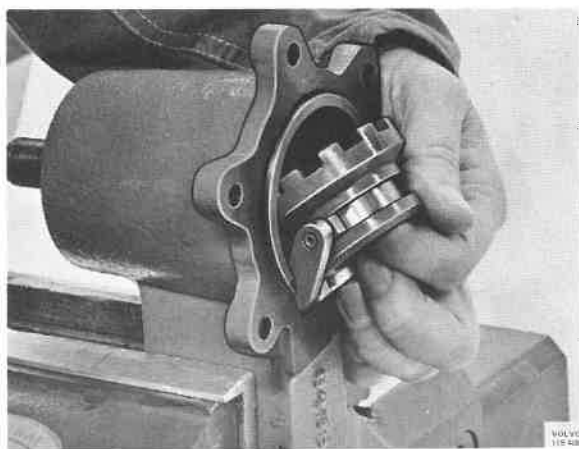


Fig. 43-181. Fitting flange



Fig. 43-182. Flange seal

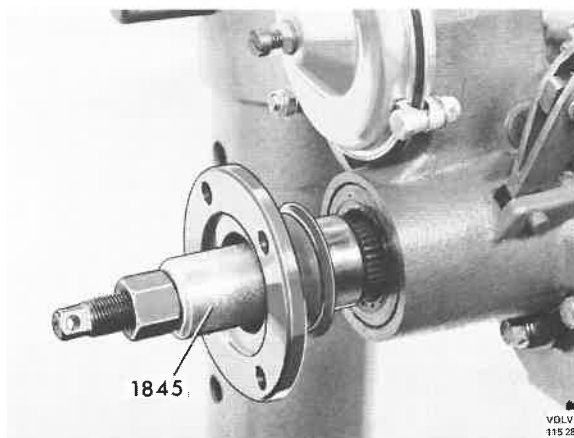


Fig. 43-183. Pressing on flange

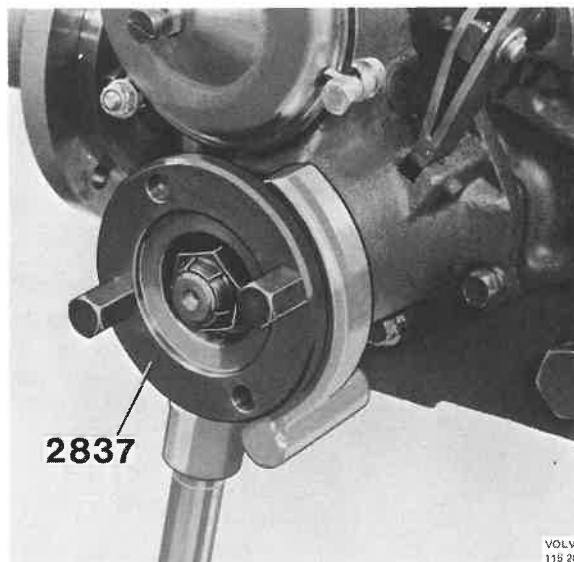


Fig. 43-184. Fitting counterhold



Fig. 43-185. Pressing on bearing

*Assembling other parts on auxiliary gearbox*

1. Place drift 6111 in plate 6109 and place them on the press table. Press the inner race and washer on the output shaft, Fig. 43-185. Fit the circlip for the cluster gear bearing in the housing. The circlip should be fitted with the dished side facing the bearing. Place the auxiliary gearbox in a press with the rear end resting against the press table. Press in the cluster gear with 2291, Fig. 43-186. Note that the bearing

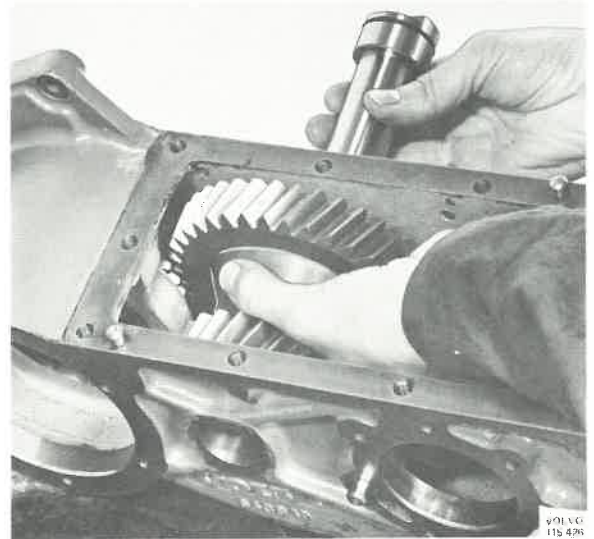


Fig. 43-187. Fitting intermediate gear shaft

will lie about 8 mm (5/16") outside the face of the housing before the circlip is inserted.

2. Place the intermediate gear in the auxiliary gearbox, fit a new O-ring on the intermediate gear shaft and screw it tight in the guide sleeve, Fig. 43-187. Press in the shaft and remove the sleeve, Fig. 43-188.
3. Turn the auxiliary gearbox and fit a new O-ring on the shaft. Fit the washer and nut.
4. Oil the needle bearing for the output shaft low-speed gear and place it on the gear. Place the synchronizing unit with gears in the auxiliary gearbox, Fig. 43-189.

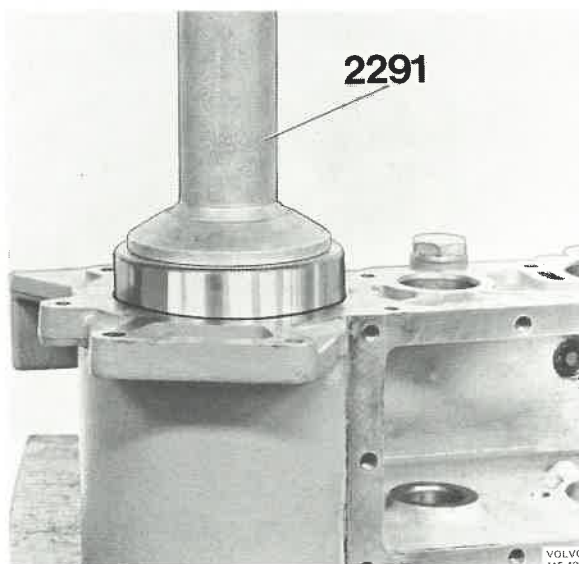


Fig. 43-186. Pressing in cluster gear

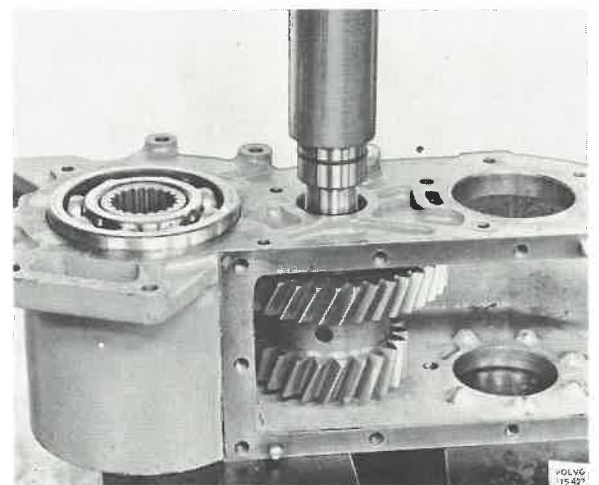


Fig. 43-188. Pressing in intermediate gear shaft

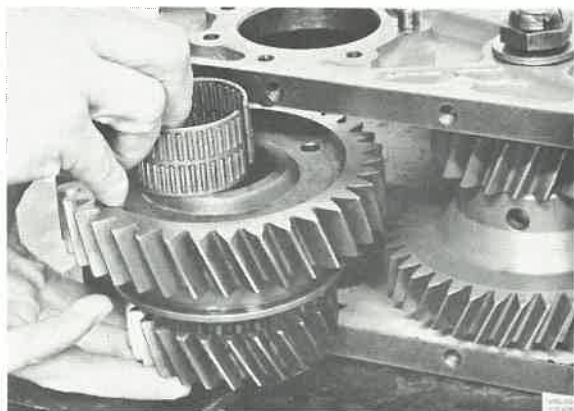


Fig. 43-189. Placing gears in aux. gearbox

5. Fit the drift 6110 in the plate 6109 and place them on the press table. Place the auxiliary gearbox on the drift, with the synchronizing hub resting against the drift, Fig. 43-190. Support under the box so that it is horizontal.
6. Fit the output shaft, rotate the shaft so that the lands on the shaft enter the hub. Press in the shaft, Fig. 43-191.
7. Remove the auxiliary gearbox. Replace the drift with 6111 and fit the ring 6122 on the drift. Turn the auxiliary gearbox and place it on the drift with ring 6122 resting against the rear bearing inner race, Fig. 43-192. Support under the auxiliary gearbox.
8. Check to make sure the synchronizing cone for the high speed is properly fitted in the hub. Fit the needle bearing inner race on the shaft and press it in with 6110, Fig. 43-193. Oil the

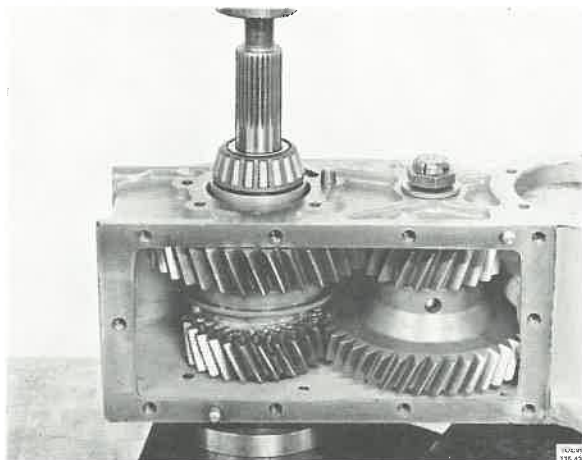


Fig. 43-191. Pressing in output shaft

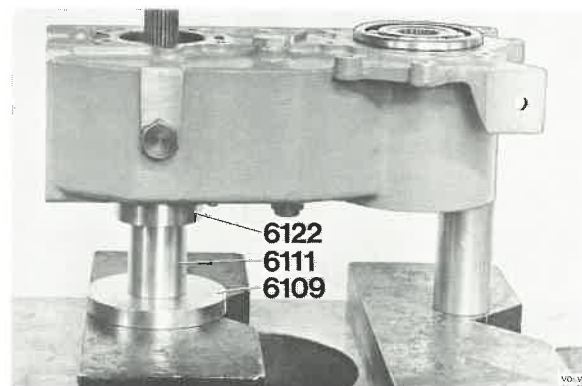


Fig. 43-192. Placing aux. gearbox

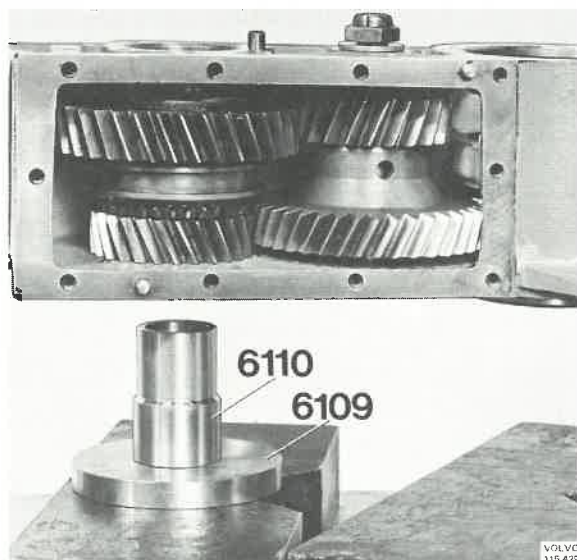


Fig. 43-190. Placing aux. gearbox on counterhold

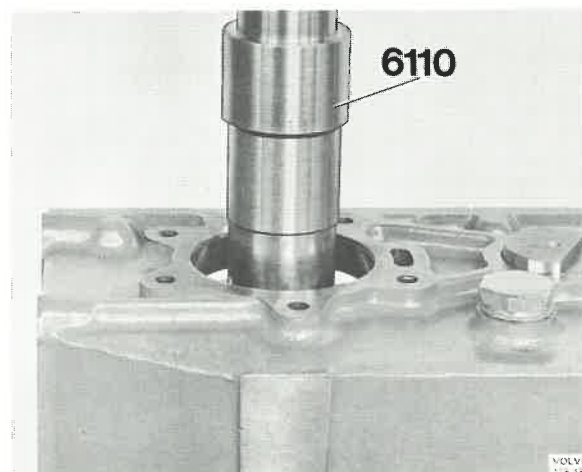


Fig. 43-193. Pressing on inner race

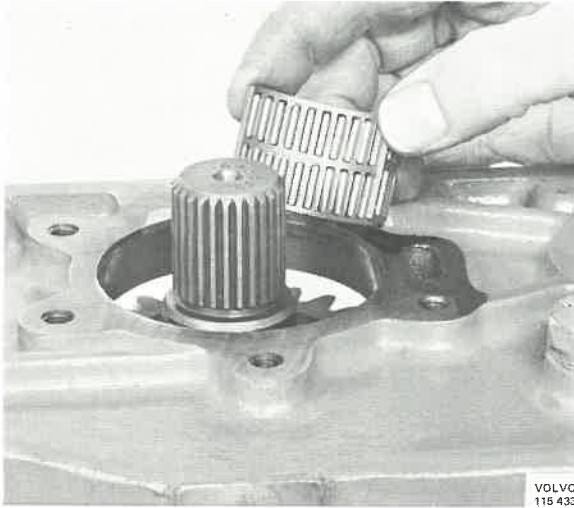


Fig. 43-194. Fitting needle bearings

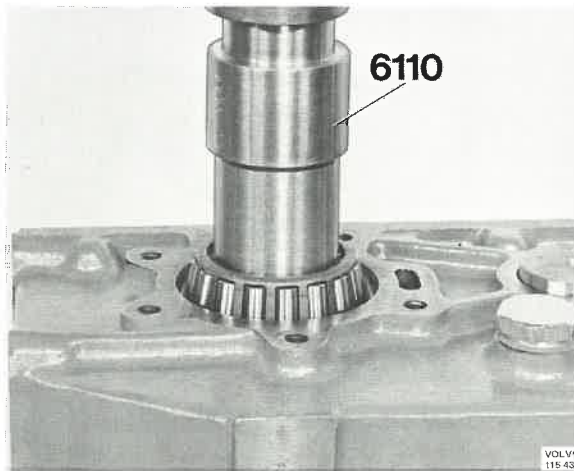


Fig. 43-195. Pressing on inner race

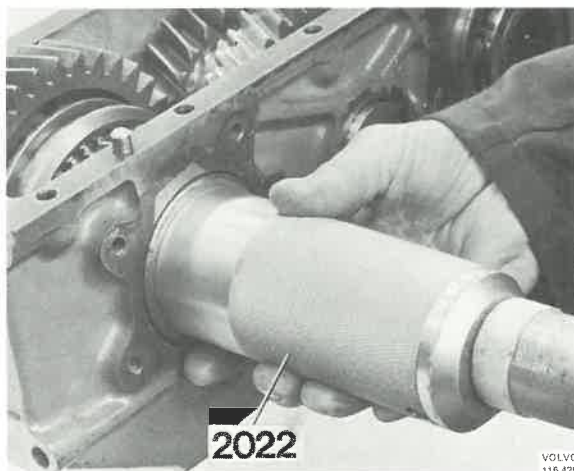


Fig. 43-196. Driving in outer race

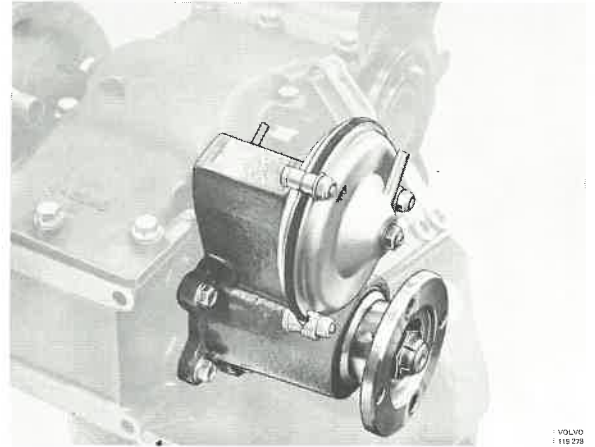


Fig. 43-197. Fitting control mechanism

- needle bearings and fit them in position, Fig. 43-194.
9. Fit the axial washer and the front bearing inner race on the shaft, with the inner bevel of the washer facing upwards. Press them on with 6110, Fig. 43-195.  
Fix the auxiliary gearbox in fixture 6140.
  10. Drive in the outer race for the output shaft front bearing with 2022, Fig. 43-196. The race should lie about 2 mm (0.08") on the inside of the housing.
  11. Coat the control mechanism contact surface with sealing agent and fit it securely in the auxiliary gearbox, see Fig. 43-197. Tighten the bolts to a torque of 20-25 Nm (2.0-2.5 kpm = 14-18 lbftf).  
The engagement of the control mechanism should always be checked. See under "Adjusting the control mechanism".

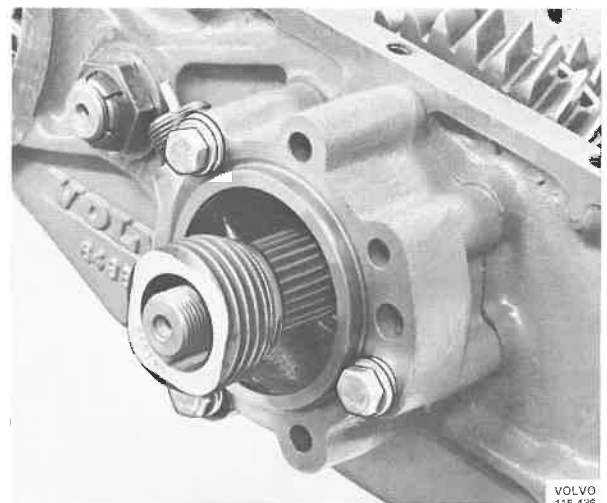


Fig. 43-198. Fitting rear housing half



Fig. 43-199. Flange seal

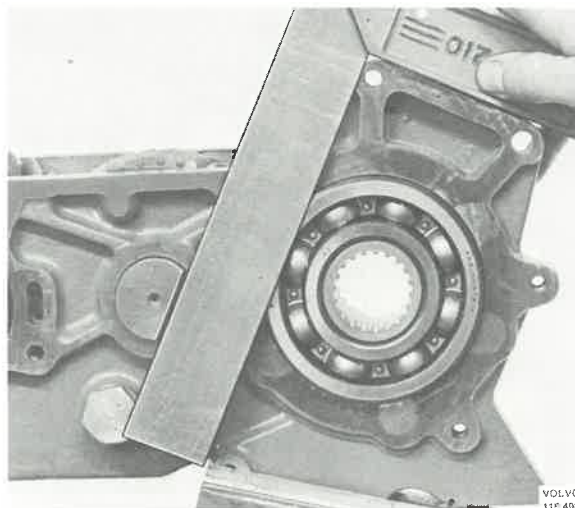


Fig. 43-201. Adjusting shaft

12. Place shims in the rear housing (use those shims removed during disassembling less one shim). Place the outer race in the housing. Fix the housing in position with the three bolts, using double washers under the bolts, Fig. 43-198.
13. Fit the speedometer pinion with the tapered part facing the rear bearing, Fig. 43-198. Fit a new seal on the flange, Fig. 43-199. Pull on the flange with 1845, Fig. 43-200. Coat the sealing lip with grease. Remove the press tool and tighten up the nut. Tighten the nut to a torque of 100–120 Nm (10–12 kpm = 72–87 lbftf).
14. Remove the auxiliary gearbox from the press and place it in a vice. Rotate the intermediate gear shaft so that the stop lug is at an angle of about 90° in relation to the connection face against the

gearbox, Fig. 43-201. Tighten the nut for the shaft to a torque of 100–120 Nm (10–12 kpm = 72–87 lbftf).

Rotate the output shaft. Check the shaft's axial clearance with a dial indicator, Fig. 43-202. Place the point of the indicator against the shaft pin. The axial clearance may be  $+0.08$  (+0.0032")  $+0.03$  mm. (+0.0012"). The difference between the obtained and permitted measurement is the measurement for the number of shims requires. Shims are available in the following sizes: 0.1, 0.15, 0.35 and 0.50 mm (0.004, 0.006, 0.014 and 0.020").

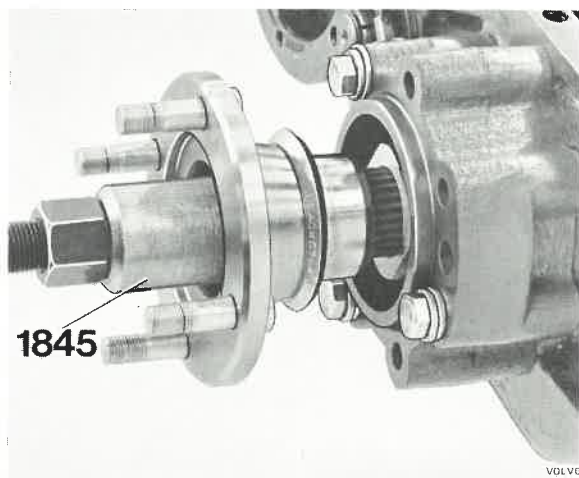


Fig. 43-200. Pressing on flange

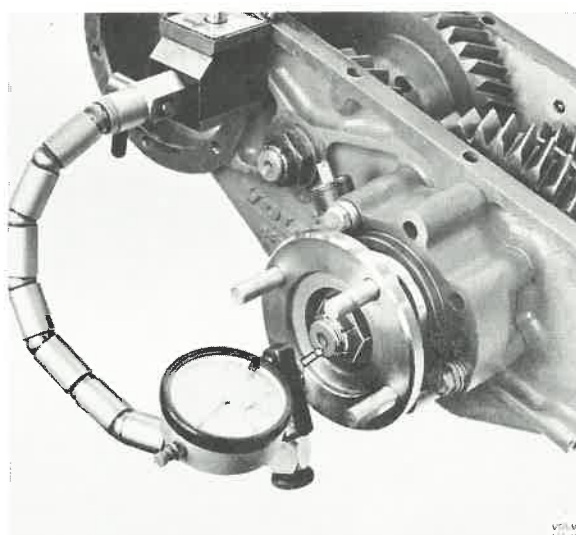


Fig. 43-202. Checking axial clearance

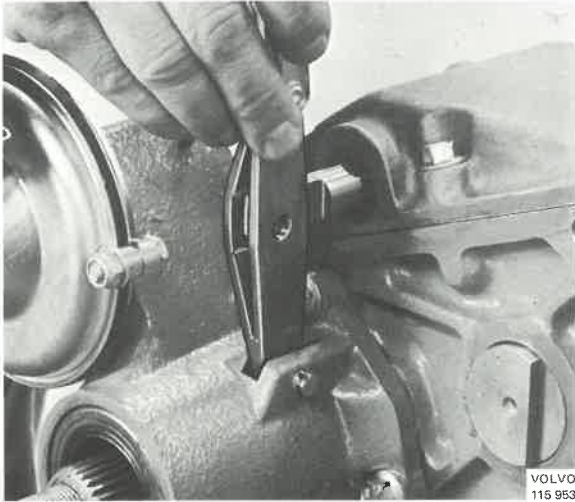


Fig. 43-203. Placing the lever

16. Remove the indicator and remove the rear flange with 2261. Remove the rear cover and the shims. If the lever has been removed, fit it according to Fig. 43-203.
- 17 Coat the sealing ring seat in the rear housing with sealing agent. Fill 1/4 of the space between the seal lips with grease, Fig. 43-204. Fit the seal on drift 6108 and drive the seal into the housing, Fig. 43-205. Remove the drift and grease the seal slide surfaces.
- 18 Coat the contact surface of the housing with sealing agent. Place the correct number of shims according to point 15 in the housing and fix the housing on the auxiliary gearbox.
19. Fit the backing plate for the propeller shaft brake. Fit a new seal on the flange and grease it. Pull on the flange and fit the nut and tighten it to a torque of 280-300 Nm (28-30 kmp = 202-217 lbftf).

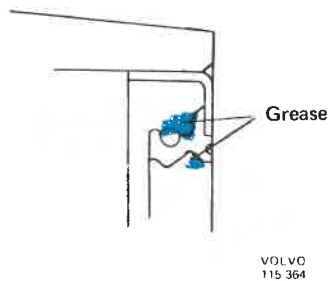


Fig. 43-204. Placing grease



Fig. 43-205. Driving in seal

20. Coat the contact surface on the selector shaft with sealing agent and fix the shaft on the auxiliary gearbox.

#### Adjusting the control mechanism

When adjusting the control mechanism the cover as well as the washer and diaphragm must be removed from the control cylinder.

1. Pull the pull rod so that the flange is in full mesh with the output shaft. Screw in the pull rod nut so that it is a bit on the inside of the holded nut. Fit the inner washer for the diaphragm on the rod. Press the washer against the holed nut. When the pull rod is pulled back and forth there should

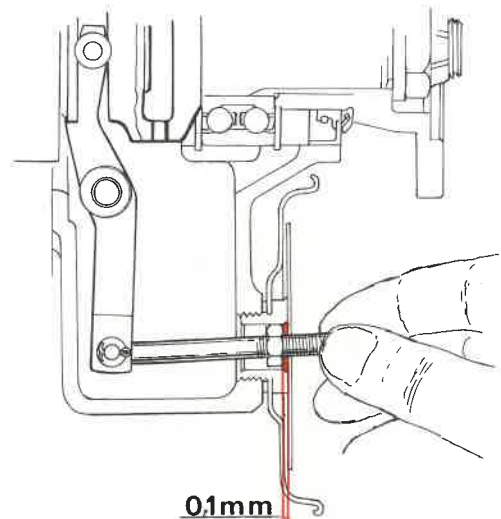


Fig. 43-206. Checking clearance

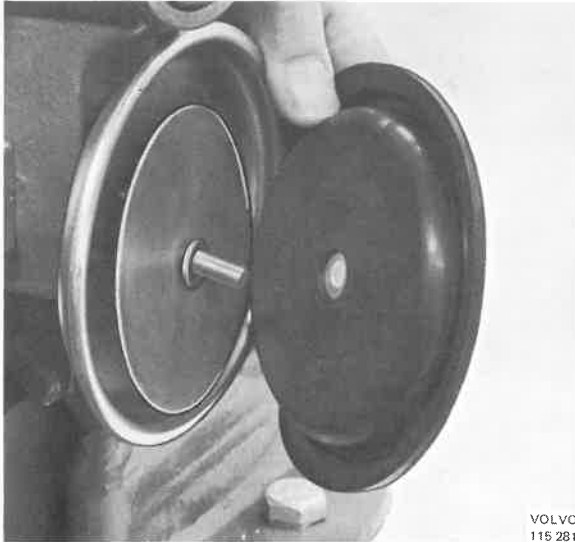


Fig. 43-207. Fitting diaphragm

be a clearance of about 0.1 mm (0.004"). If necessary, adjust so that the correct clearance is obtained, Fig. 43-206.

2. Fit the diaphragm and place the spacer washer in the centre of the diaphragm, Fig. 43-207. Fit on the outer washer and the lock nut. Hold the diaphragm and washer when tightening up the nut.
3. Fit the thrust spring, Fig. 43-208, and the cover. Fit the clamp bolts for the cover and make sure that they are distributed evenly round the cover.
4. Release the lock nut securing the bolt in the cover, Fig. 43-209. Screw the bolt to the bottom. Unscrew the bolt  $5 \frac{3}{10}$  turns (approx. 8 mm = 0.32") Tighten up the lock nut.

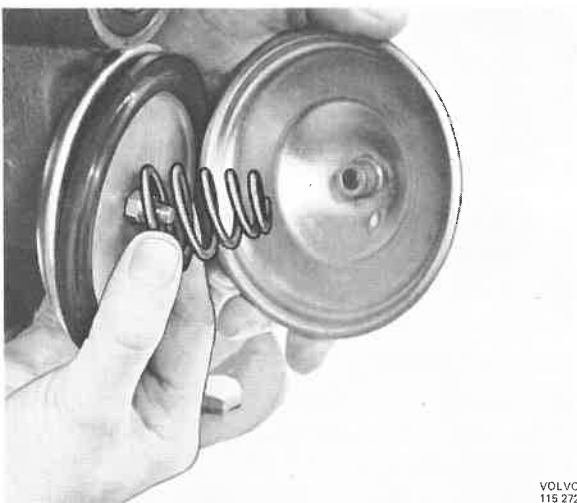
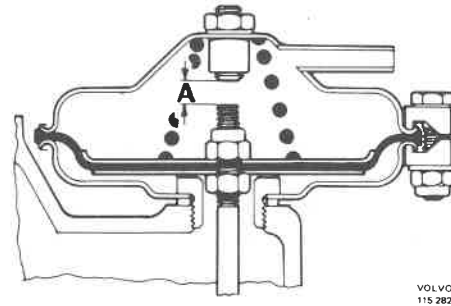


Fig. 43-208. Fitting spring and cover



A =  $5 \frac{3}{10}$  turns (8 mm)

Fig. 43-209. Screw in cover

### Installing the auxiliary gearbox

Special tools: 2837, 6128, 6136

1. Place the auxiliary gearbox on the gearbox jack, Fig. 43-210. Check that the sleeve for the gearbox output shaft can easily be pushed back and forth in the auxiliary gearbox gear cluster. If the sleeve is stiff, the lands must be ground with carborundum. Remove the sleeve.
2. Push the auxiliary gearbox on the jack in under the vehicle. Coat the surface of the auxiliary gearbox which is in contact with the standard gearbox with sealing agent. Jack up and fit the auxiliary gearbox to the gearbox. Fit the nuts round the auxiliary gearbox connection flange.

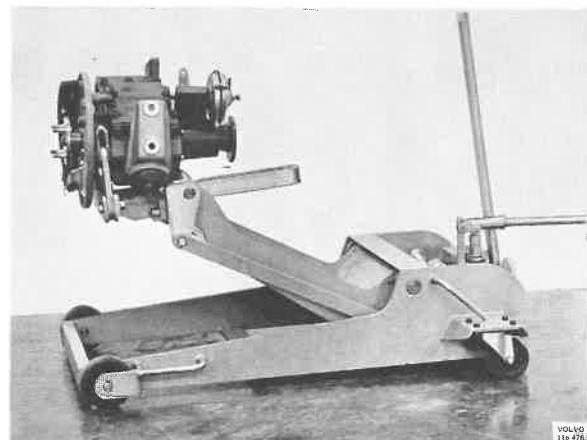


Fig. 43-210. Gearbox placed on jack

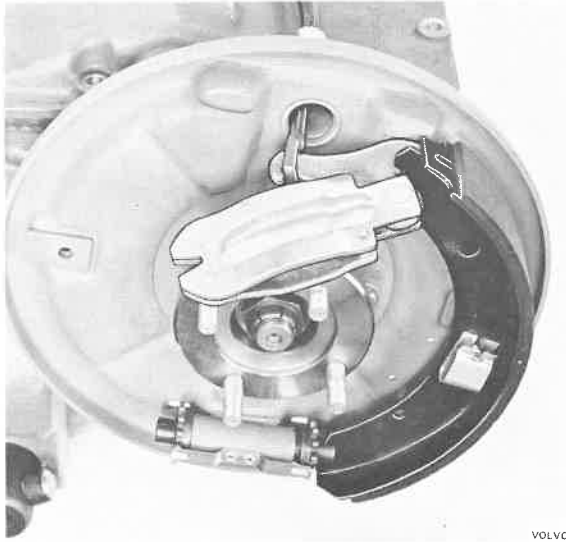


Fig. 43-211. Fitting the brakeshoe

3. Fit the sleeve. Rotate the output shaft on the auxiliary gearbox while pushing in the sleeve at the same time. Engage low gear. Engage front wheel drive. Fit and tighten up the nut to a torque of 280–300 Nm (28–30 kpm = 202–217 lbftf). If necessary use 2837 on the control mechanism flange.
4. Coat the contact surface of the cover with sealing agent. Screw tight the cover. Fit the parking brake wire in position.
5. Fit the bolts for the rear engine mounts. Remove the jack.

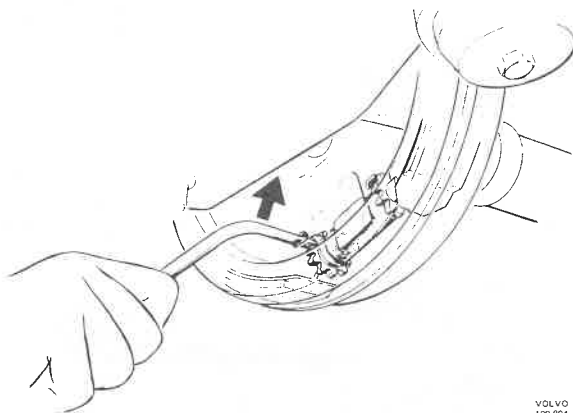


Fig. 43-212. Adjusting brake shoes

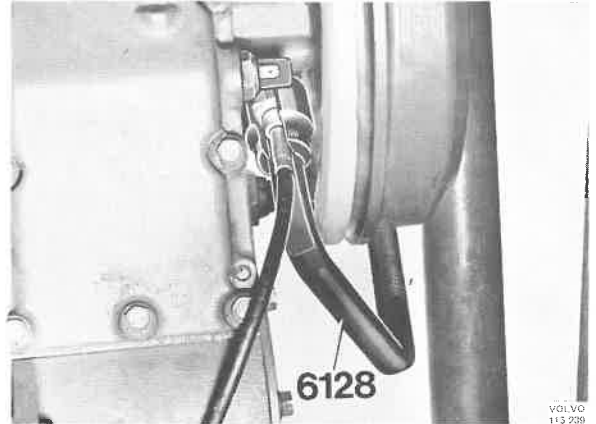


Fig. 43-213. Fitting speedometer wire

6. Assemble the propeller shaft brake. First fit the lower brake shoe. Then the lever (Fig. 43-211), the upper return spring, the upper shoe, the lower return spring and the drum.
7. Adjust out one of the brake shoes with a screwdriver, Fig. 43-212, until it is just possible to rotate the drum. The drum should be fixed with nuts. Slacken the adjuster screw until the drum rotates freely, but max. 5 teeth. Adjust the other brake shoe in the same way.
8. Check the movement of the parking brake lever. If the parking brake does not give full brake application at the 4th–5th ratchet, in spite of the fact that the propeller shaft brake has been properly adjusted, alter the length of the wire with the nut at its front end.
9. Fit the front and rear propeller shafts and tighten the bolts to a torque of 55–65 Nm (5,5–6,5 kpm = 40–47 lbftf). Fit the exhaust manifold. Fill the auxiliary gearbox with oil. Concerning quantity and quality, see under "Data".
10. Remove the hoist eyelet and tighten the cylinder head bolts to a torque of 90 Nm (9 kpm = 66.4 lbftf).
11. Screw tight the speedometer wire with 6128, Fig. 43-213.
12. Fit and connect up the evacuation and vacuum hoses to the control mechanism. Fit and connect up the cable to the sender.
13. Place the lever on the gearbox selector shaft housing and auxiliary gearbox in neutral. The hole in the gearbox lever and the link should coincide in order to make it easier to fit the lock pin, see Fig. 43-214. If necessary, adjust the link fork.

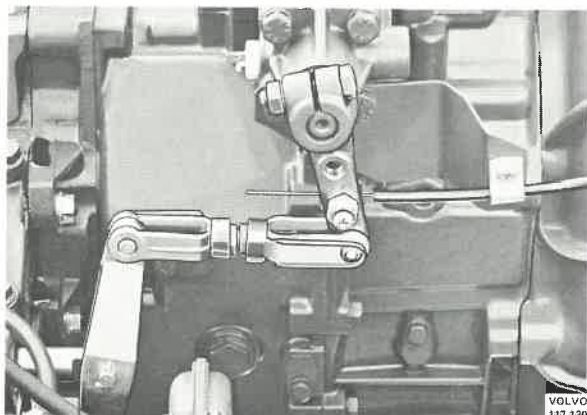
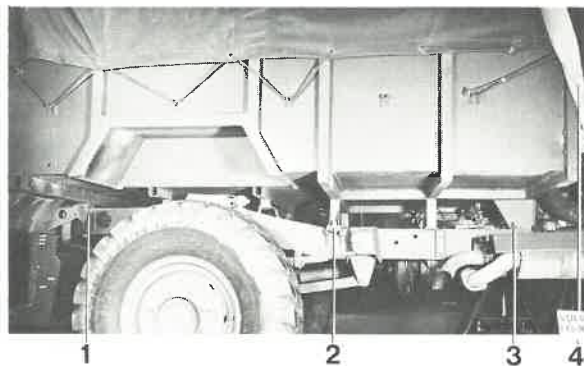


Fig. 43-214. Place the lever



- |            |                 |
|------------|-----------------|
| 1. Bolting | 3. U-bolts      |
| 2. Bolting | 4. Hoist straps |

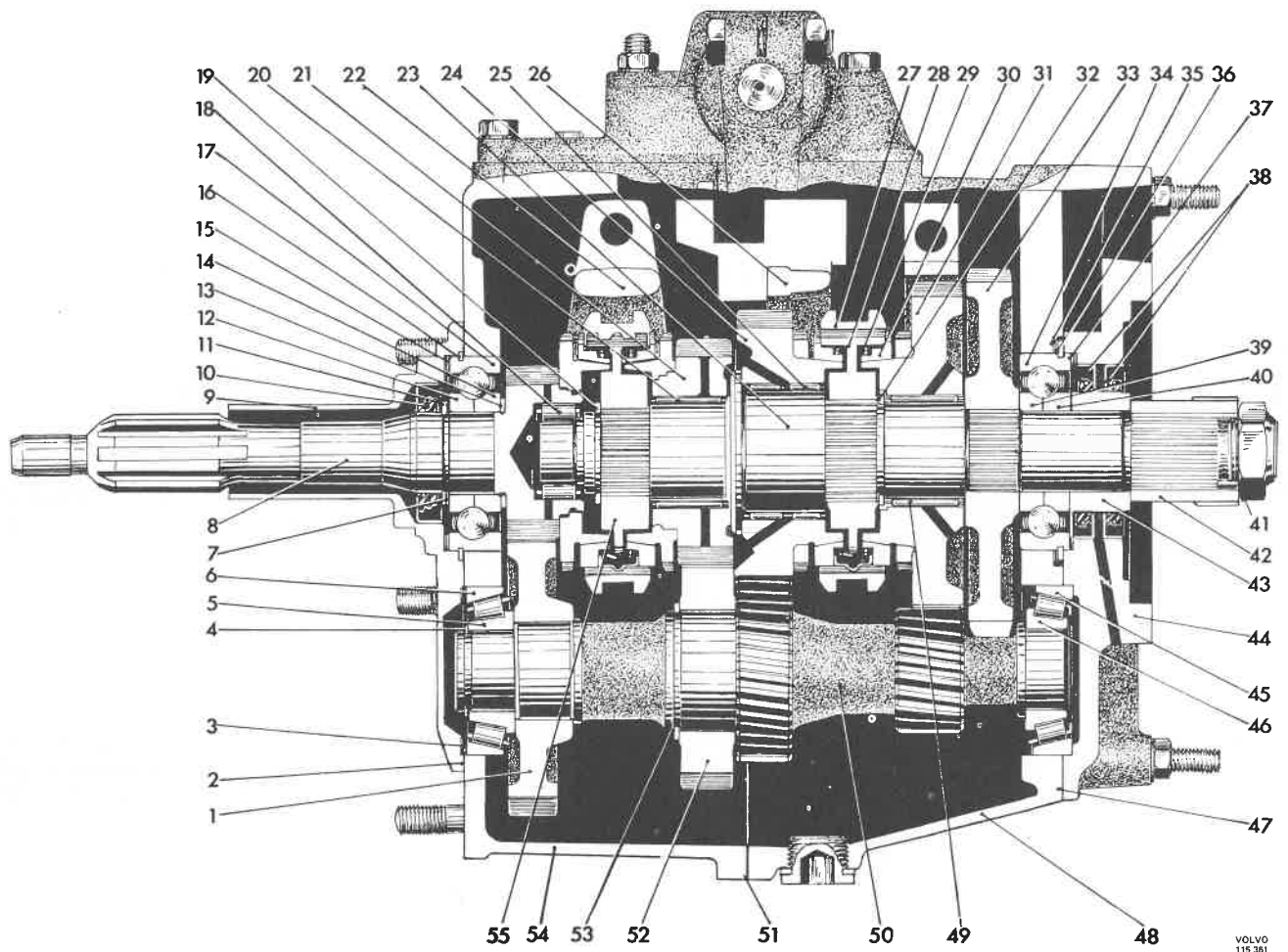
Fig. 43-215 Fitting the platform

14. Place the wire for the indicator in the gear shaft housing. Turn the indicator arrow to the zero position. Fix the wire to the gear shaft lever, see Fig. 43-214.
15. Place the platform in position, see Fig. 43-215, and tighten up the bolts and U-bolts.
16. Connect the earth connection to the battery and fit the cover.

**Illustration 43-A Gearbox**

**Gearbox**

1. Gear
2. Gasket
3. Shim
4. Circlip
5. Inner race
6. Outer race
7. Shim
8. Input shaft
9. Sleeve
10. Seal
11. Circlip
12. Inner ring
13. Shim
14. Inner ring
15. Shim
16. Circlip
17. Ball bearing
18. Roller bearing
19. Circlip
20. Needle bearing
21. Gear, 3rd
22. Selector fork, 3rd-4th
23. Output shaft
24. Gear, 2nd
25. Needle bearing
26. Selector fork, 1st-2nd
27. Engaging sleeve, 1st-2nd
28. Hub, 1st-2nd
29. Spring
30. Cone
31. Gear, 1st
32. Circlip
33. Reverse gear
34. Ball bearing
35. Shim
36. Circlip
37. Shim
38. Seals
39. Inner race
40. Inner race
41. Nut
42. Gear
43. Wear ring
44. Rear cover
45. Outer race
46. Inner race
47. Gasket
48. Inner housing
49. Needle bearing
50. Intermediate shaft
51. Gasket
52. 3rd gear
53. Circlip
54. Outer housing
55. Hub, 3rd-4th



**Illustration 43-B. Gearbox**

**Gearbox**

1. Dowel
2. Selector fork, 3rd-4th
3. O-ring
4. Bearing pin, 3rd-4th
5. Washer
6. Bolt
7. Gear shift bar
8. Circlip
9. Gear shift bar
10. Shift fork, 1st-2nd
11. Bearing pin, 1st-2nd
12. Lever
13. Circlip
14. Washer
15. Seal
16. Bushing
17. Tubular pin
18. Shift fork, reverse
19. Bearing pin, reverse
20. Case
21. Seal
22. Seal
23. Bushing
24. Seal
25. Bushing
26. Inhibitor
27. Gasket
28. Selector shaft housing
29. Selector shaft
30. Inhibitor shaft
31. Spacer tube
32. Spring
33. Washer
34. Spacer tube
35. Spring
36. Washer
37. Circlip
38. Circlip
39. Pin
40. Selector shaft
41. Outer selector shaft housing
42. Reverse light contact
43. Sealing ring
44. Plug
45. Housing, outer
46. Ball
47. Spring
48. Pin
49. Seal
50. Rear cover
51. Seal
52. Shim
53. Gasket
54. Housing, inner
55. Bolt
56. Washer
57. Cover
58. Gasket
59. Plug
60. Washer
61. Gasket
62. Inhex bolt

7

6

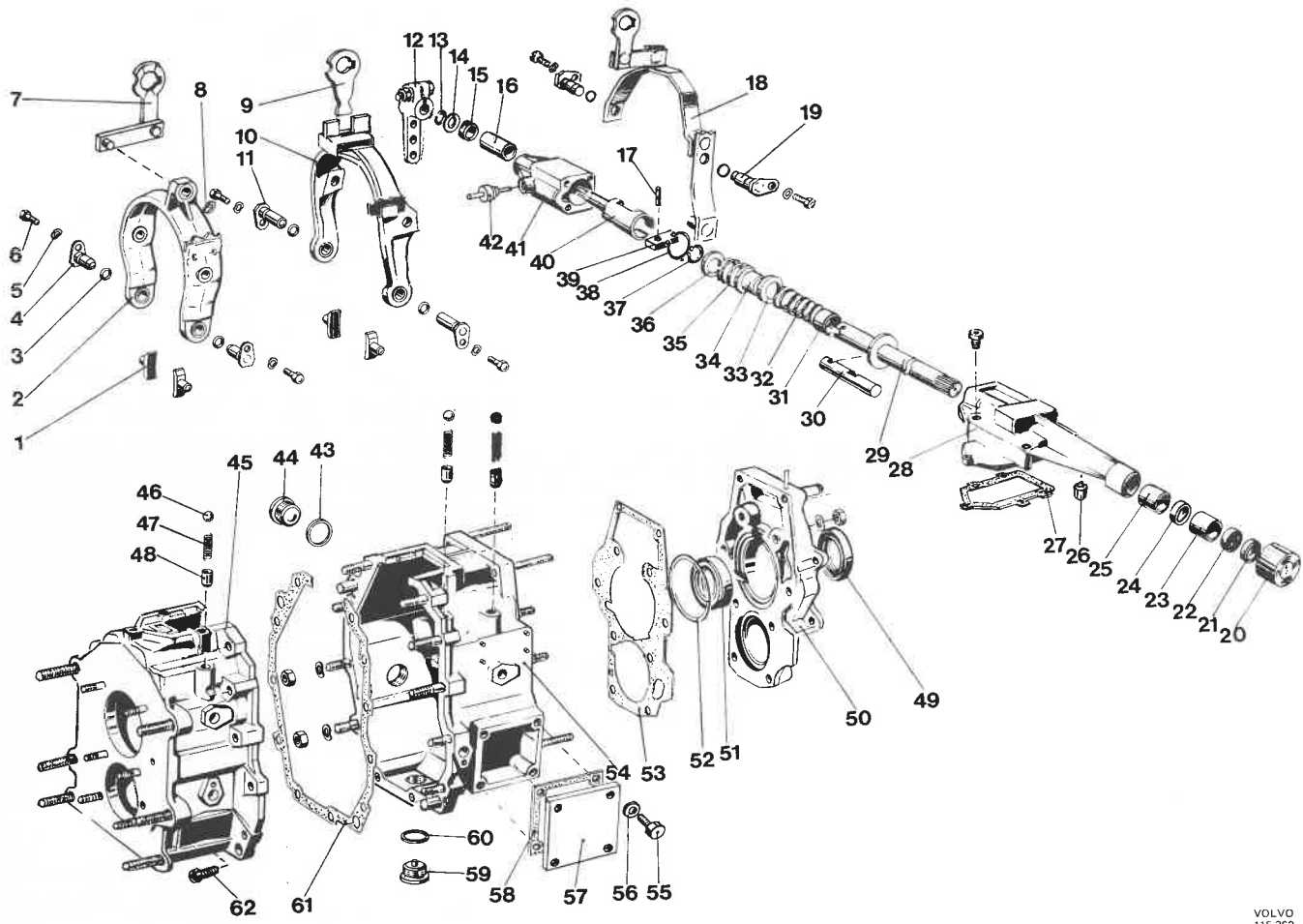
5

4

3

2

1



**Illustration 43-C.Gearbox**

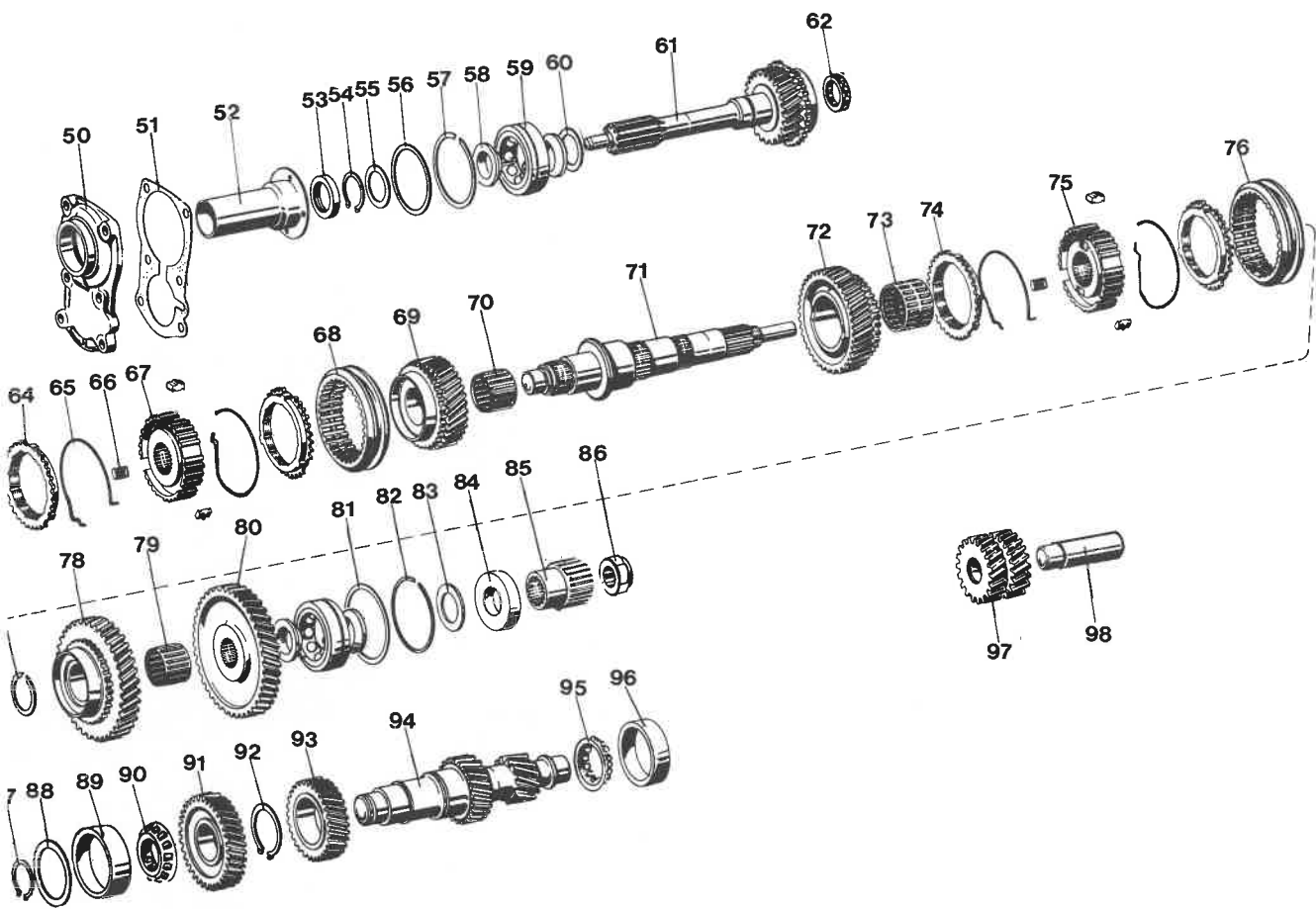
**Gearbox**

- 50. Front cover
- 51. Gasket
- 52. Sleeve
- 53. Seal
- 54. Circlip
- 55. Shim
- 56. Shim
- 57. Circlip
- 58. Inner ring
- 59. Bearing
- 60. Shim
- 61. Input shaft
- 62. Roller bearing
- 63. Circlip
- 64. Synchronizing cone
- 65. Spring
- 66. Inhibitor
- 67. Hub
- 68. Engaging sleeve
- 69. 3rd gear
- 70. Needle bearing
- 71. Output shaft
- 72. 2nd gear
- 73. Needle bearing
- 74. Cone
- 75. Hub
- 76. Engaging sleeve
- 77. Lock ring
- 78. 1st gear
- 79. Needle bearing
- 80. Reverse
- 81. Shim
- 82. Circlip
- 83. Shim
- 84. Wear ring
- 85. Drive
- 86. Nut
- 87. Circlip
- 88. Shim
- 89. Outer ring
- 90. Bearing
- 91. Drive gear
- 92. Circlip
- 93. 3rd gear
- 94. Intermediate shaft
- 95. Bearing
- 96. Outer ring
- 97. Gear
- 98. Reverse shaft

63 6

77

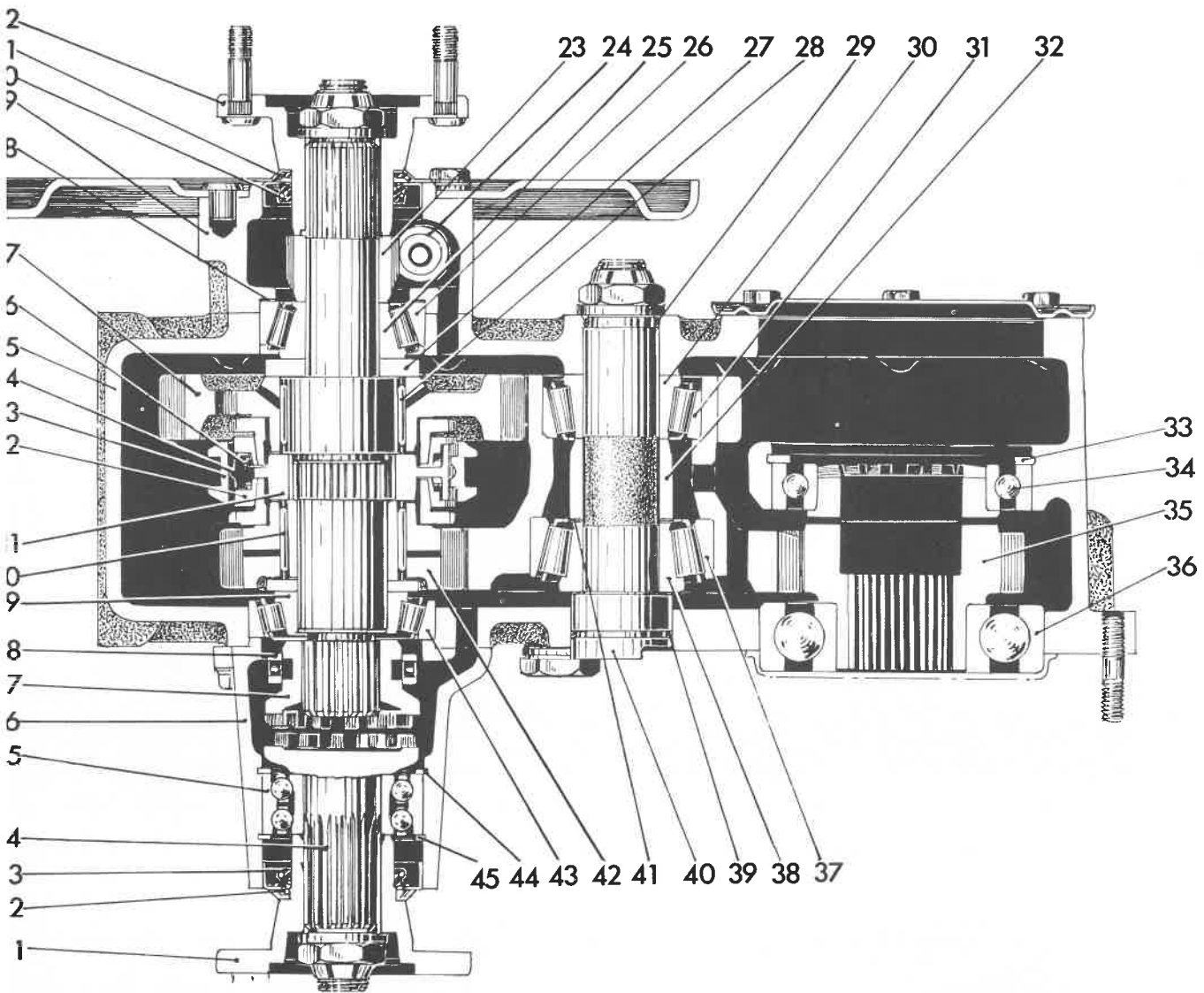
87



**Illustration 43-D. Auxiliary gearbox**

**Auxiliary gearbox**

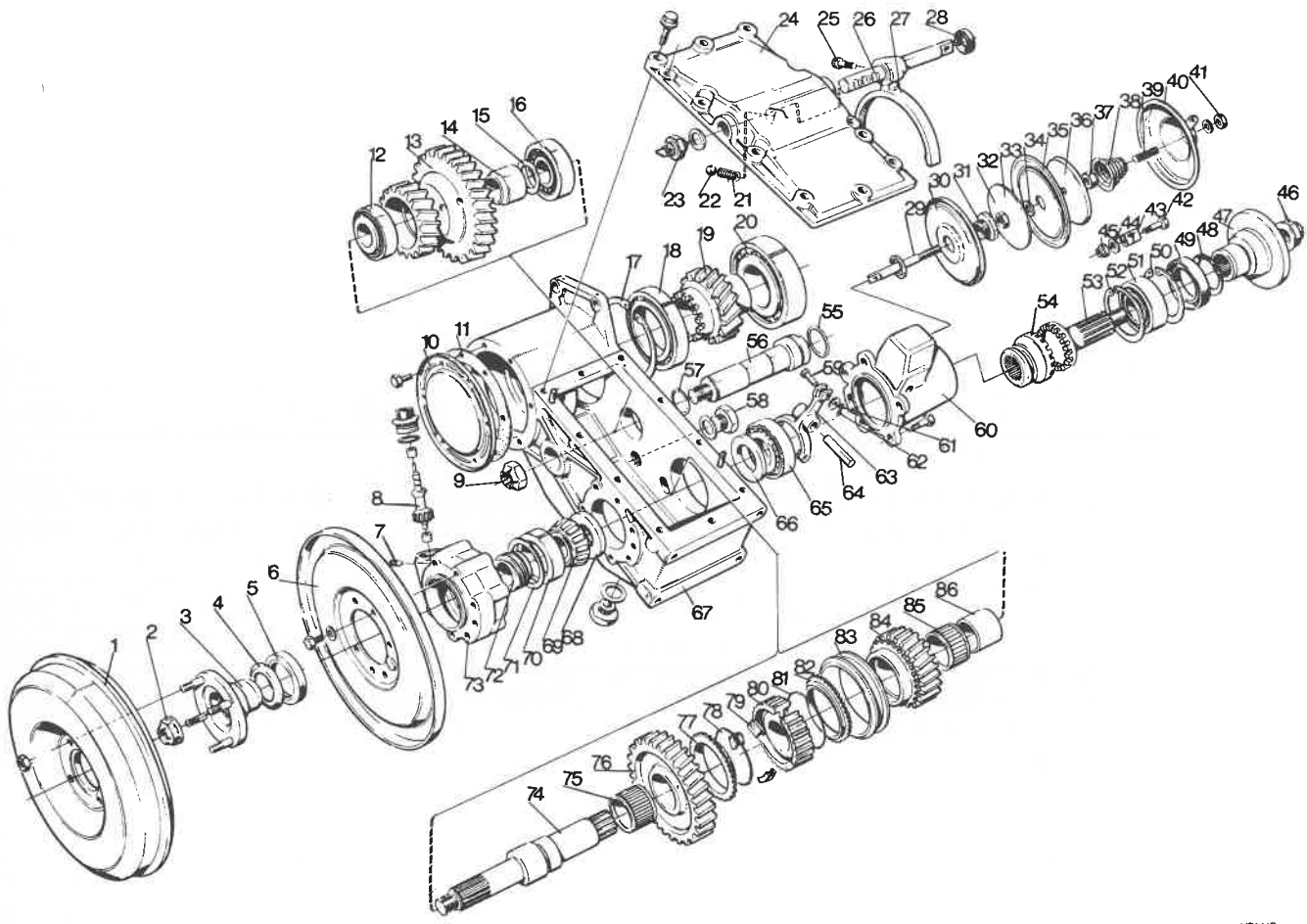
1. Flange	22
2. Flange seal	21
3. Seal	20
4. Output shaft	19
5. Ball bearing	
6. Housing	
7. Flange	18
8. Shift fork	
9. Roller bearing, inner race	
10. Needle bearing	
11. Hub	
12. Cone	17
13. Engaging sleeve	
14. Inhibitor	16
15. Housing	
16. Spring	15
17. Gear, low-speed	14
18. Shims	13
19. Housing	12
20. Seal	
21. Flange seal	
22. Flange	
23. Speedometer gear	
24. Speedometer spindle	11
25. Roller bearing, inner race	10
26. Roller bearing, outer race	9
27. Washer	
28. Needle bearing	
29. O-ring	8
30. Roller bearing, inner race	7
31. Roller, bearing outer race	
32. Spacer washer	6
33. Circlip	5
34. Ball bearing	
35. Drive gear	
36. Ball bearing	
37. Roller bearing, inner race	4
38. Roller bearing, inner race	3
39. O-ring	2
40. Shaft	
41. Shims	1
42. Gear, high-speed	
43. Roller bearing, outer race	
44. Circlip	
45. Circlip	



**Illustration 43-E. Auxiliary gearbox**

**Auxiliary gearbox**

- |                        |                      |
|------------------------|----------------------|
| 1. Brake drum          | 44. Washer           |
| 2. Nut                 | 45. Nut              |
| 3. Flange              | 46. Nut              |
| 4. Flange seal         | 47. Flange           |
| 5. Seal                | 48. Flange seal      |
| 6. Shield              | 49. Seal             |
| 7. Stop screw          | 50. Circlip          |
| 8. Speedometer spindle | 51. Ball bearing     |
| 9. Nut                 | 52. Circlip          |
| 10. Cover              | 53. Output shaft     |
| 11. Gasket             | 54. Flange           |
| 12. Roller bearing     | 55. O-ring           |
| 13. Intermediate gear  | 56. Shaft            |
| 14. Spacer sleeve      | 57. O-ring           |
| 15. Shims              | 58. Plug             |
| 16. Roller bearing     | 59. Split pin bolt   |
| 17. Circlip            | 60. Housing          |
| 18. Ball bearing       | 61. Washer           |
| 19. Cluster gear       | 62. Split pin        |
| 20. Ball bearing       | 63. Shift fork       |
| 21. Spring             | 64. Shaft            |
| 22. Ball               | 65. Roller bearing   |
| 23. Switch             | 66. Washer           |
| 24. Cover              | 67. Housing          |
| 25. Bolt               | 68. Washer           |
| 26. Shift rail         | 69. Roller bearing   |
| 27. Shift fork         | 70. Outer ring       |
| 28. Seal               | 71. Shims            |
| 29. Thrust rod         | 72. Speedometer gear |
| 30. Cover              | 73. Housing          |
| 31. Holed nut          | 74. Shaft            |
| 32. Nut                | 75. Needle bearing   |
| 33. Washer             | 76. Gear, low-speed  |
| 34. Spacer washer      | 77. Cone             |
| 35. Diaphragm          | 78. Spring           |
| 36. Washer             | 79. Inhibitor        |
| 37. Nut                | 80. Hub              |
| 38. Thrust spring      | 81. Spring           |
| 39. Screw              | 82. Cone             |
| 40. Vacuum cylinder    | 83. Engaging sleeve  |
| 41. Nut                | 84. Gear, high-speed |
| 42. Bolt               | 85. Needle bearing   |
| 43. Clamp              | 86. Inner race       |



## GROUP 45 PROPELLER SHAFTS

### Description

The vehicle is provided with two propeller shafts which are placed between the auxiliary gearbox and the differential carrier, see Figs. 45-1 and 45-2. Both propeller shafts are provided with slip joints in order to take up the changes that arise between the

gearbox and differential carrier. To ensure complete lubrication of the spiders in the universal joints and the slip joints, the shafts are provided with lubricating nipples and in order to protect the slip joint, it is protected with a rubber bellows cover.

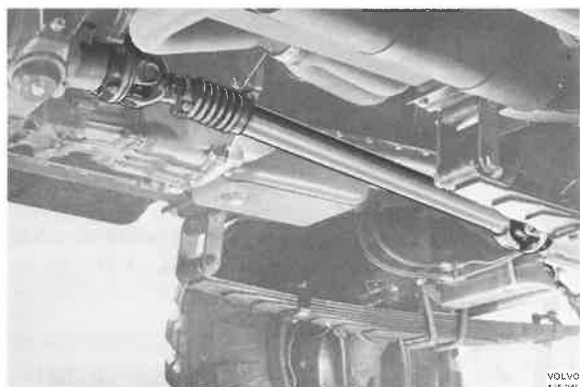


Fig. 45-1. Front propeller shaft

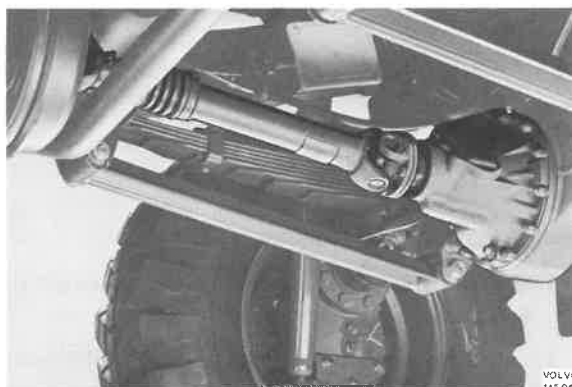


Fig. 45-2. Rear propeller shaft



Fig. 45-3. Propeller shaft

### Service procedures

#### Replacing a propeller shaft

When replacing a propeller shaft, any lock washers should be replaced and the slip joint rubber bellows cover checked for damage. When fitting the flanges, always make sure that the contact surfaces are clean and free from dirt. The bolts should always be tightened to a torque of 55-65 Nm (5.5-6.5 kpm =

40-47 lbftf) and the spiders as well as the slide joint should be lubricated. The spider should be greased so much that grease squeezes out at all four needle bearings. Grease the slide joint until squeezes out at the overflow valve (in the centre of the fork or when the slide joint shows a tendency to extend itself).

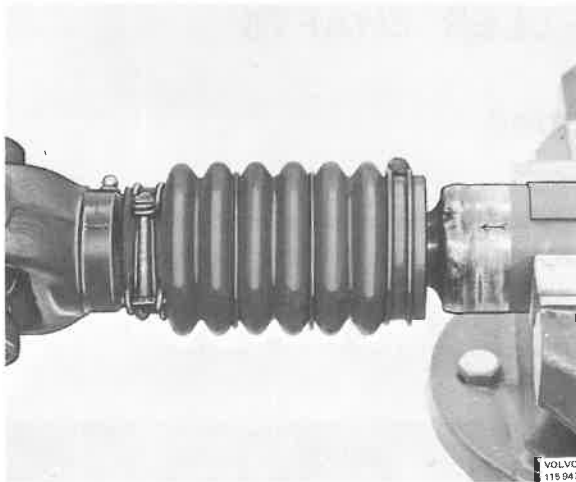


Fig. 45-4. Removing the axle

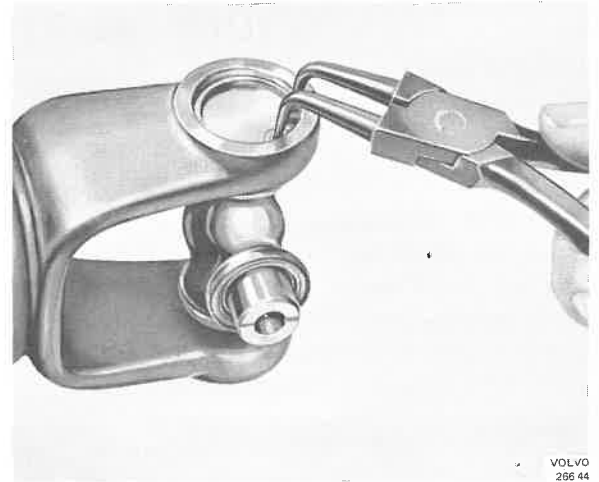


Fig. 45-6. Removing the circlip

### Replacing the rubber bellows

1. Jack up the vehicle so that the wheels are off the ground.
2. Remove the propeller shaft from the differential carrier flange.
3. Remove the hose clamps on the rubber bellows. Pull out the propeller shaft tube from the slide joint.
4. Remove the bellows and clean the surfaces for the bellows on the tube and slide joint.
5. Fit the hose clamps on the new bellows and place the bellows on the propeller shaft tube.
6. Check to make sure that the slide joint is free from dirt. Push the tube into the slide joint and note the line-up marks when doing so, see Fig. 45-4.

7. Fit the propeller shaft to the differential carrier. Tighten up the bolts to a torque of 55–65 Nm (5.5–6.5 kpm = 40–47 lbftf).
8. Place the rubber bellows in position on the propeller shaft tube. Fit and tighten up the hose clamp.
9. Before tightening up the other end of the bellows, the propeller shaft must be pulled out to its full length.  
On two-axle vehicles, the propeller shaft is pulled out to its full length when the wheel carrier gear hangs freely.  
On three-axle vehicles, the propeller shaft is pulled out to its full length to the bogie when one of the carrier gears hangs freely and the other is raised to a maximum.

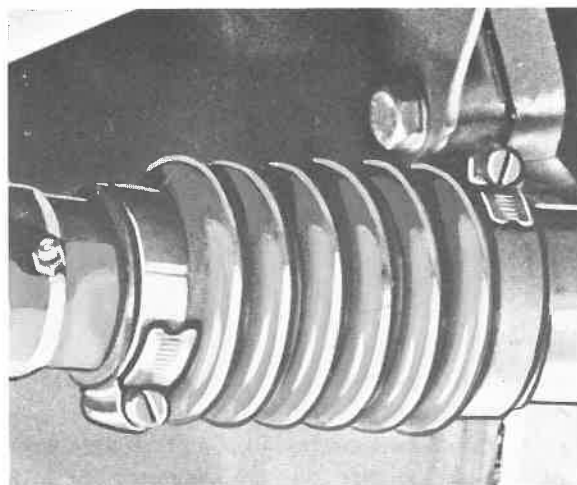


Fig. 45-5. Adjusting the clamp



Fig. 45-7. Driving out the bearing

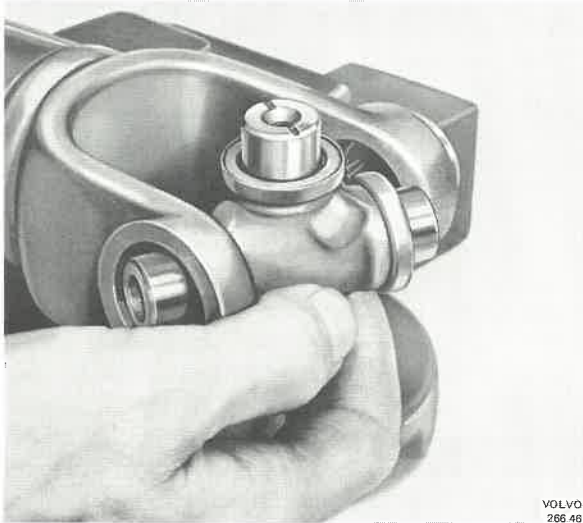


Fig. 45-8. Removing the spider

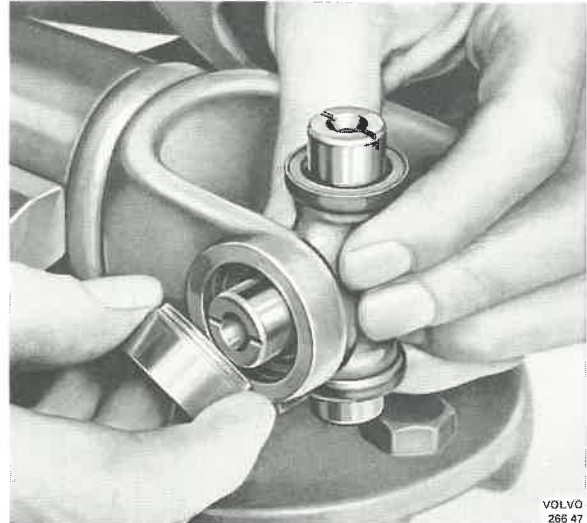


Fig. 45-9. Fitting the bearing

10. Lower the vehicle.
11. Lubricate the slide joint. This must be done when the vehicle is lowered otherwise too much grease can be added.

### Replacing universal joint

#### Disassembling

1. Secure the propeller shaft tube in a vice so that the universal joint is as near the vice as possible. Note that the tube must not be damaged since if it is deformed it can cause imbalance.
2. Remove the circlips securing the needle bearings, see Fig. 45-6.
3. With the help of a drift drive the spider as far as possible in one direction, see Fig. 45-7.
4. Then drive the spider in the opposite direction as far as possible.

#### Assembling

1. Remove the needle bearings from the spider.
2. Place the spider in the flange, see Fig. 45-9, and fit the needle bearing. Make sure that the rollers in the bearing are located correctly. Press in the bearing and fit the circlip.
3. Push the spider in the one direction so far that the needle bearing can be fitted. Press in the bearing and fit the circlip.
4. Fix securely the spider in the propeller shaft tube in the same way.
5. Lubricate the spider.

## GROUP 46 REAR AXLE AND FRONT AXLE

### Description

#### DIFFERENTIAL CARRIERS

The differential carriers, see Figs. 46-1 and 46-2 as well as Illustrations 46-A and -B, are of the so-called "spiral-bevel" type which means that the centreline of the pinion coincides with that of the crown wheel, see Fig. 46-3. Front and gear differential carriers are similar. Since they are turned in their own direction, the drive side of the crown wheel is not regarded as the same side as the gears in both carriers. In order to prevent the differential pinion from rotating when driving on a slippery surface, the differentials are provided with a lock, see Figs. 46-4 and 46-5. The lock is operated from a control panel, see Fig. 46-6. The control cylinder on the rear axle casing or front axle casing is actuated by vacuum. In order to indicate when the control cylinder is under vacuum, indicators are placed on the line to the front and rear axle casings respectively (Fig. 46-7). They switch on the differential lock lights on the instrument panel.

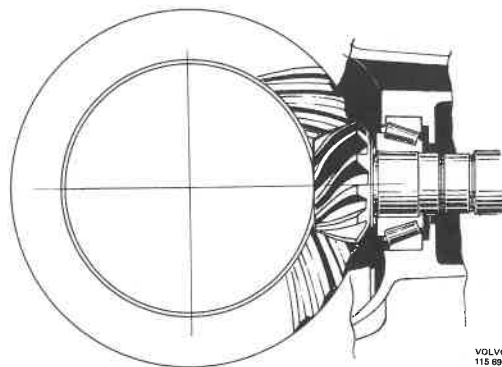


Fig. 46-3. Spiral bevel

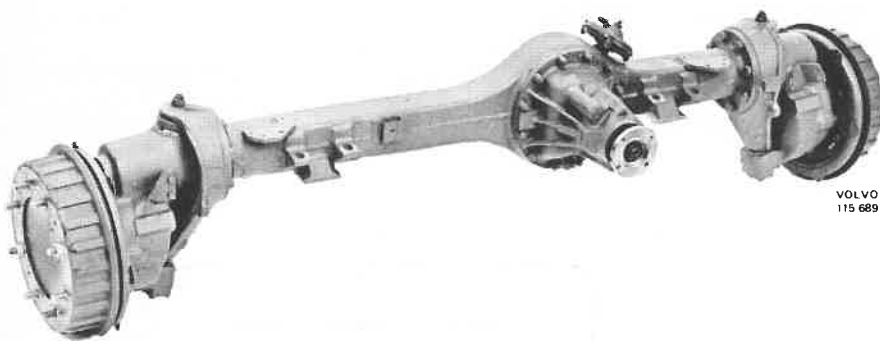


Fig. 46-1. Front axle

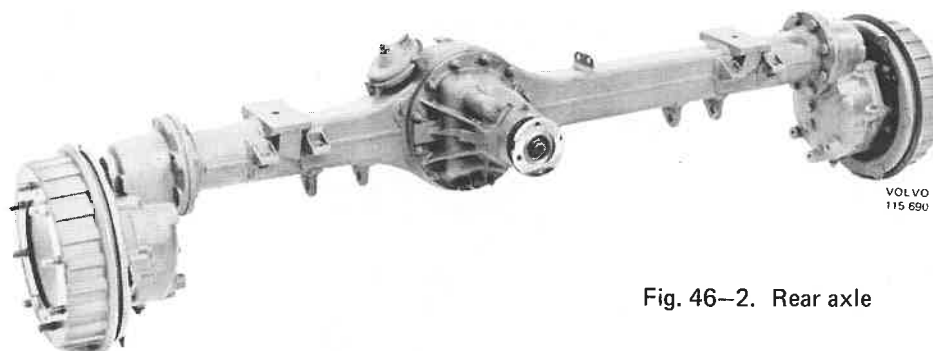


Fig. 46-2. Rear axle

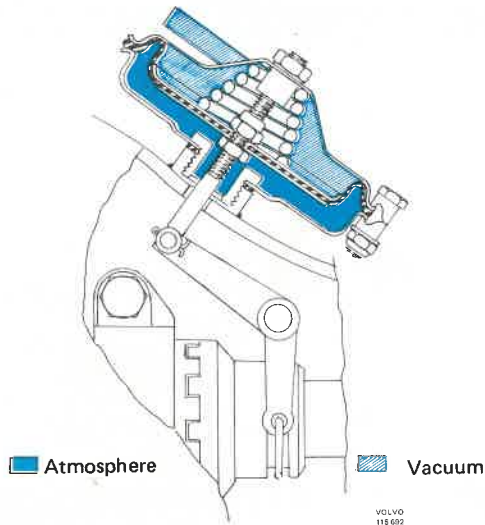


Fig. 46-4. Differential lock

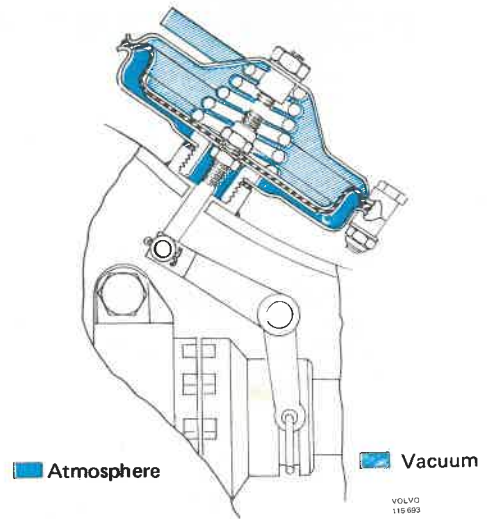


Fig. 46-5. Differential lock

**WHEEL CARRIERS**

In order that the vehicle should have a high ground clearance without the necessity of having excessively large wheels, the front and rear axles have been provided with wheel carriers, see Figs. 46-8 and 46-9. The wheel carries consist of a large and a small gear, see the Illustration 46-C, E and F. the gears have straight teeth. The small gear is journalled in the wheel carrier housing in a ball bearing and a needle bearing. The large gear is fixed to the wheel hub

shaft, which is journalled in a housing bolted to the wheel carrier housing. The housing is partly filled with oil for lubricating the wheel carriers.

To prevent oil from the wheel carrier running over into the differential carrier casing, a seal is fixed on the rear wheel carrier housing. This seal consists of a sealing ring with wear ring, Illustration 46-D, and an X-ring which sits on the drive shaft. The seal for the front wheel carrier consists of rubber bellows, see Illustration 46-C.

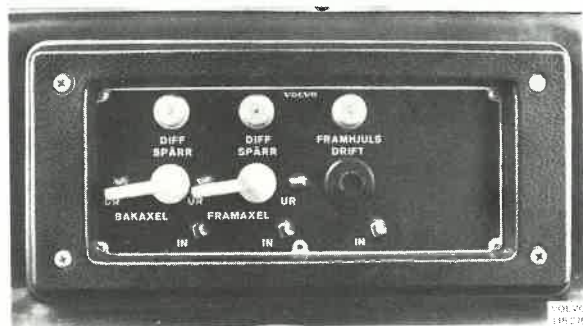


Fig. 46-6. Operating controls

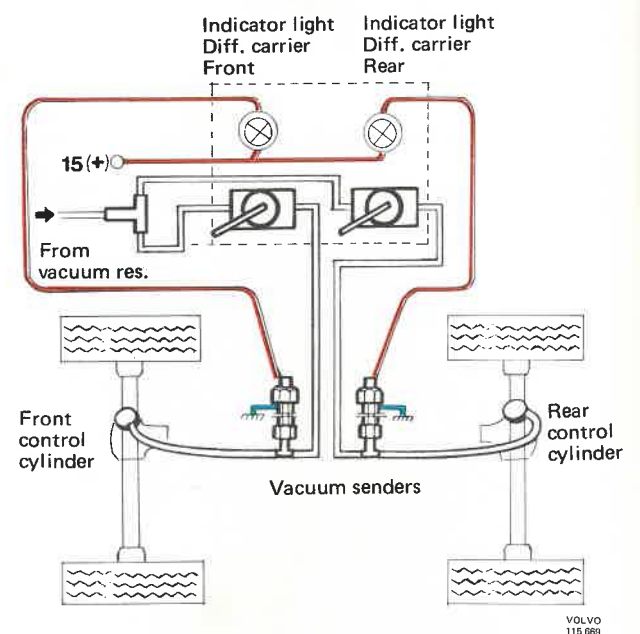


Fig. 46-7. Diff. carrier senders and indic. lights

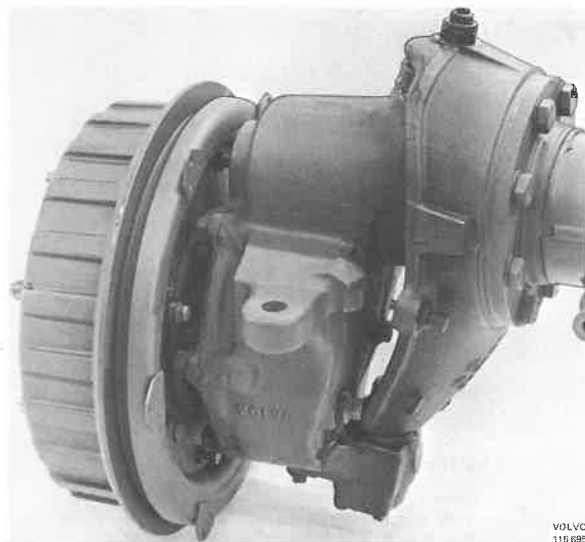


Fig. 46-8. Front wheel carrier

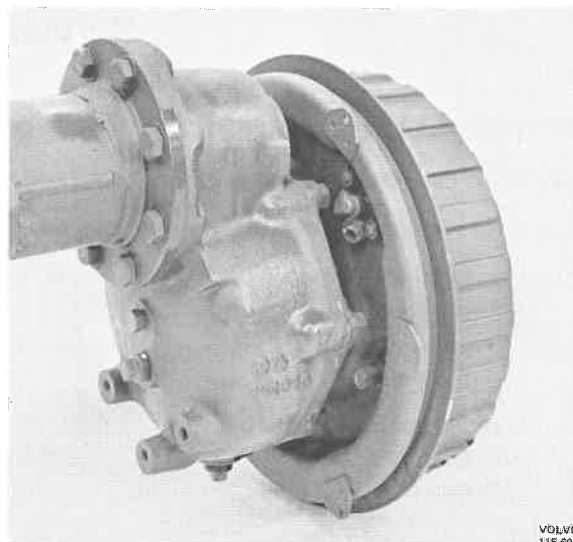


Fig. 46-9. Rear wheel carrier

### Power take-off for tandem drive

On 3-axle vehicles with tandem drive, the leading differential carrier, Fig. 46-10, is fitted with a power take-off for driving the trailing differential carrier. A propeller shaft is fitted between the power take-off and the trailing differential carrier. The power take-off is fixed to the differential carrier housing. It differs, therefore, from the vehicle's two other differential carriers by the fact that it has a cover in the housing and a gear wheel which sits on the pinion.

The construction of the power take-off can be seen from Fig. 46-11 and Illustrations 46-G and H. It consists of two parts, a housing in which two gears are journaled and a housing in which the output shaft is journaled. One of the gears, called the intermediate gear, cannot be displaced on its shaft but is in constant mesh with the gear on the pinion and the gear on the power take-off. The power take-off output shaft will, therefore, always rotate at the same speed as the speed of the pinion.

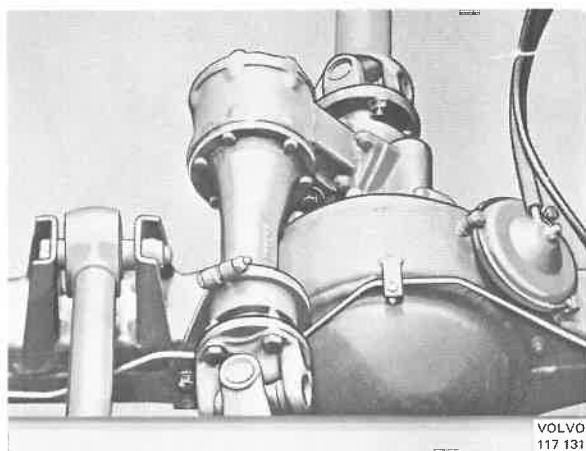


Fig. 46-10. Power take-off on the differential carrier

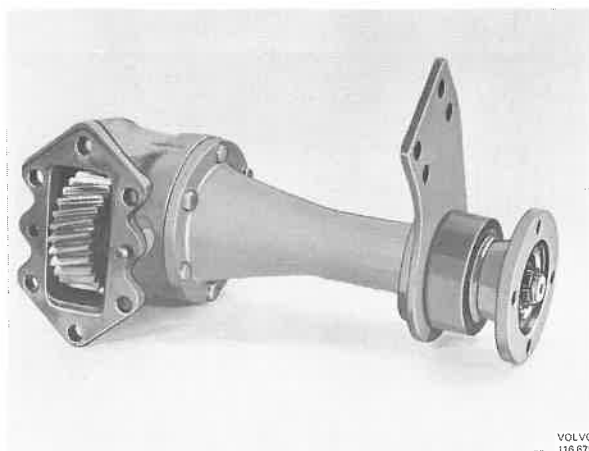


Fig. 46-11. Power take-off

## Service procedures

### DIFFERENTIAL CARRIERS

#### Work on carriers in vehicle

##### *Replacing O-rings on differential lock control handle*

1. Place a suitable tool under the handle, and pull the handle out of the housing.
2. Replace the O-ring on the handle, Fig. 46-12, and coat it with a little grease.
3. Press the handle into the housing. Check to make sure that the differential lock can be engaged and disengaged.

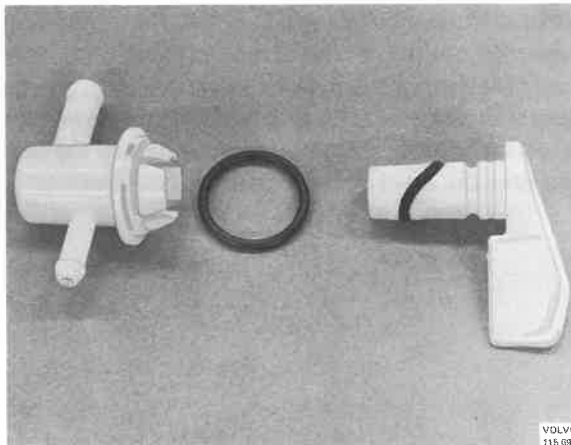


Fig. 46-12. Differential lock control

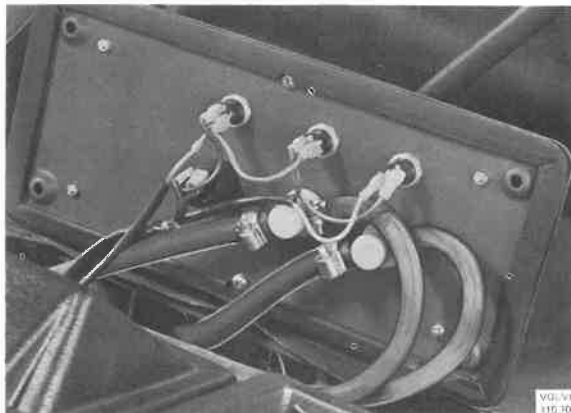


Fig. 46-13. Differential lock controls

##### *Replacing differential carrier control*

1. Place a suitable tool under the knob and pull the knob out of the housing.
2. Remove the four screws securing the plate.
3. Remove the lock ring which holds the control housing to the controls panel.  
Screw loose the panel. Disconnect the hoses from the housing, see Fig. 46-13.
4. Remove the knob from the new control.
5. Place a new O-ring on the housing and fit the housing on the panel. Fit the lock ring.
6. Connect up the hoses. Fit the panel. Screw tight the plate.
7. Press the knob into the housing. Check the function of the differential carriers.

##### *Replacing the flange seal*

1. Remove the bolts holding the propeller shaft and remove the shaft.
2. Fix counterhold 2837 on the flange, Fig. 46-14. Unscrew the nut.
3. Fit puller 2261, Fig. 46-15, and pull off the flange.
4. Pull out the seal with 4030, Fig. 46-16.

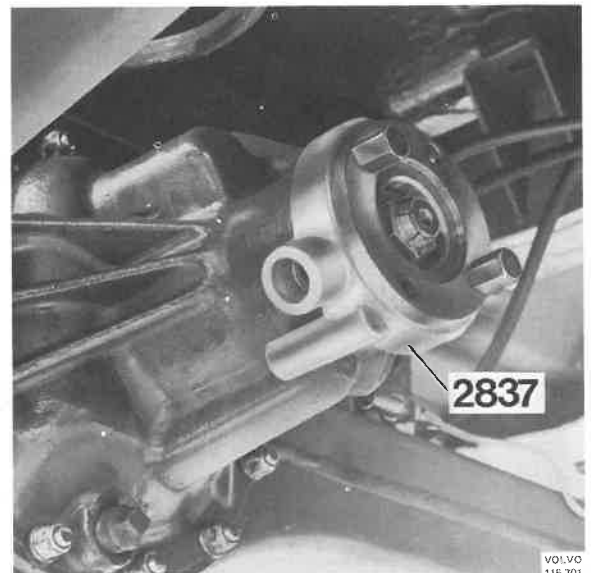


Fig. 46-14. Fitting a counterhold

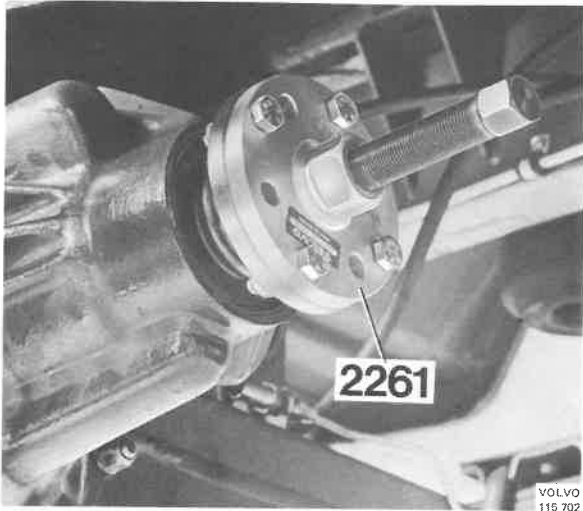
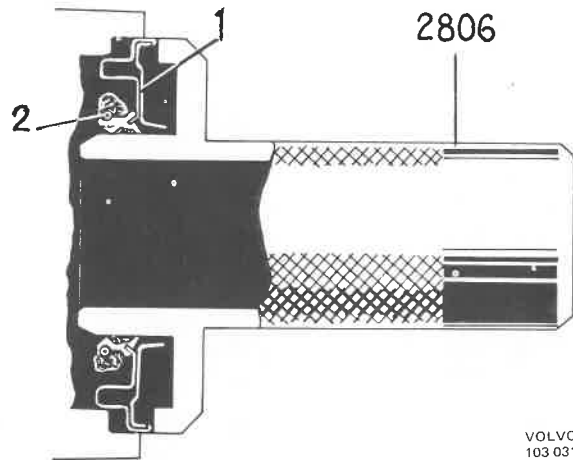


Fig. 46-15. Removing the flange



- 1. Sealing ring
- 2. Spring with grease layer

Fig. 46-17. Installing the sealing ring

5. Grease the contact surface of the new seal which faces the flange and on the reverse side of the sealing lip, Fig. 46-17.
6. Drive the seal into the housing with 2806.
7. Pull on the flange with 1845, Fig. 46-18. Remove the tool and fit 2837. Fit the nut and tighten it to a torque of 280-300 Nm (28-30 kpm = 202-217 lbftf).
8. Fit and tighten up the propeller shaft. Tighten the bolts to a torque of 55-65 Nm (5.5-6.5 kpm = 40-47 lbftf).

*Replacing the control cylinder diaphragm*

1. Remove the bolts, Fig. 46-19, holding the cylinder cover. Remove the cover.
2. Remove the spring. Remove the nut on the pull rod. Hold securely the thrust washer and diaphragm.

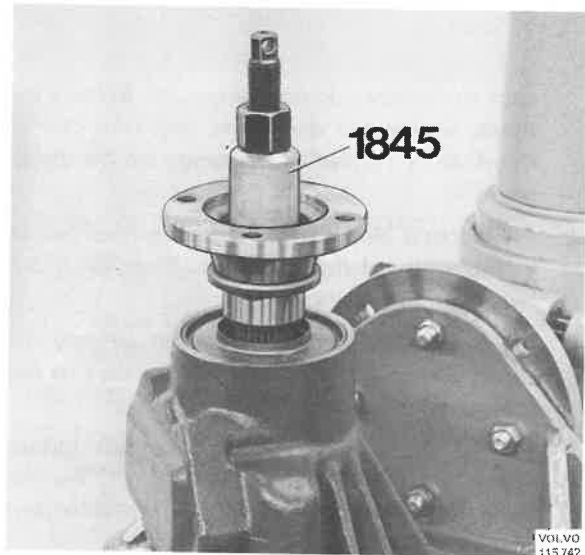


Fig. 46-18. Pressing on the flange

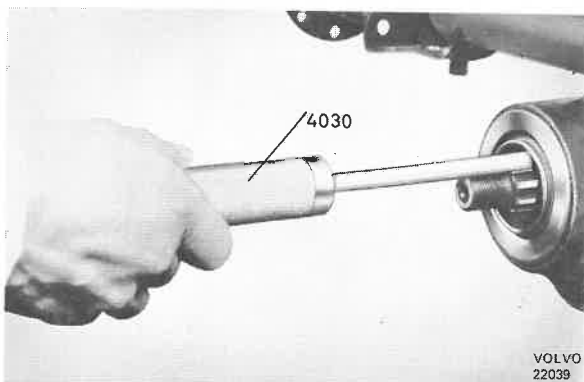
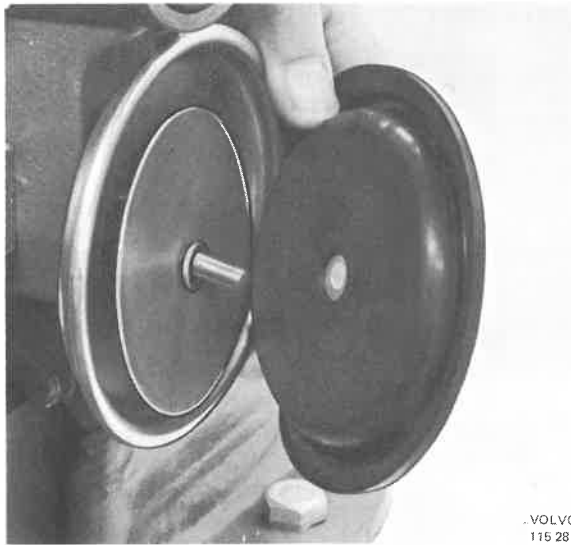


Fig. 46-16. Removing the seal



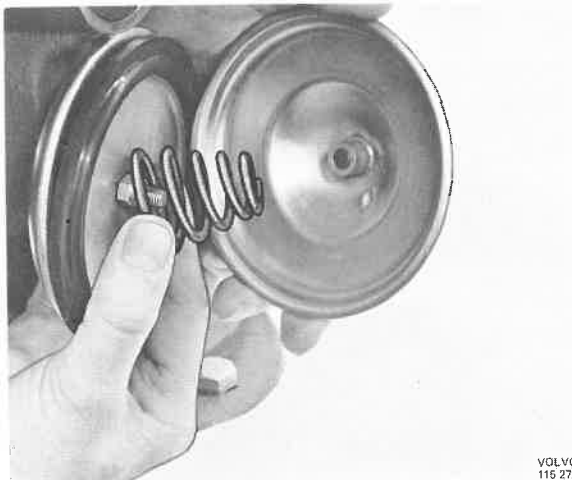
Fig. 46-19. Control cylinder



VOLVO  
115 281

Fig. 46-20. Fitting diaphragm

- ragm so that they do not spin round. Remove the thrust washer and diaphragm, and take care of the distance washer in the centre of the diaphragm.
3. Fit the new diaphragm. Fit the distance washer in the centre of the diaphragm. Place the thrust washer on the diaphragm.
  4. Fit and tighten up the nut. Hold securely the thrust washer and diaphragm so that they do not spin round when the nut is tightened up.
  5. Fit the spring with the large contact surface facing the thrust washer, Fig. 46-21. Fit the cover. Fit the bolts evenly round the cover and tighten up.



VOLVO  
115 272

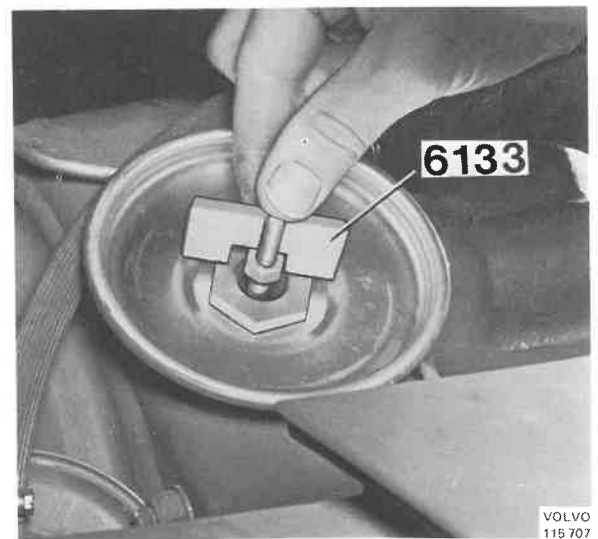
Fig. 46-21. Installing the spring



Fig. 46-22. Control cylinder

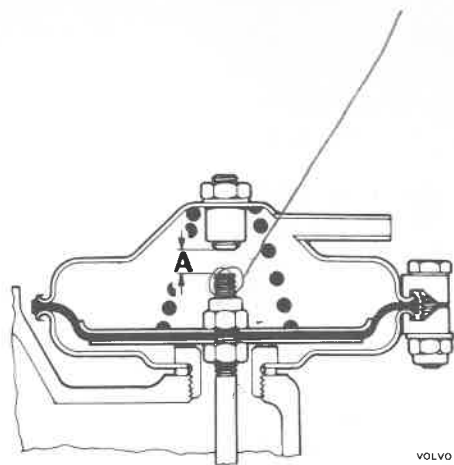
#### *Adjusting the differential lock*

1. Unscrew the wheel nuts on the wheel which is on the same side as the control cylinder (right-hand side).
2. Jack up the vehicle and remove the wheel.
3. Remove the bolts securing the control cylinder cover, Fig. 46-22. Remove the cover.
4. Remove the spring. Remove the nut on the pull rod. Remove the diaphragm and the thrust washers. Take care of the washer in the centre of the diaphragm.
5. Lift up the pull rod and adjust the nut, Fig. 46-23, so that it is flush with the gauge 6133. If there is no gauge, the distance should be 9 mm (0.36") between the holed nut and the nut, when the differential lock is engaged.



VOLVO  
115 707

Fig. 46-23. Adjusting the pull rod

VOLVO  
115 282

A = 6 3/8 turns (9,2 mm)

Fig. 46-24. Adjusting the bolt

6. Fit the thrust washer and diaphragm. Fit the copper washer in the centre of the diaphragm. Fit the other thrust washer.
7. Fit on the upper nut. Hold securely the lower nut, the thrust washers and the diaphragm so that they do not rotate when the nut is tightened up.
8. Fit the spring with the large contact surface facing the thrust washer, Fig. 46-24. Fit the cover. Fit the bolts evenly round the cover and tighten up.
9. Remove the lock nut for the bolt on the cover. Screw down the bolt so that it bottoms against the thrust rod. Then screw it back 6 3/8, approx 9,2 mm (0.36") turns and lock it with the lock nut, Fig. 46-24.
10. Check with the control for the differential lock that the lock engages and disengages properly.

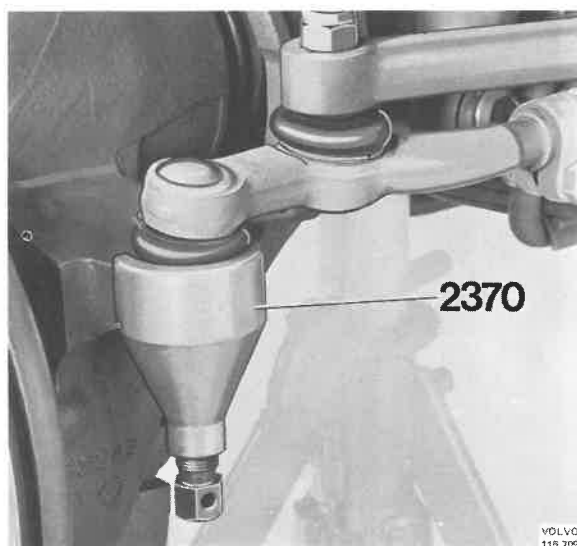
VOLVO  
115 709

Fig. 46-25. Removing the ball joint

VOLVO  
115 710

Fig. 46-26. Removing the wheel carrier

## Replacing the differential carriers

### Removing the front differential carrier

1. Release the wheel nuts on both wheels. Jack up the vehicle.
2. Remove the wheels.
3. Drain the oil from the differential carrier. Remove the nut on the ball joints for the steering rods. Disconnect the ball joint from the steering arm with 2370, Fig. 46-25.
4. Remove the plate for the hollow rubber spring. Remove the upper bolts and fit the guide pins 6131, see Fig. 46-26.
5. Remove the lower bolts securing the wheel carrier housing to the front axle casing. Place a jack under the wheel carrier housing.
6. Pull out the wheel carrier housing with drive shaft at least 100 mm (4") or the maximum length permitted by the brake hoses. Remove the jack and support under the wheel carrier housing.
7. Disconnect the other wheel carrier housing in the same way.
8. Remove the propeller shaft from the differential carrier flange, Fig. 46-27.
9. Remove the nuts securing the differential carrier and remove the carrier.
10. For replacement of the differential sleeve, see under "Replacing the differential sleeve".

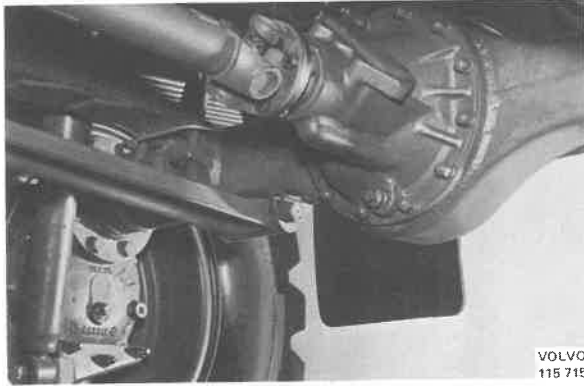


Fig. 46-27. Differential sleeve

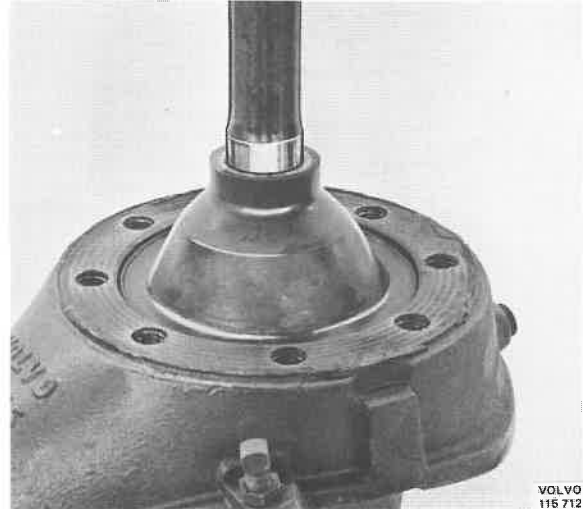


Fig. 46-29. Location of rubber dust cover

### Installing the front differential carrier

1. Check the selector fork for the differential gear for wear. Concerning eventual replacement of the differential lock or fork, see under "Replacing the differential sleeve".
2. Clean the contact face of the casing and coat it with sealing agent. Make sure that the flange sleeve of the differential lock on the differential carrier is on the right side. Place the differential carrier in position. Fit the washers and nuts in position and tighten up the carrier.

3. Fit the propeller shaft. Tighten the bolts to a torque of 55-65 Nm (5.5-6.5 kpm = 40-47 lbftf).
4. **NOTE!** Check that the rubber dust cover for the drive shaft is fitted properly on the steering knuckle support, see Fig. 46-29, before fitting the wheel carrier and support together.

Lift up the drive shaft while pushing in the differential carrier, Fig. 46-30. When the drive shaft touches the differential, rotate the differential carrier flange while pushing the carrier to the bottom at the same time.

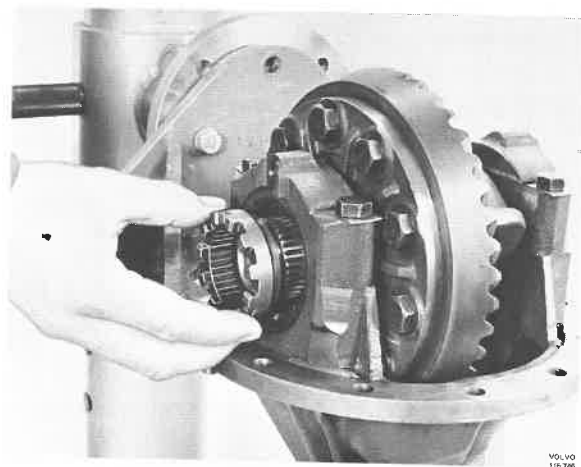


Fig. 46-28. Flange sleeve



Fig. 46-30. Fitting the carrier

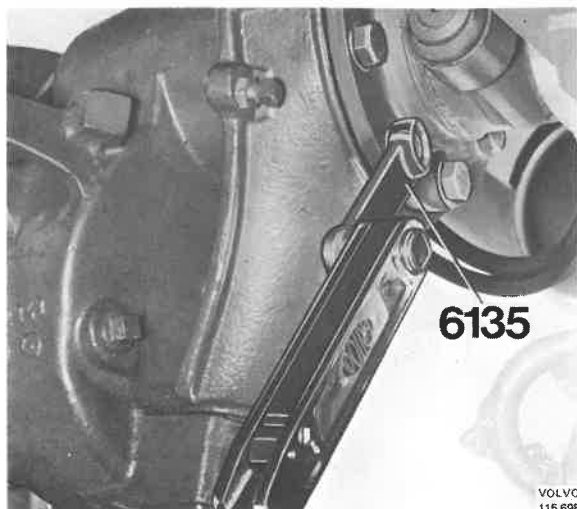


Fig. 46-31. Tighten the nuts

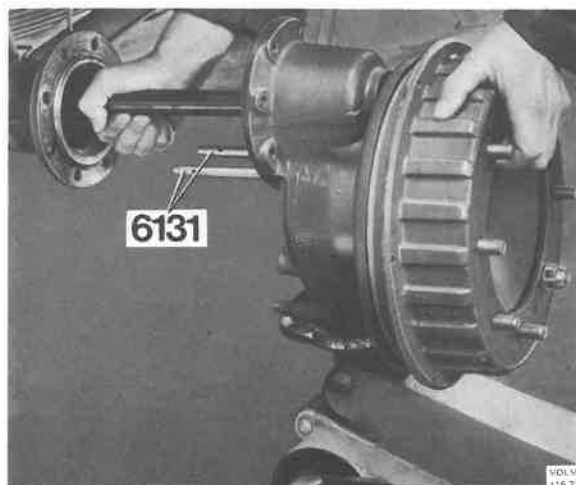


Fig. 46-33. Removing the wheel carrier

5. Fit the bolts round the front axle casing. Remove the guide pins. Tighten the bolts to a torque of 100–120 Nm (10–12 kpm = 72–87 lbftf). Use 6135, see Fig. 46-31. Remove the jack.
6. Fix the plate on for the hollow rubber spring.
7. Fit the lower steering rod. Check that the lubricating nipple is not damaged.
8. Fit the other wheel carrier housing in the same way (points 4–6).
9. Fill the carrier with oil. Concerning quantity and type, see under "Data".
10. Adjust the differential lock, see the separate instructions.

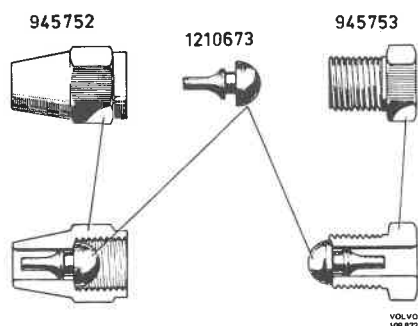


Fig. 46-32. Sealing nipples

11. Fit the wheels. Lower the vehicle and tighten the wheel nuts to a torque of 210 Nm (21 kpm = 152 lbftf).

#### Removing the rear differential carrier

1. Release the wheel nuts on both rear wheels. Jack up the rear of the vehicle.
2. Remove the wheels.
3. Drain the oil from the differential carrier.
4. Remove the shock absorber from its lower attachment. Disconnect the brake line from the wheel cylinder. Plug the line with a sealing nipple, see Fig. 46-32. Volvo nos. 245752 + 1210673.
5. Place a jack under the wheel carrier housing, see Fig. 46-33. Remove the bolts securing the wheel carrier housing to the rear axle casing. Allow two bolts to remain. Tap carefully on the bolts so that the housing loosens from the casing.
6. Remove the bolts and pull out the wheel carrier housing with the drive shaft.
7. Remove the other wheel carrier housing in the same way.
8. Remove the propeller shaft from the differential carrier flange, Fig. 46-27.
9. Remove the nuts securing the differential carrier and remove the carrier.
10. For replacement of the differential sleeve, see under "Replacing the differential sleeve".

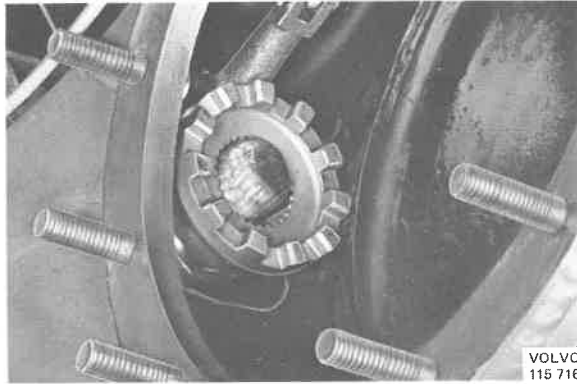


Fig. 46-34. Differential carrier



Fig. 46-36. Tighten the nuts

### Installing the rear differential carrier

1. Check the selector fork for the differential lock for wear. In the event the lock or the fork has to be replaced, see the special instructions. Lift up the flange and hold it in position with a suitable tool, see Fig. 46-35.
2. Clean the contact face of the casing and coat it with sealing agent. Check that the differential lock flange sleeve on the differential carrier is on the right side. Place the differential carrier in position. Fit washers and nuts in position and tighten up the carrier.
3. Fit the propeller shaft. Tighten the bolts to a torque of 55-65 Nm (5.5-6.5 kpm = 40-47 lbftf).

4. Remove the tool holding the flange. Fit two guide pins 6131 in the lower holes of the wheel carrier housing, Fig. 46-33. Place the housing on a jack. Lift up the carrier so that the guide pins can enter the rear axle casing. Rotate the differential carrier flange while pushing in the carrier at the same time.
5. Fit the bolts round the casing. Remove the guide pins. Tighten the bolts to a torque of 100-120 Nm (10-12 kpm = 72-87 lbftf). Use 6135, see Fig. 46-36. Remove the jack.
6. Fit the shock absorber. Fit and tighten up the brake pipe.

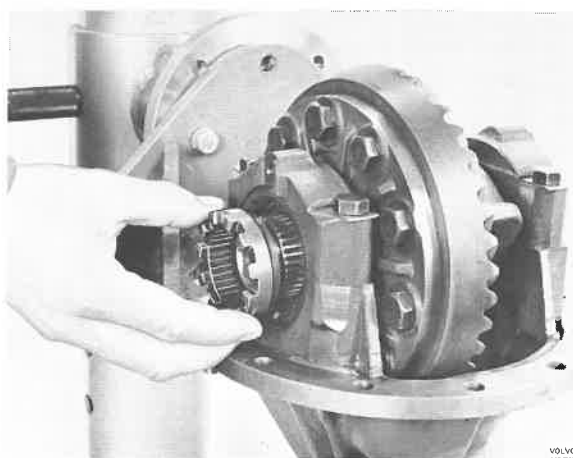


Fig. 46-35. Differential lock flange

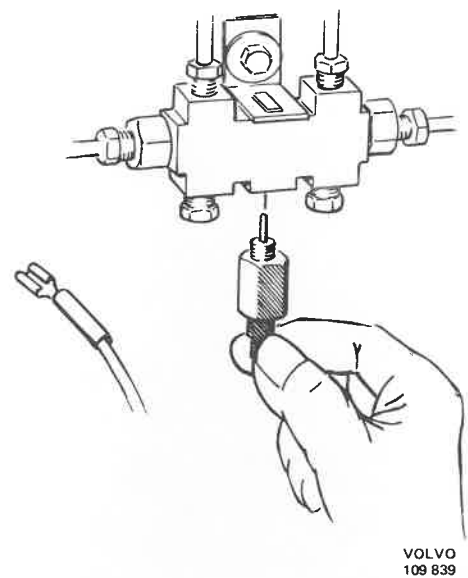
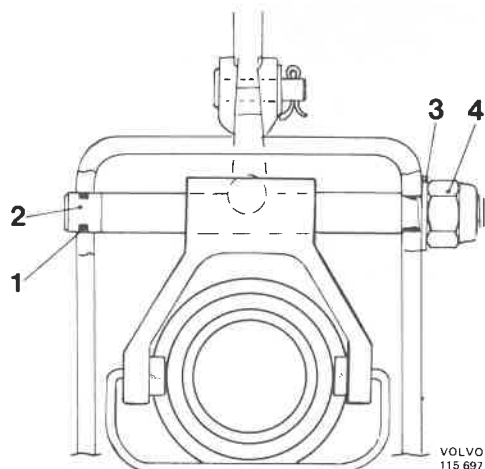


Fig. 46-37. Removing the contact



- |           |           |
|-----------|-----------|
| 1. O-ring | 3. Washer |
| 2. Shaft  | 4. Nut    |

Fig. 46-38. Differential sleeve

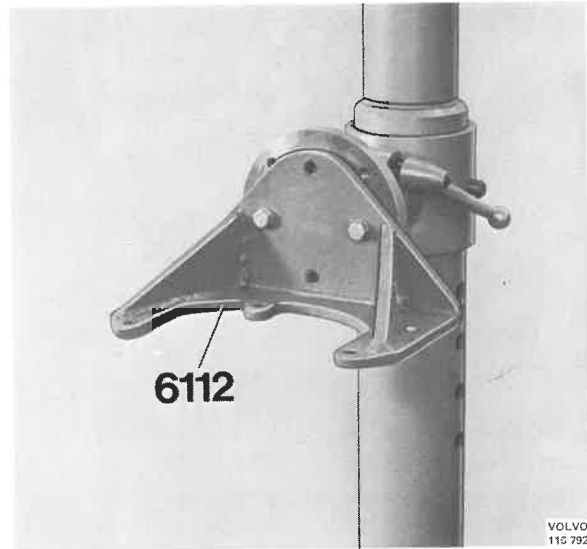


Fig. 46-39. Fixture for the differential carrier

7. Fit the other wheel carrier housing in the same way. Bleed the wheel cylinders on the rear wheels. The electrical contact for the pressure difference should be removed, see Fig. 46-37, during the bleeding. If a bleeder unit is used, the working pressure should be 0.2 MPa (2 kp/cm<sup>2</sup> = 28 lbf/in<sup>2</sup>). For more detailed instructions with regard to bleeding, see Part 5. Fill the differential carrier with oil. Concerning quantity and type, see under "Data".
8. Fit the wheels.
9. Lower the vehicle. Tighten the wheel nuts to a torque of 210 Nm (21 kpm = 152 lbftf).

#### Replacing the differential sleeve (with differential carrier removed)

1. Remove the nut from the shaft (Fig. 46-38). Drive out the shaft with a plastic mallet.
2. Remove the sleeve from the drive shaft. Remove the sleeve from the fork.
3. Check that the fork, or the shaft, is not damaged. If necessary, replace the requisite parts.
4. Fit the new sleeve on the fork. Push the sleeve onto the drive shaft.
5. Fit a new O-ring on the shaft. Place the shaft in position. Fit and tighten up the nut.

#### Disassembling the differential carrier

Special tools: 1801, 2261, 2392, 2567, 2837, 4030, 6014, 6115.

1. Clean the outside of the carrier. Place the carrier in fixture 6112, Fig. 46-39.

2. Check to make sure the bearing caps are marked.
3. Bend up the tabs on the lock washer for the cap bolts. Remove the bolts and the lock rings for the adjuster nuts.
4. Remove the cap bolts. Remove the caps.
5. Remove the differential housing with adjuster nuts and bearing.
6. Remove the oil scraper and spring, Fig. 46-40.

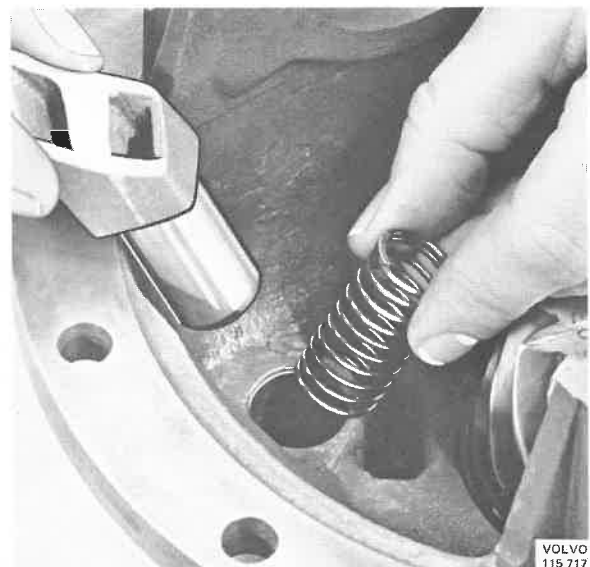


Fig. 46-40. Removing the oil scraper

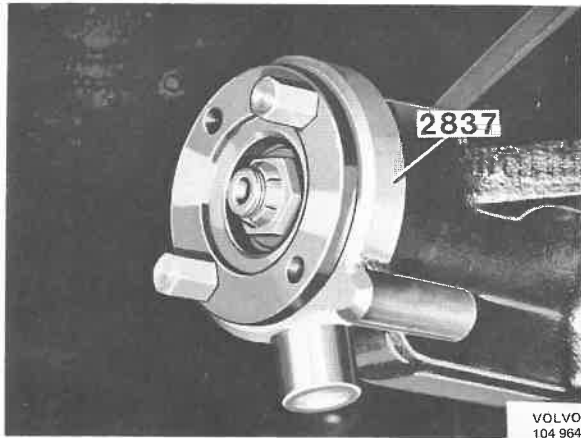


Fig. 46-41. Fitting a puller



Fig. 46-44. Driving out the seal

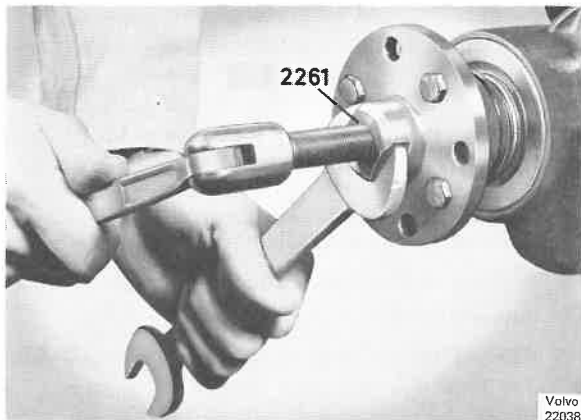


Fig. 46-42. Removing the flange

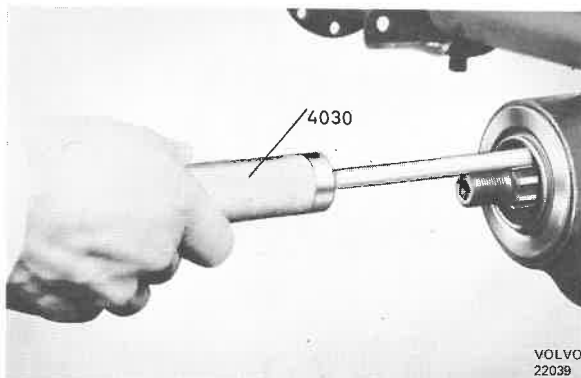


Fig. 46-43. Removing the seal

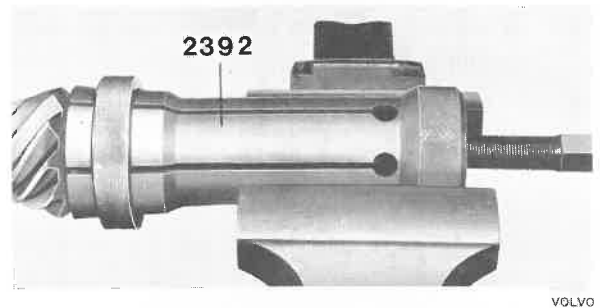
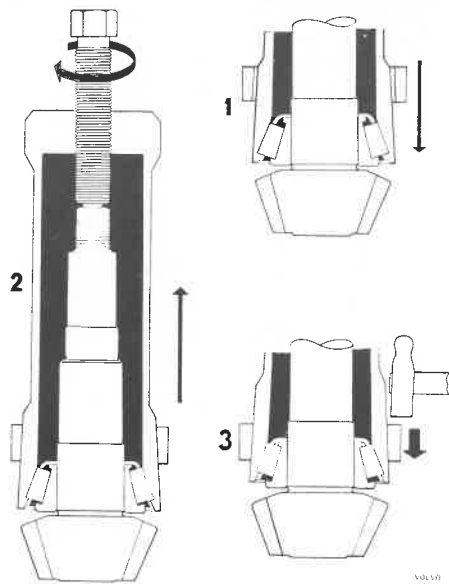


Fig. 46-45. Removing the bearing

7. Turn the carrier. Fit counterhold 2837 on the flange, Fig. 46-41. Remove the flange nut.
8. Remove the counterhold. Fit 2261 on the flange, Fig. 46-42. Remove the flange. Pull out the flange seal with 4030, see Fig. 46-43. Remove the oil deflector plate.
9. Drive out the pinion with a plastic mallet. Take care of the shims and spacer sleeve.
10. Turn the carrier. With 6014 + 1801 drive out the flange seal, front bearing and outer race, Fig. 46-44.
11. Turn the carrier. Drive out the outer race for the rear bearing with 6115 + 1801.
12. Remove the bearing from the pinion with 2392, Fig. 46-45. Note how the tool is attached, Fig. 46-46.



1. Puller is pushed over the rollers
2. Rollers pulled up
3. Circlip knocked tight

Fig. 46-46. Fitting the puller



Fig. 46-48. Removing the washer

*Disassembling a differential housing*

1. Fix the housing in a vice. Remove the bolts securing the crown wheel. Remove the crown wheel.

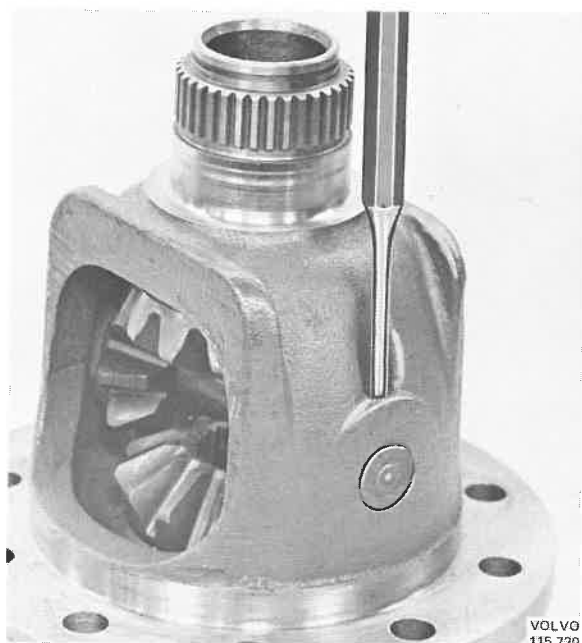


Fig. 46-47. Driving out the lock pin

2. Drive out the lock pin, Fig. 46-47, which holds the shaft for the differential gears.
3. Drive out the shaft. Rotate the differential side gears. Remove the pinions and thrust washers, Fig. 46-48. Remove the differential side gears and washers.
4. Remove the differential bearings with 2567, Fig. 46-49.

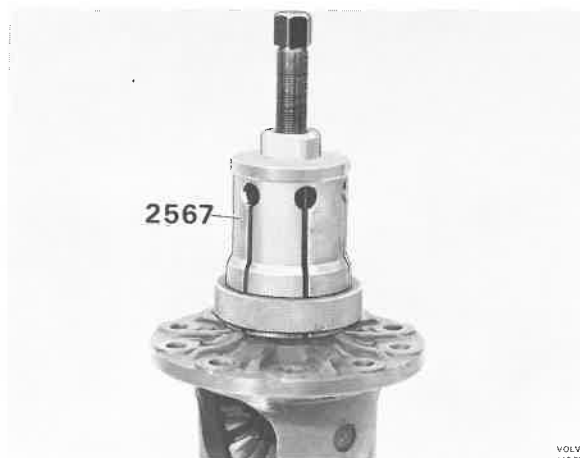


Fig. 46-49. Removing the bearing

### Checking and replacing parts

First clean all parts thoroughly. Examine all bearing races and bearings. There must not be any scoring or other damage on the bearings, rollers or roller cages. All damaged bearings and bearing races are to be replaced and the bolts for the crown wheel should always be replaced.

Examine both the pinion and crown wheel thoroughly for damage to the gear teeth. This can be caused by incorrect running-in, wrong oil, insufficient backlash or incorrect tooth mesh. Unless the reason for the seizing is removed at an early stage, this will lead eventually to entirely ruined gears.

Also check the differential gears for damage to the teeth. If any gear is damaged replace all four differentials, since they are nowadays matched for better meshing.

Check also the cylindrical section of the flange which enters the sealing ring to see where it is worn or scored. If it is, replace the flange together with the sealing ring.

The pinion ring has a slot for locking. In time this loses its locking ability. For this reason, the nut should be replaced if it has been taken off a couple of times. The washer under the nut should also be changed if it has become warped.

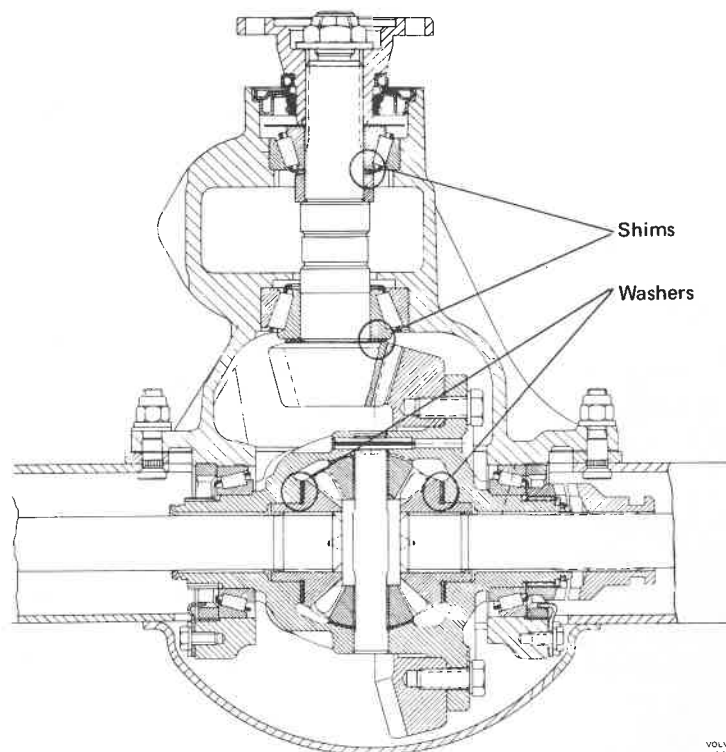
### Assembling

When assembling and adjusting the final drives and carrier differentials, the greatest cleanliness must be observed. Dirt in a tapered roller bearing can lead to entirely incorrect measurements.

When measuring the bearing clearance or the pre-loading, the bearings should be oiled and should have been rotated several times under load.

It is not necessary to check the mesh pattern on the gear teeth if the pinion and backlash have been adjusted according to the instructions given for assembling the final drive.

Washers and shims of different thicknesses are fitted in some places (see Fig. 46–50) in order to obtain correct clearance.



VOLVO  
115 954

Fig. 46–50. Shims or washers



Fig. 46-51. Fitting the thrust washers

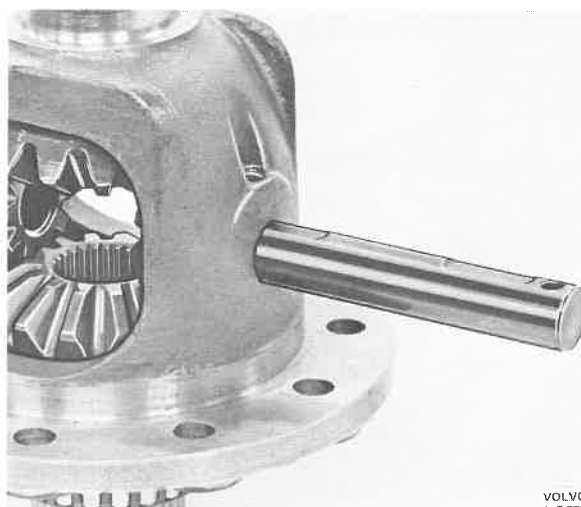


Fig. 46-53. Driving in the shaft

#### Assembling the differential housing

- Grease the teeth and slide surfaces on the differential gears. Oil the thrust washers.
- Place the differential side gears and thrust washers in the housing, see Fig. 46-51.
- Place the dished thrust washers on the differential pinions. Place the pinions opposite each other on the differential side gears, Fig. 46-52. Roll in the pinions at the same time. Check to make sure the washers are fitted properly.
- Drive in the shaft, Fig. 46-53. While driving in check to make sure that the thrust washers are fitted properly.
- Rotate the gears so that the grease is evenly distributed on them.
- Fit the differential housing in a vice. Check the backlash with a rocker indicator, Fig. 46-54. The clearance may be max. 0.22 mm (0.0088"). If the backlash is greater than this, replace the thrust washers for the differential side gears. Washers are available in the following sizes: 0.74, 0.78, 0.82, 0.86, 0.90, 0.94 and 0.98 mm (0.029, 0.030, 0.032, 0.033, 0.035, 0.037").



Fig. 46-52. Fitting the diff. side gears

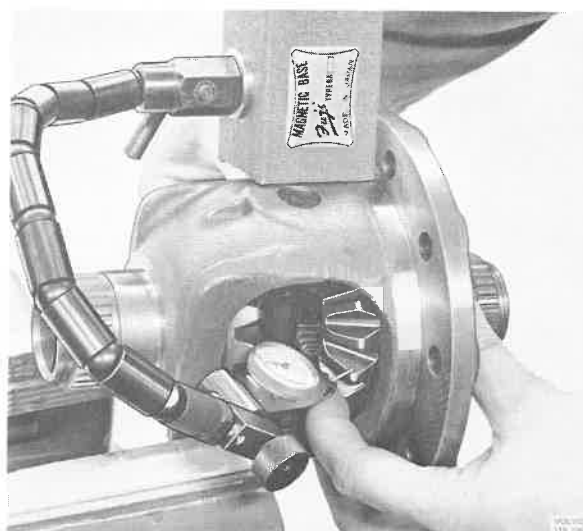


Fig. 46-54. Checking the clearance



Fig. 46-55. Pressing on the bearing

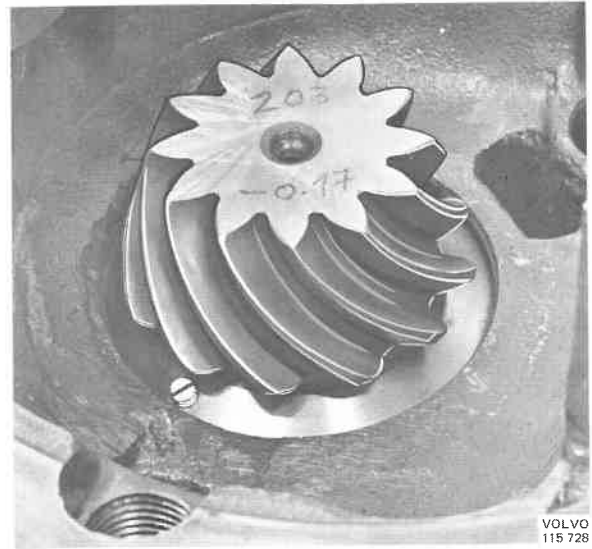


Fig. 46-57. Lock bolt

7. When correct backlash has been obtained, drive in the shaft lock pin.
8. Press on the differential bearings with 6116, Fig. 46-55.
9. Fit the crown wheel. Fit and tighten the bolts to a torque of 80-100 Nm (8-10 kpm = 58-72 lbftf).

#### Assembling the rear differential carrier

Special tools: 1845, 2284, 2395, 2404, 2600, 2636, 2685, 2686, 2806, 2841, 6102, 6113, 6146.

1. Polish the pinion mesh face with a fine emery cloth.
2. Place the adjuster ring 2685 with lock screw facing the pinion. Tighten up spanner 2841, Fig. 46-56.
3. Place the pinion in the housing. The lock pin for the adjuster ring should go down into the recess on the carrier housing bearing face and the ring should be turned in order to make it easy to get at the lock bolt, Fig. 46-57.

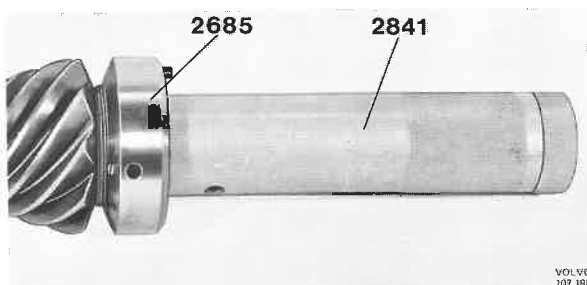


Fig. 46-56. Adjuster ring and sleeve for pinion location

4. The pinion should have a certain nominal measurement (1, Fig. 46-58) to the crown wheel centreline. Due to tolerances in manufacture, deviations from the nominal measurement arise. Deviation is indicated on the ground face of the pinion with a figure. Deviation (e.g. 1 = 0.01 mm = 0.0004") can either be + or -. To check the pinion location, use a dial indicator as well as a measuring tool 6113, which consists of two parts: a pinion gauge and an adjuster jig.

The check is carried out as follows:

Place the pinion gauge on the pinion face and the adjuster jig in the differential bearing seats, see Fig. 46-59. Screw tight parallel block 6146 on the differential carrier housing, Fig. 46-60. Place the indicator holder 2284 on the carrier housing and zero-set the indicator to the highest point on

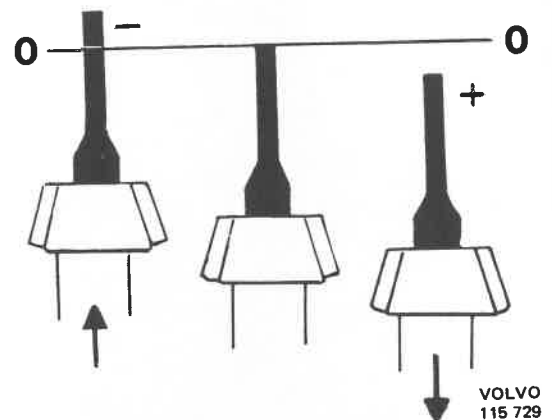
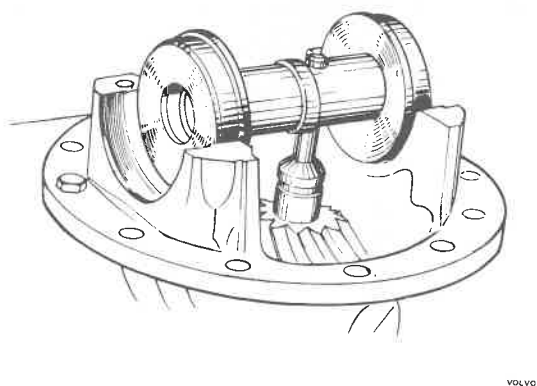
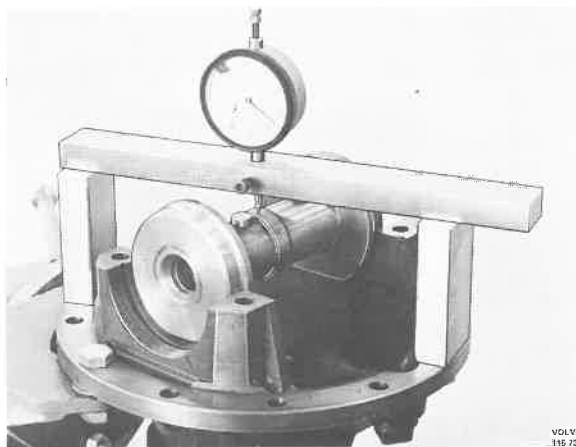


Fig. 46-58. Pinion location



VOLVO  
115 730

Fig. 46-59. Checking the location



VOLVO  
115 722

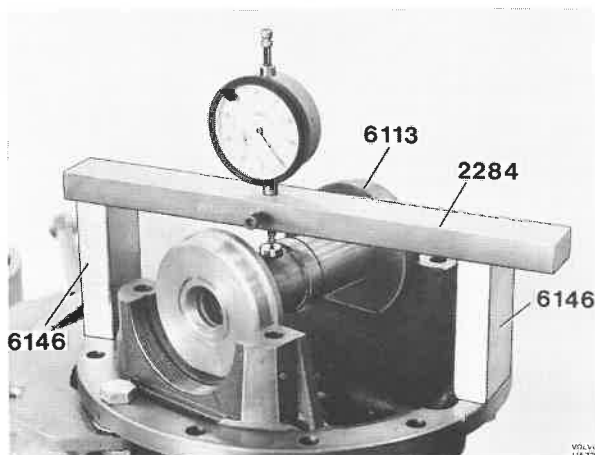
Fig. 46-61. Checking the location

the adjuster jig, Fig. 46-60. Then turn over the indicator holder so that the indicator comes towards the pinion gauge, Fig. 46-61. Read off the indicator.

If the pinion is marked 0, the adjuster jig and pinion gauge should be at the same height, if it is marked - then the pinion gauge should be higher than the adjuster jig, and if it is marked +, then the pinion gauge should be lower than the adjuster jig for correct adjustment. This is adjusted by turning the spanner on the pinion until the dial indicator shows correct value. Then lock the adjuster ring with the lock bolt. Remove the measuring tool and pinion. Remove the adjuster ring and the spanner from the pinion.

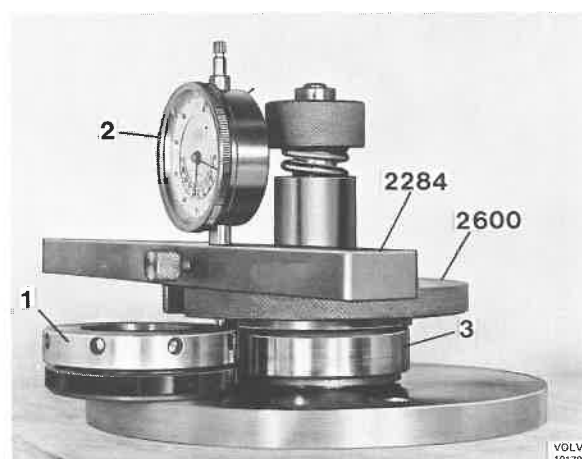
5. Place the rear pinion bearing with outer race in measuring fixture 2600. Fit on the plate, spring and nut. Turn the nut until the flat side faces

downwards. Rotate the plate (and thereby the bearing) back and forth several times so that the rollers take up their proper positions. Place the adjuster ring on the fixture, Fig. 46-62. Use holder 2284 and a dial indicator. Point the dial indicator pointer towards the bearing outer race and zero-set the indicator. Then place the pointer to point to the adjuster ring. The indicator will now indicate the thickness of shims required. NOTE! It is not always possible to obtain shims with precisely the right thickness. However, they must not be more than 0.03 mm (0.0012") thicker than the measured value but up to 0.05 mm (0.0020") thinner. Shims are available in the following dimensions: 0.08, 0.13 and 0.25 mm (0.0032, 0.0052 and 0.0098").



VOLVO  
115 728

Fig. 46-60. Checking the location



VOLVO  
101796

1. Adjuster ring 2. Dial indicator 3. Bearing, complete

Fig. 46-62. Determining shim thickness

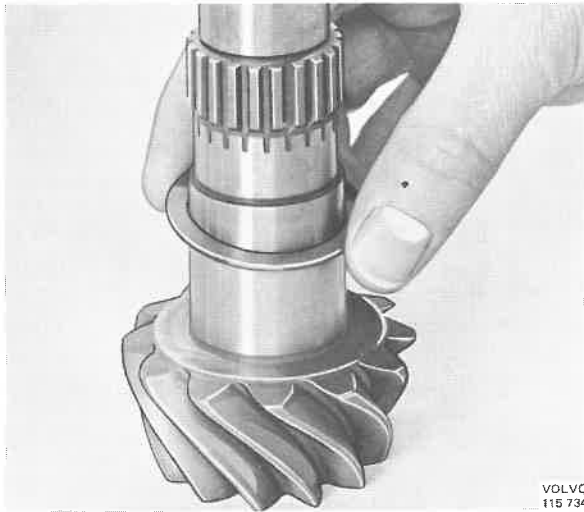


Fig. 46-63. Installing shims

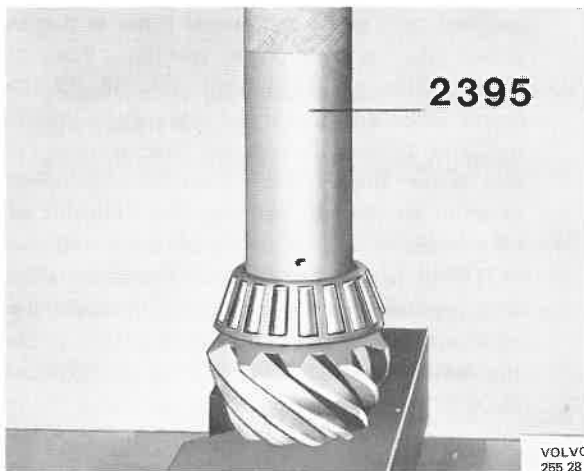


Fig. 46-64. Pressing on the bearing



Fig. 46-65. Pressing in the bearing

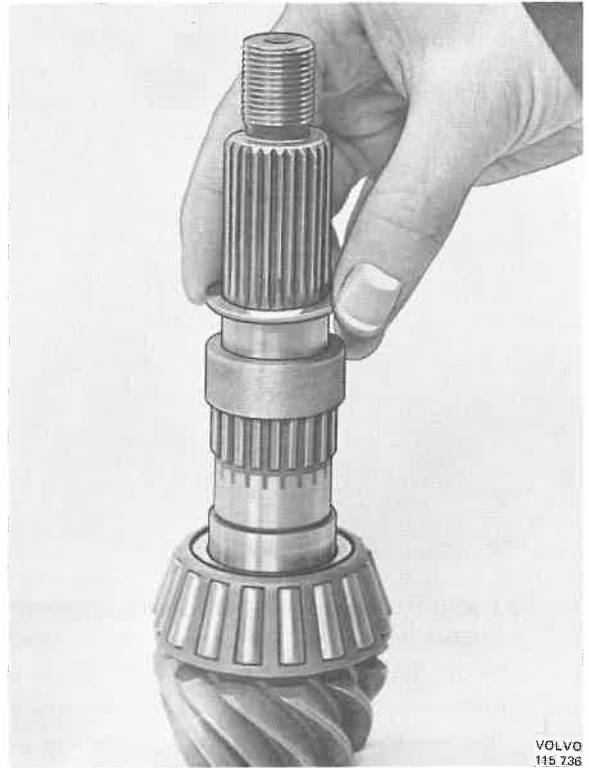


Fig. 46-66. Fitting the spacer ring

6. Place the requisite number of shims on the pinion, Fig. 46-63. Press on the bearing with 2395, Fig. 46-64.
7. Press in the rear pinion bearing outer race with 2686, Fig. 46-65.
8. Separate the tool and press in the front bearing outer race.

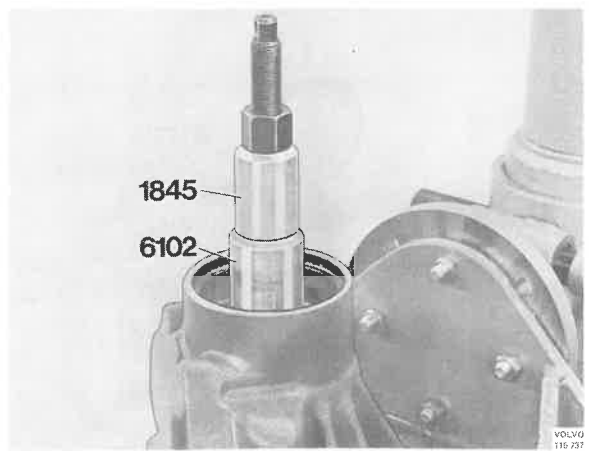


Fig. 46-67. Pressing on the bearing

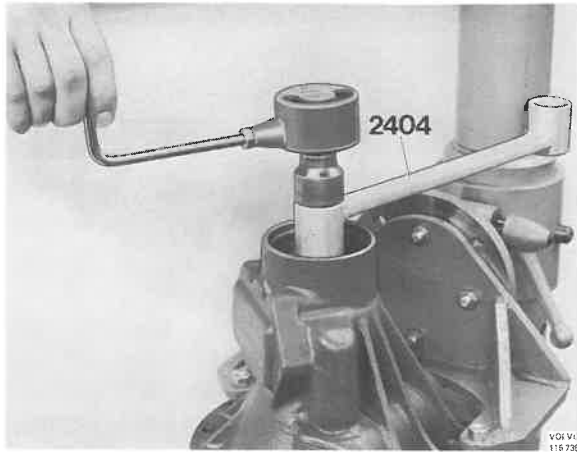
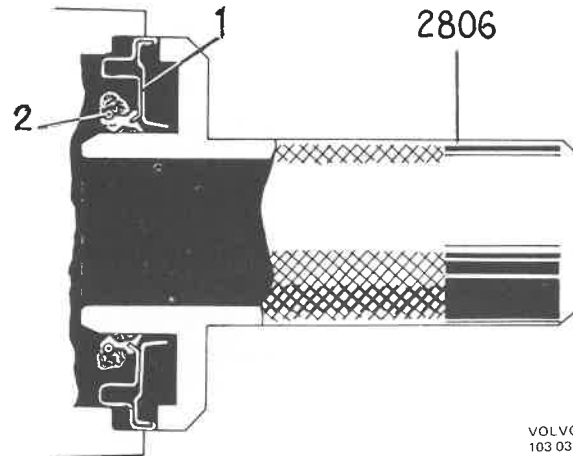


Fig. 46-68. Fixing the tool



1. Sealing ring
2. Spring with layer of grease

Fig. 46-69. Placing the grease

VOLVO  
103 031

9. Place the spacer sleeve and the shims on the pinion, Fig. 46-66. Use those shims which were removed during the disassembling plus a shim of 0.5 mm (0.020").
10. Turn the carrier. Place the pinion in the housing. Place the front bearing, sleeve 6102 and press tool 1845 on the pinion, Fig. 46-67. Pull in the bearing.
11. Remove the press tool and the sleeve. Fit 2404 on the pinion and tighten with the pinion nut, Fig. 46-68. Tighten the nut to a torque of 280-300 Nm (28-30 kpm = 202-217 lbftf).
12. Turn the carrier. Place a dial indicator on the pinion measuring face. Rotate the pinion while pulling it out at the same time. Zero-set the indicator when the pointer is at its outer position. Push in the pinion while rotating it at the same time. Read off the amount the pinion is pressed in.
13. Remove the dial indicator.  
Turn the carrier. Remove the press tool and the sleeve from the pinion. Drive out the pinion with a plastic mallet.
14. The shims on the pinion should be reduced with the axial clearance obtained plus 0.06-0.08 mm (0.0024-0.0032") for new bearings and 0.04-0.06 mm (0.0016-0.0024") for old bearings.
15. Fit the pinion with the correct number of shims according to point 14. Place the sleeve 6102 and press tool 1845 on the pinion, pull in the bearing. Remove the sleeve and the press tool.
16. Fit the spanner 2404 and the flange nut. Tighten the nut to a torque of 280-300 Nm (28-30 kpm = 202-217 lbftf).  
Check the torque (see Fig. 46-68). It should be 0.6-2.0 Nm (0.06-0.2 kpm = 0.4-1.5 lbftf) for

run-in bearings and 1.5-3.5 Nm (0.15-0.35 kpm = 1.1-2.5 lbftf) for new bearings. If the torque wrench indicates another value than what is recommended, shims must be removed or added accordingly.

17. Check the location of the pinion according to point 4.
18. Remove the flange nut and spanner.
19. Place the oil deflector plate on the front bearing. Fill 1/4 of the space between the lips with grease. See Fig. 46-69. Drive in a new seal with 2806, Fig. 46-70.
20. Fit the flange with counterhold 2837. Press on the flange with 1845, Fig. 46-74.

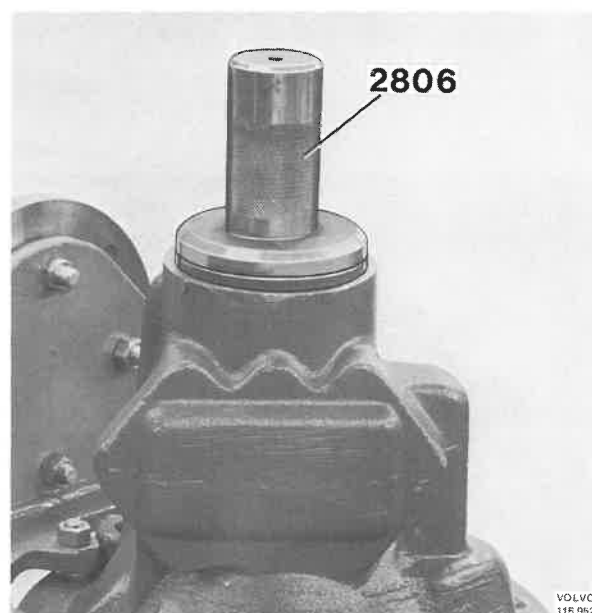


Fig. 46-70. Driving in the seal

VOLVO  
115 962

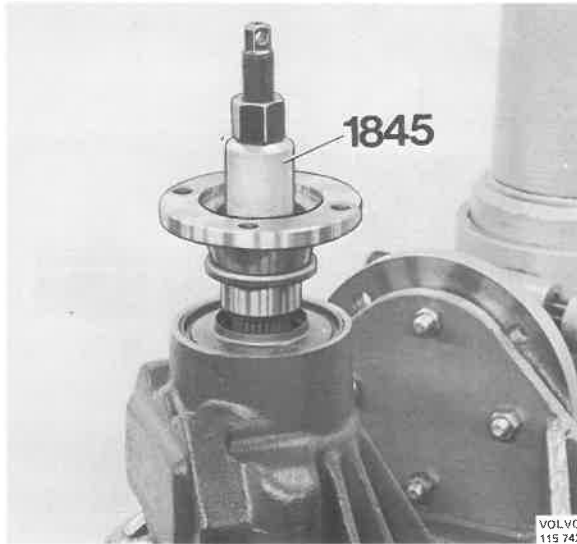


Fig. 46-71. Pressing on the flange

21. Remove the press tool. Fit the washer and the flange nut. Tighten the nut to a torque of 280–300 Nm (28–30 kpm = 202–217 lbftf). Remove the counterhold.
22. Turn the carrier. Place the spring and oil scraper in the housing.
23. Fit the differential housing in position. Oil the adjuster nuts and place them and the outer races on the housing. Check that the adjuster nuts are screwed on properly. Fit the caps, observing the line-up marks. Fit the cap bolts and tighten up. Slacken the bolts approx. 1/8 turn. Adjust the adjuster nuts so that a backlash is obtained at the same time as there is a certain clearance in the differential housing bearings.

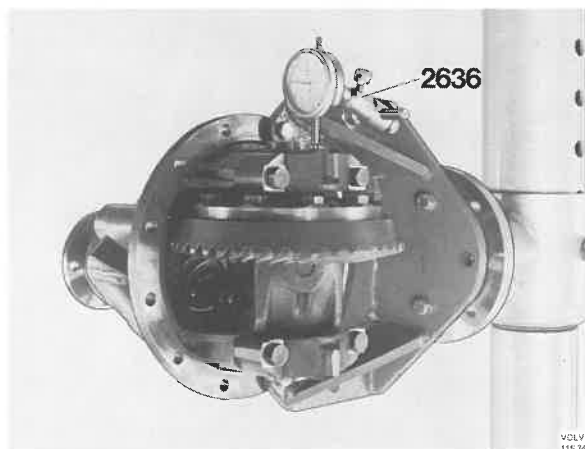


Fig. 46-72. Fixing the dial indicator

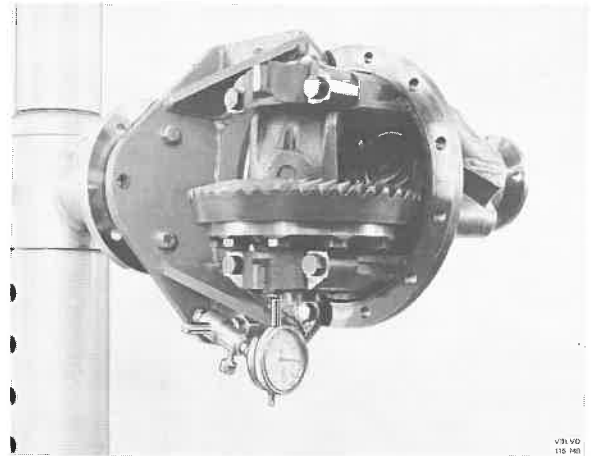


Fig. 46-73. Checking the clearance

*Adjusting the backlash and pre-loading on differential housing bearings*

1. Fix the dial indicator holder 2636 on the fixture, Fig. 46-72. Fix the dial indicator in position. Set the measuring point to the bearing inner race.
2. Turn the carrier so that the indicator faces downwards, see Fig. 46-73. Rotate the crown wheel while pressing down the differential housing at the same time. Zero-set the indicator.
3. Turn the carrier and rotate the crown wheel a couple of turns while pressing it down at the same time. Zero-set the indicator.
4. Turn the carrier and rotate the crown wheel a couple of turns. Adjust the lower adjuster nut so that the bearing clearance disappears until the indicator is again set to zero. Then turn the adjuster nut a further two notches and even more so that the lock washer can be fitted.
5. Rotate the carrier and start adjusting the backlash. Adjust with a rocker indicator. The indicator pointer is placed approx. 3 mm (0.12") from the heel of a tooth and three teeth at different places on the crown wheel are measured. The backlash may be 0.12–0.18 mm (0.0048–0.0072").  
When adjusting, turn the adjuster nuts an equal number of notches in order to maintain the correct bearing pre-loading.
6. Lock the adjuster nuts and tighten up the cap bolts to a torque of 55–67 Nm (5.5–6.7 kpm = 40–48 lbftf). Lock the bolts.

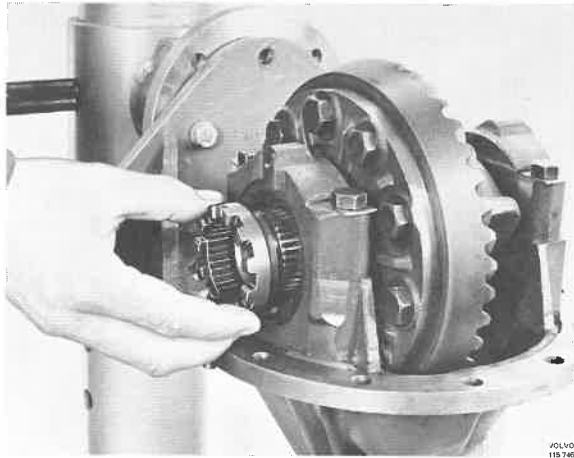


Fig. 46-74. Fitting the flange sleeve

After the carrier has been assembled and the pinion position adjusted according to the line-up marks, it is not necessary to check tooth mesh.

7. Fit the flange for the differential lock, Fig. 46-74. Fit the washer and the lock ring. Remove the carrier from the fixture.

## WHEEL CARRIERS

### Front wheel carrier

#### Removing a wheel carrier

1. Remove the wheel nuts from the wheel. Jack up the vehicle.
2. Remove the wheel.

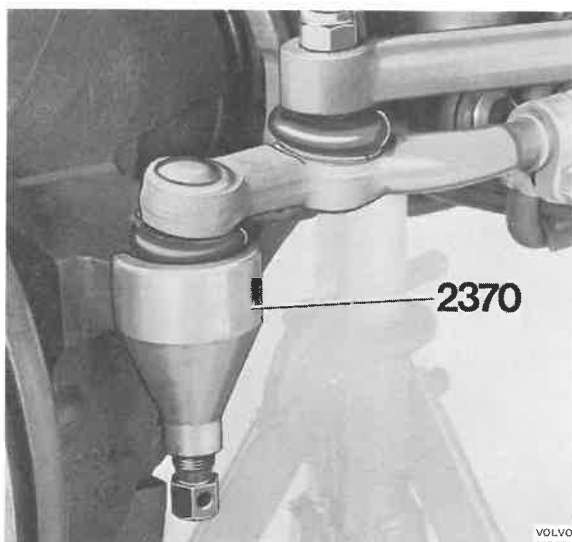


Fig. 46-75. Removing the steering rod

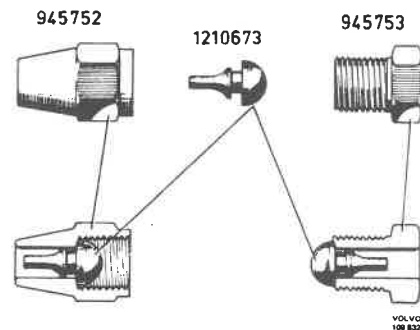


Fig. 46-76. Sealing nipples

3. Drain the oil from the wheel carrier housing. Remove the steering joint from the steering rod with puller 2370, Fig. 46-75.
4. Remove the brake lines from the brake hoses. Plug the hoses with sealing nipples, see Fig. 46-76 for a suitable nipple, Volvo part nos. 945752 + 1210673. Remove the bracket with hoses from the wheel carrier housing.
5. Remove the stop plate for the hollow rubber spring.
6. Remove the upper bolts securing the wheel carrier housing to the front axle casing. Fit the guide pin 6131 in the upper holes, Fig. 46-77. Place a jack under the wheel carrier housing.
7. Remove the lower bolts and pull out the wheel carrier housing with drive shaft.



Fig. 46-77. Removing the wheel carrier

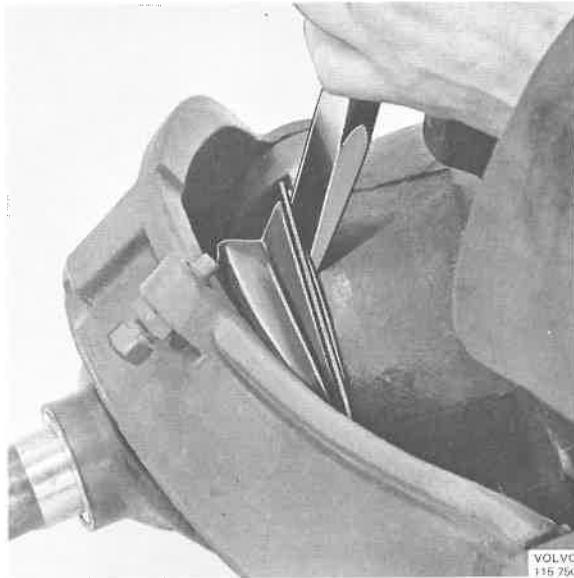


Fig. 46-78. Removing the rubber dust cover

**Replacing rubber dust cover, wheel carrier**

1. See under "Removing the front wheel carrier".
2. Remove the rubber dust cover with a suitable tool, Fig. 46-78.
3. Remove the bushing in the dust cover. If the bushing is in good condition, it can be re-fitted together with the new dust cover.
4. Check to make sure that the guide edge of the dust cover is clean. Grease the edge and the bushing.
5. Place the dust cover in position and drive it down with 6117, Fig. 46-79. **Take care not to damage the dust cover should the shaft fall against the steering knuckle support.**

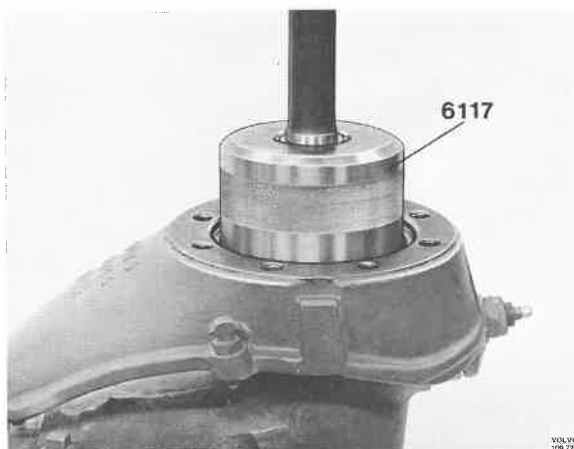


Fig. 46-79. Driving in the seal



Fig. 46-80. Removing the rubber dust cover

6. See under "Installing the front wheel carrier".

**Replacing the drive shaft joint**

1. See under "Removing the front wheel carrier housing".
2. Remove the rubber dust cover with a suitable tool, Fig. 46-80.
3. Lift the drive shaft and knock on the wheel carrier housing with a plastic mallet at the same time, Fig. 46-81.

If the shaft pin accompanies the drive shaft:

Secure the drive shaft in a vice with copper jaws or similar. Knock out the pin with a plastic mallet, see Fig. 46-82.

If the shaft pin does not accompany the drive shaft:

Fit a standard puller, see Fig. 46-83, and pull off the shaft pin.

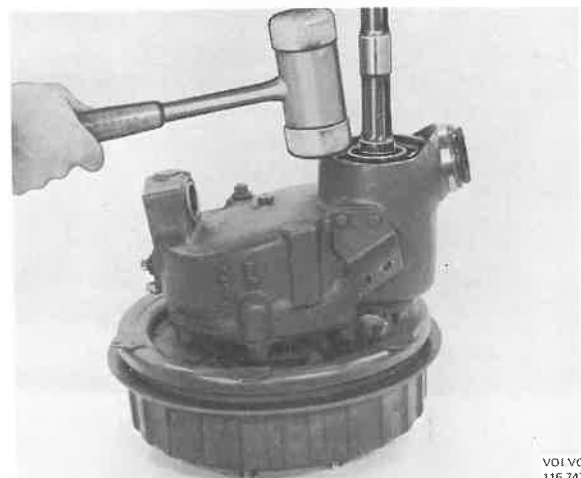


Fig. 46-81. Removing the drive shaft

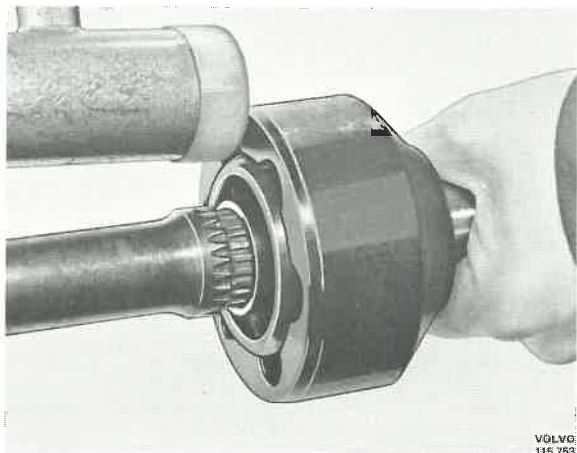


Fig. 46-82. Removing the drive shaft joint

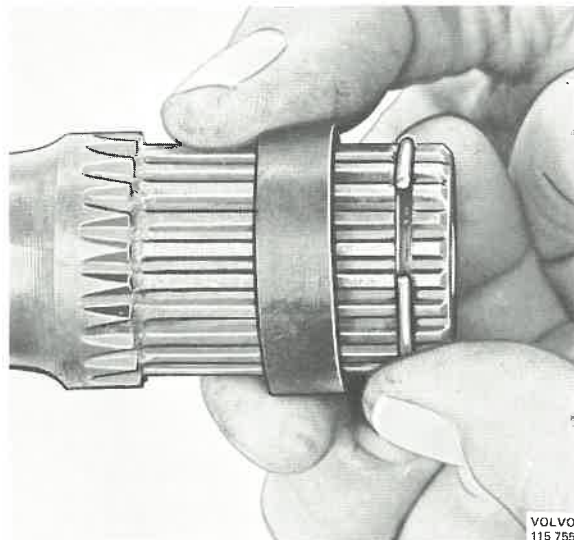


Fig. 46-84. Placing the spacer ring

4. Replace the circlip on the drive shaft and push the spacer ring over the circlip, Fig. 46-84. Grease the circlip and splines.
5. Place the shaft pin on a flat surface, Fig. 46-85, and the drive shaft in the flange. Knock on the rear end of the drive shaft so that it glides into the flange.
6. Replace the circlip on the shaft pin. Grease the circlip and splines. Place the shaft in the gear wheel of the wheel carrier. Knock down the shaft pin so that the circlip grips in the gear wheel.
7. Grease the guide edge of the rubber dust cover and bushing. Fit the dust cover over the shaft. Knock down the dust cover with 6117, Fig. 46-86.

8. See under "Installing the front wheel carrier".  
NOTE! The rubber dust cover can easily be damaged if the shaft rests against the steering knuckle support.

#### Reconditioning the drive shaft joint (removed)

The drive shaft joint can be disassembled for cleaning and checking. The components of the joint are not sold separately since, like a ball bearing which is matched with its inner and outer races, the joint parts are matched. The joint is disassembled and assembled as follows:

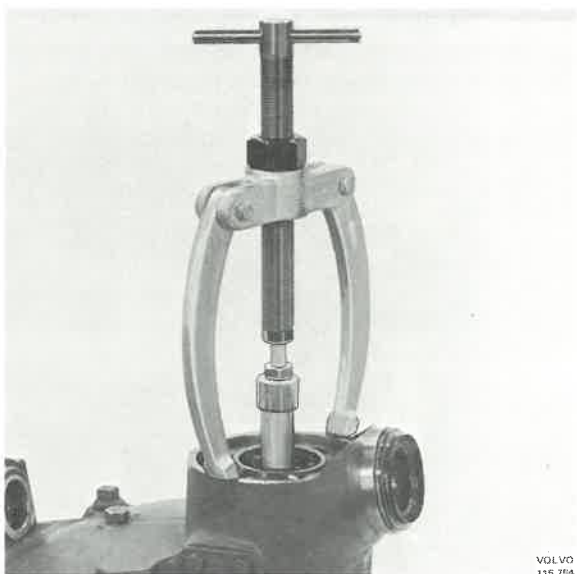


Fig. 46-83. Removing the shaft pin

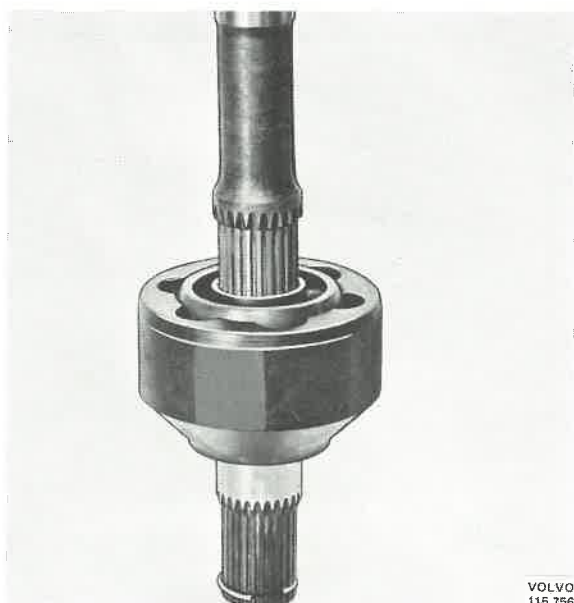


Fig. 46-85. Driving in the drive shaft

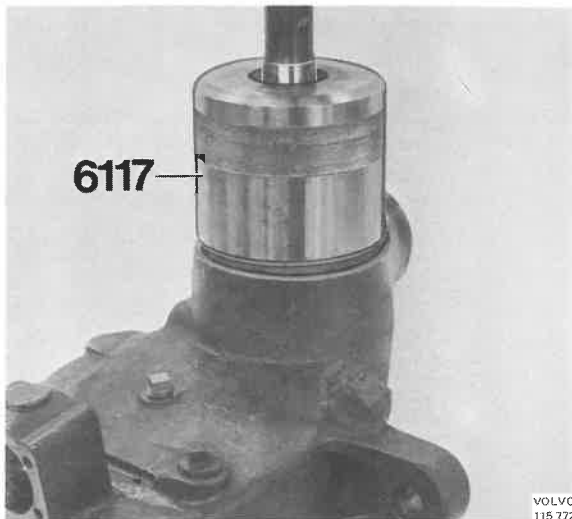


Fig. 46-86. Driving in rubber dust cover

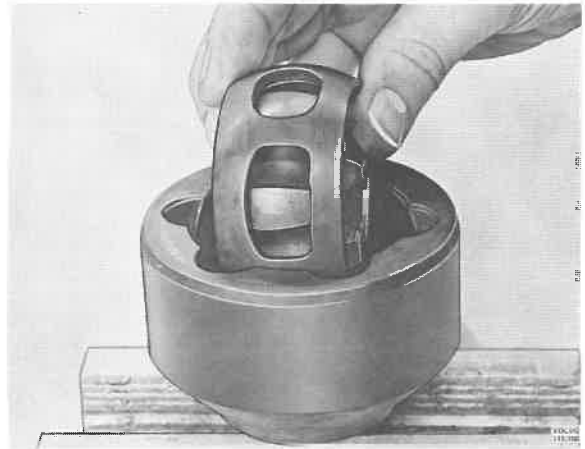


Fig. 46-89. Removing the ball cage

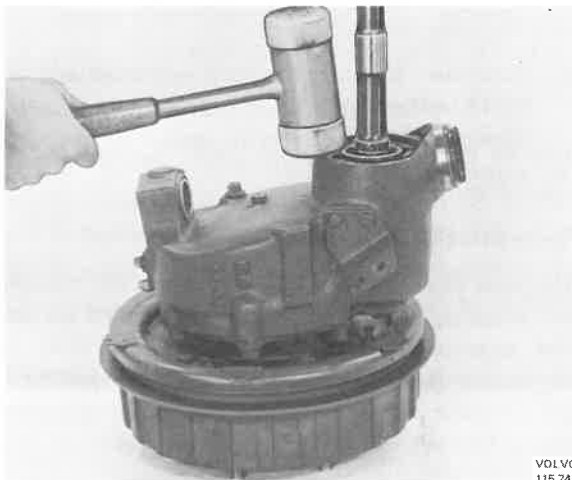


Fig. 46-87. Removing drive shaft joint

#### *Disassembling*

1. Secure the drive shaft in a vice provided with copper jaws or similar. Knock the drive shaft joint out of the drive shaft by knocking on the shaft pin, Fig. 46-87, with a plastic mallet.
2. Secure the shaft pin in a vice. Rotate the ball cage and flange so that a ball can be plucked up, Fig. 46-88. Repeat this and pluck up the remaining balls.
3. Rotate the ball cage and flange according to Fig. 46-89 and pluck it out of the shaft pin.
4. Rotate the flange according to Fig. 46-90 and take it out of the cage.

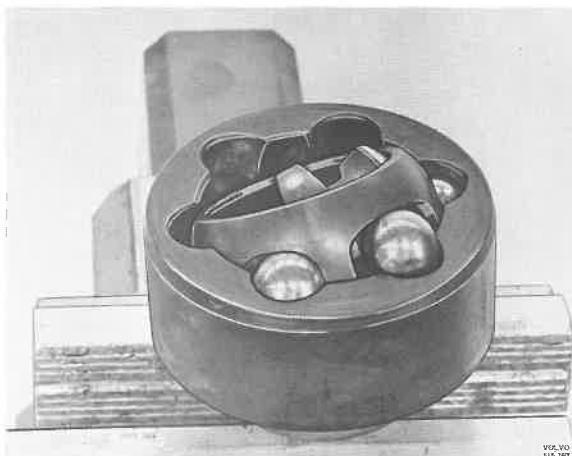


Fig. 46-88. Drive shaft joint



Fig. 46-90. Removing the flange

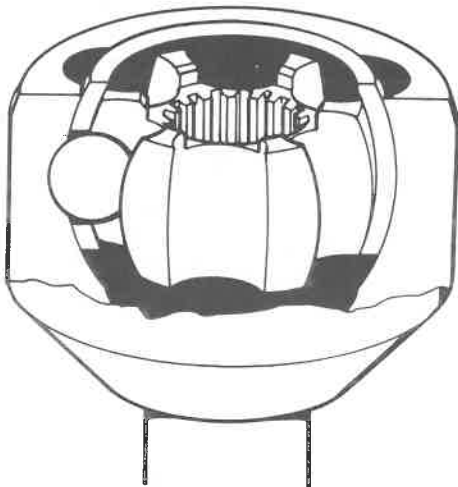


Fig. 46-91. Location of flange

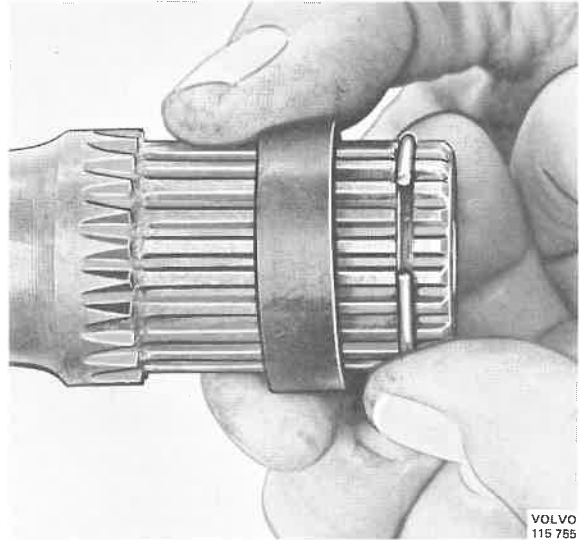


Fig. 46-92. Placing the circlip

#### Checking and replacing parts

Clean all parts and dry them thoroughly. If the balls, cage, flange or shaft pin are damaged in any way, then the shaft pin and joint must be replaced complete.

When assembling, fill the inside of the shaft pin and the parts with grease of the long-fibre type for wheel bearings, e.g., MP lubricating grease.

#### Assembling

1. Place the flange in the cage and fit them in the shaft pin.
2. Insert the balls one at a time. When all the balls have been inserted, the flat side of the flange as well as the small inner diameter of the cage, Fig. 46-91, should face downwards.
3. Replace the circlip on the drive shaft and push the spacer ring over the circlip, Fig. 46-92.
4. Place the shaft pin on a flat surface, Fig. 46-93, and fit the drive shaft in the flange. Knock on the rear end of the drive shaft so that it glides into the flange.

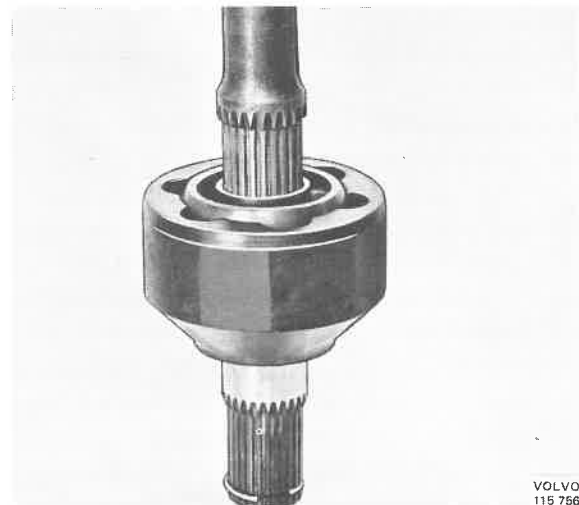


Fig. 46-93. Driving in the drive shaft

#### Reconditioning a wheel carrier (removed)

##### Disassembling

Special tools: 2413, 6141.

1. Clean the wheel carrier housing and the steering knuckle support.
2. Remove the cover for the lower steering knuckle joint. Unscrew the nut for the bolt. Push in the bolt and remove the ball shell, Fig. 46-94.

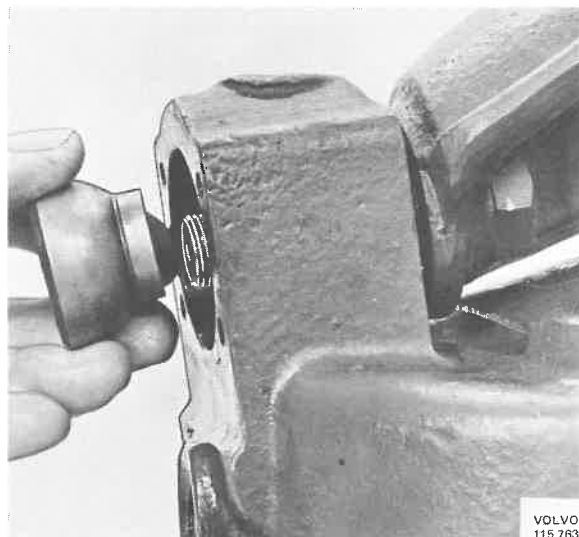


Fig. 46-94. Removing the ball shell



Fig. 46-95. Removing rubber dust cover

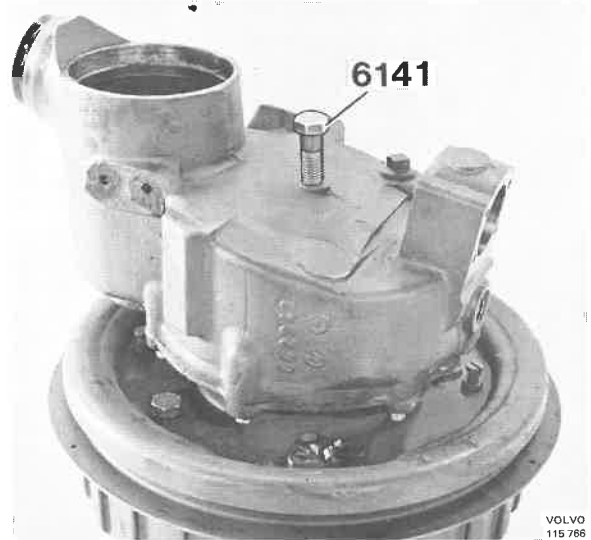


Fig. 46-97. Pressing housing apart

3. Lift off the steering knuckle support. Remove the bolt and the shims.
4. Tap loose the rubber dust cover, Fig. 46-95, with a suitable tool.
5. Remove the wheel carrier from the vice. Hold the drive shaft upwards, Fig. 46-96, and with a plastic mallet knock on the wheel carrier housing, see Fig. 46-96, so that the shaft pin releases from the gear wheel in the housing.  
If the shaft pin does not accompany the wheel carrier, it must be pulled out with a standard puller.
6. Remove the nuts securing the wheel hub housing to the wheel carrier housing. Remove the plug on

the wheel carrier housing. Fix and pull in the dismantling bolt 6141, Fig. 46-97. Remove the hub when it loosens from the final gear. Remove the bolt 6141.

7. Remove the bearing circlip from the housing.
8. Place the final gear in a press and press out the gear wheel, bearing and needle bearing at the same time with 2413, Fig. 46-98.
9. Remove the circlip on the gear wheel and press off the bearing with 2413, Fig. 46-99.

*Checking and replacing parts*

Clean all parts and also the contact surfaces thoroughly. Replace the ball and needle bearings.

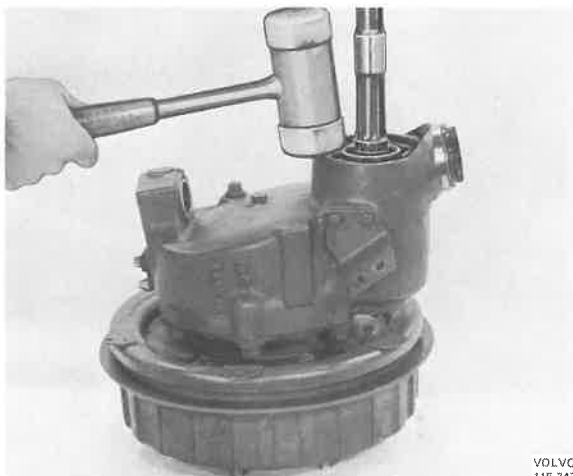


Fig. 46-96. Removing the drive shaft

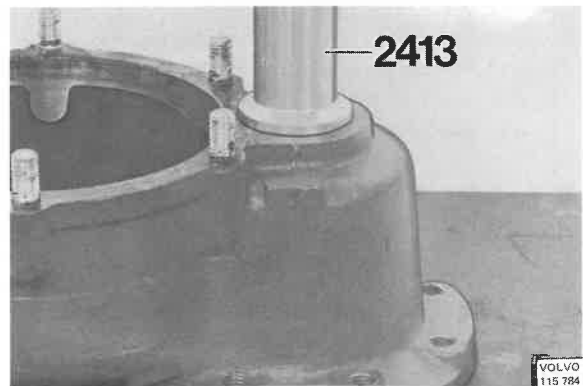


Fig. 46-98. Pressing out gear wheel



Fig. 46-99. Removing the bearing

Check the teeth on the gear wheel and if they are damaged the gear wheel should be replaced. With replacement of the gear wheel, the wheel hub should also be replaced, see special instructions under "Wheel and hub, Part 6".

Check the rubber dust cover to make sure it is not damaged. Also check the steering knuckle bolt and the ball shells for damage, see Part 6.

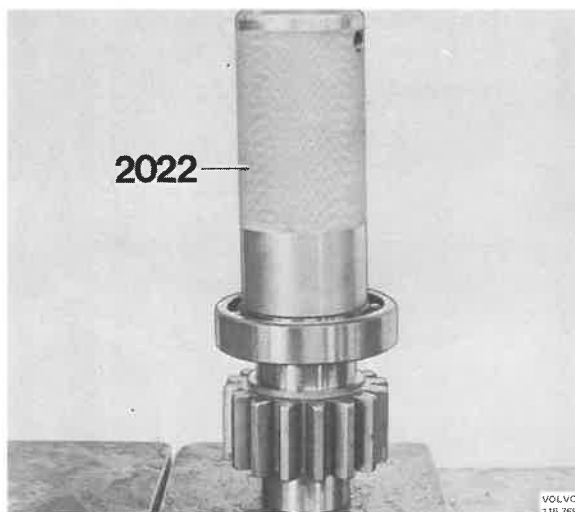


Fig. 46-100. Pressing on the bearing

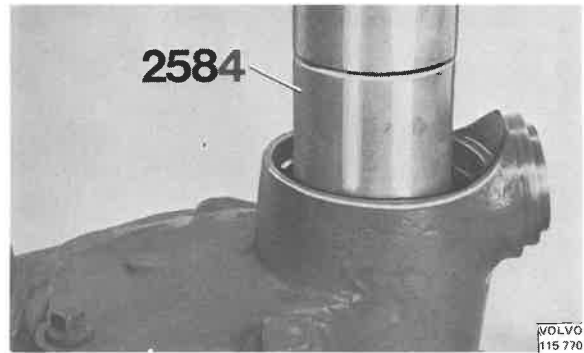


Fig. 46-101. Pressing in the gear wheel

#### Assembling

1. Press the ball bearing on the gear wheel with 2022, Fig. 46-100. Fit the circlip.
2. Press the gear wheel into the wheel carrier housing, using 2584, Fig. 46-101. Secure the circlip.
3. Oil the needle bearing. Press the bearing into the housing while rotating the gear wheel at the same time in order to make sure that the bearing is fitted properly, using 2413, Fig. 46-102. Press down the bearing so that it is flush with the edge.
4. Coat the contact surface against the hub with sealing agent. Place the hub in the housing. Fit the nuts and tighten hub and housing together.
5. Replace the circlip on the shaft pin. Grease the circlip and splines. Knock down the shaft pin so that the circlip grips in the gear wheel.



Fig. 46-102. Pressing in the needle bearing

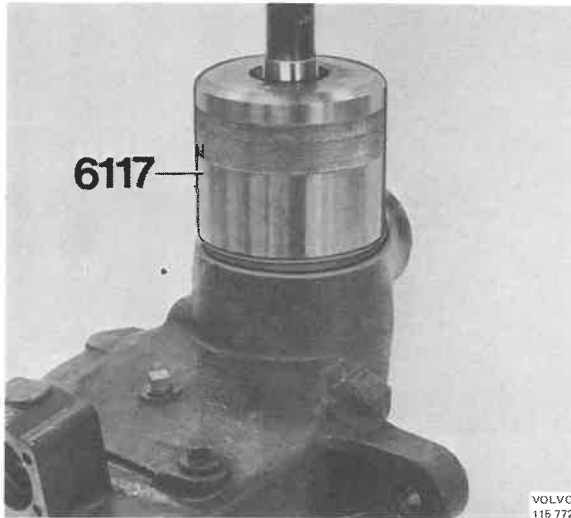


Fig. 46-103. Driving in rubber dust cover

6. Grease the rubber dust cover guide edge and bushing. Fit the dust cover over the shaft. Drive down the cover with 6117, Fig. 46-103.
7. Replace the upper seal on the wheel carrier housing, Fig. 46-104, and the seal on the support Fig. 46-105. Fit the support on the wheel carrier housing.
8. Fit the lower bolt in position. Place the same number of shims on the bolt that was removed during disassembling. Fit the ball shell in position, Fig. 46-106. Fit the nut and tighten it to a



Fig. 46-104. Fitting the seal



Fig. 46-105. Fitting the seal

- torque of 150-200 Nm (15-20 kpm = 108-145 lbftf).
9. Fit the lower cover.

#### Installing a wheel carrier

1. Clean the contact surface on the shaft casing and coat it with sealing agent.
2. Fit the two guide pins 6131 in the upper holes of the steering knuckle support. See Fig. 46-107. Place the wheel carrier on a jack. Jack up the carrier so that the guide pins can fit into the front axle casing.



Fig. 46-106. Installing the ball shell

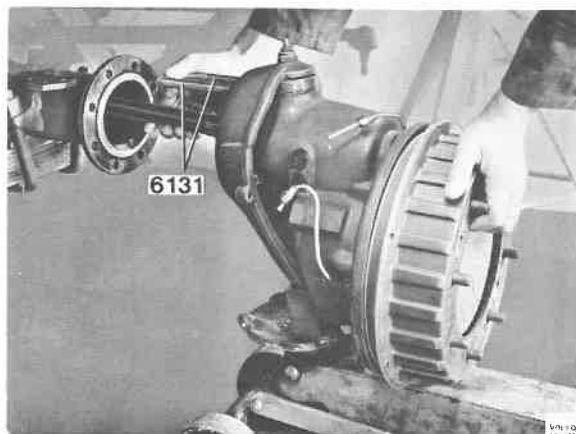


Fig. 46-107. Fitting the wheel carrier



Fig. 46-109. Tighten the bolts

**NOTE!** Check that the rubber dust cover for the drive shaft is in good condition and is fitted properly in the steering knuckle support, Fig. 46-108 before it is fitted entirely in position.

Lift up the drive shaft while pushing in the carrier at the same time. When the drive shaft comes in contact with the differentials, rotate the differential carrier flange while pushing the wheel carrier to the bottom at the same time.

3. Fit the bolts round the front axle casing. Remove the guide pins. Tighten the bolts to a torque of 100-120 Nm (10-12 kpm = 72-87 lbftf). Use 6135, Fig. 46-109. Remove the jack. Fit the bracket for the brake pipes on the front axle casing.
4. Connect the hoses to the brake pipes. Fit the bracket for the hoses on the wheel carrier housing.

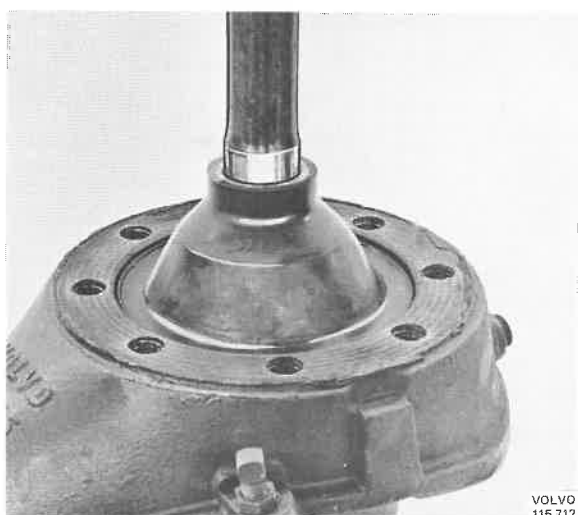


Fig. 46-108. Checking rubber dust cover

5. Fit the plate for the hollow rubber spring.
6. Check that the lower lubricating nipple is not damaged. Fit the steering rod.
7. Bleed the wheel cylinders. The pressure-difference contact should be removed before bleeding, see Fig. 46-110. If a bleeder unit is used, the working pressure should be 0.2 MPa (2 kp/cm<sup>2</sup> = 28 lbf/in<sup>2</sup>). For more detailed instructions about bleeding, see Part 5.
8. Fill the carrier with oil. Concerning quantity and quality, see under "Data".
9. Fit the wheel.
10. Lower the vehicle. Tighten the wheel nuts to a torque of 210 Nm (21 kpm = 152 lbftf).

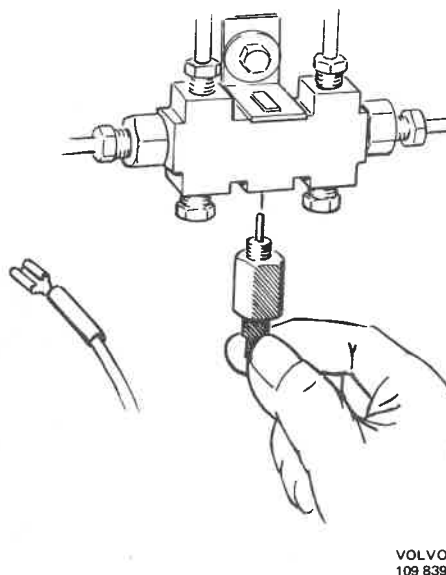


Fig. 46-110. Removing the contact

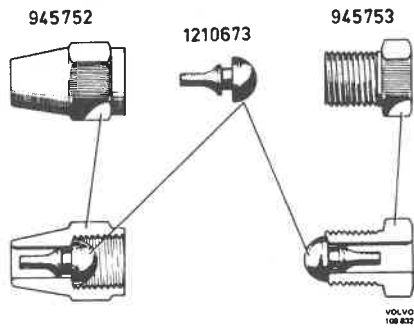


Fig. 46-111. Sealing nipple

### Rear wheel carrier

#### Removing a wheel carrier

1. Remove the wheel nuts. Jack up the rear of the vehicle.
2. Remove the wheel.
3. Drain the oil from the carrier.
4. Remove the shock absorber from its lower anchorage. Disconnect the brake pipe from the brake backing plate. Plug the pipe with sealing nipples. Concerning a suitable nipple, see Fig. 46-111. Volvo Part Nos. 945752 + 1210673.
5. Place a jack under the wheel carrier housing. Remove the bolts round the rear axle casing which secure the wheel carrier. Allow two bolts to remain. Carefully tap on the bolts so that the housing loosens from the casing.
6. Remove the bolts and pull out the wheel carrier housing with drive shaft, see Fig. 46-112.

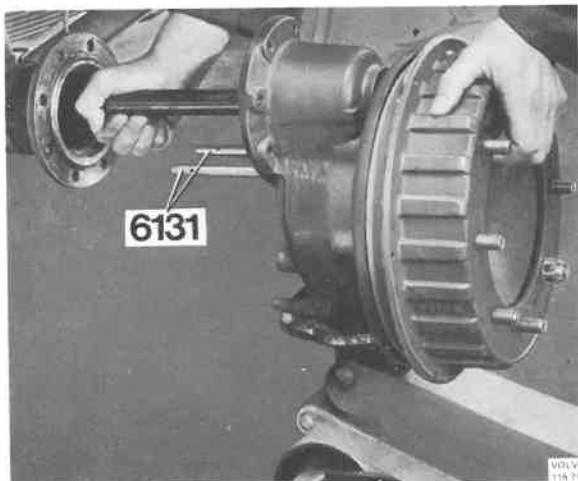


Fig. 46-112. Removing the wheel carrier

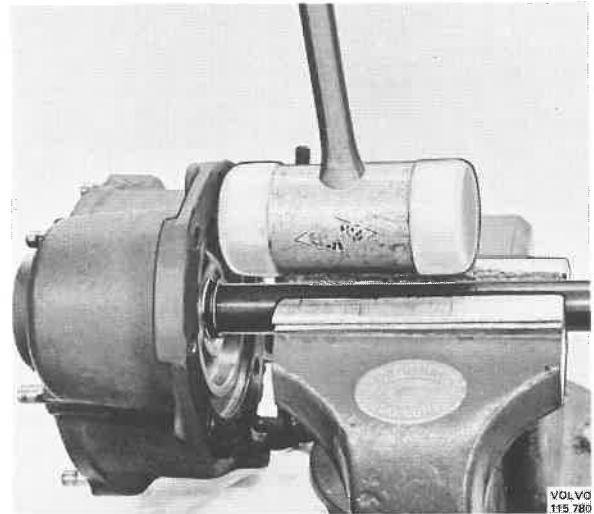


Fig. 46-113. Removing the drive shaft

#### Replacing the wear ring and seal

Special tools: 1821, 2097, 2132.

1. See under "Removing the rear wheel carrier".
2. Clean the wheel carrier housing.
3. Hold the drive shaft and with a plastic mallet knock the drive shaft and with a plastic mallet knock on the wheel carrier housing, see Fig. 46-113, so that the drive shaft releases from the gear wheel.
4. Remove the sealing wear ring with 1821, Fig. 46-114.

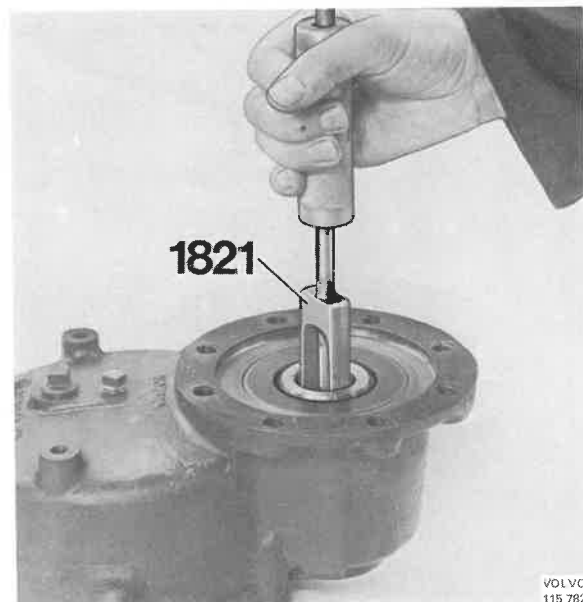


Fig. 46-114. Removing the wear ring



Fig. 46-115. Removing the seal

5. Remove the seal with 2097, Fig. 46-115.
6. Press the wear ring into gear wheel, Fig. 46-116. Grease the sealing ring surface. Press down the seal with 2132, Fig. 46-117.
7. Replace the circlip and X-ring on the drive shaft. Grease the circlip and splines. Fit the shaft in the gear wheel and drive it down so that the

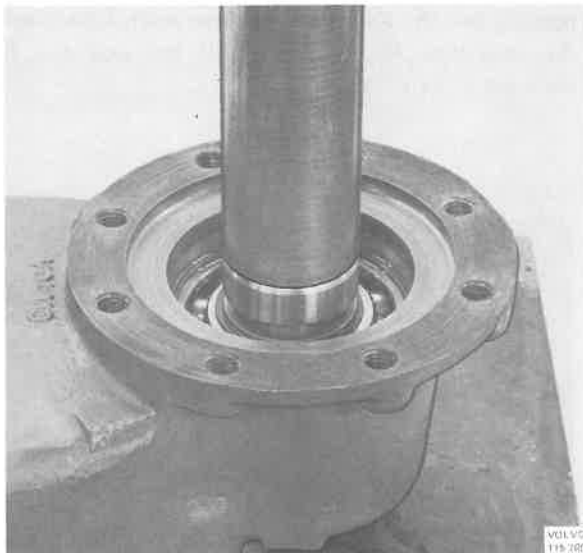


fig. 46-116. Pressing in the wear ring

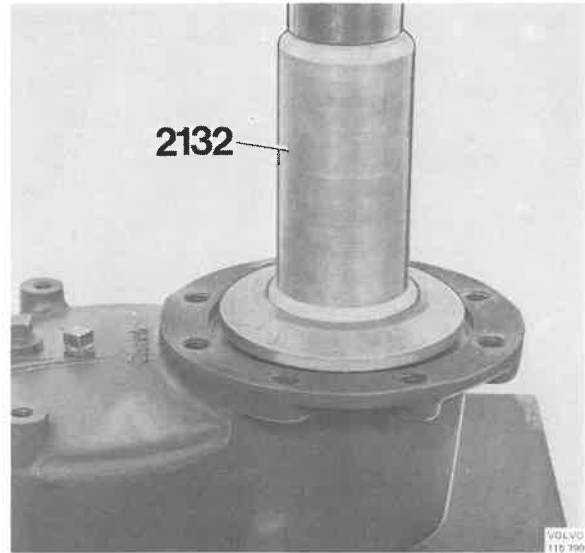


Fig. 46-117. Pressing in the seal

- circliclip grips the gear wheel. Grease the X-ring, Fig. 46-118, and press it down into the wear ring.
8. See under "Install the rear wheel carrier".

### Reconditioning the wheel carrier

#### Disassembling

Special tools: 1821, 2097, 6141.

1. Clean the wheel carrier housing.
2. Hold the drive shaft and with a plastic mallet knock on the wheel carrier housing, see Fig. 46-119, so that the drive shaft releases from the gear wheel.



Fig. 46-118. Installing the X-ring



Fig. 46-119. Removing the wear ring

3. Remove the sealing wear ring with 1821, Fig. 46-119.
4. Remove the seal with 2097, Fig. 46-120.
5. Remove the nuts securing the wheel hub housing to the wheel carrier housing. Remove the plug on the wheel carrier housing. Fit and pull in the dismantling bolt 6141, Fig. 46-121. Remove the hub when it loosens from the wheel carrier. Remove the bolt 6141.



Fig. 46-120. Removing the seal

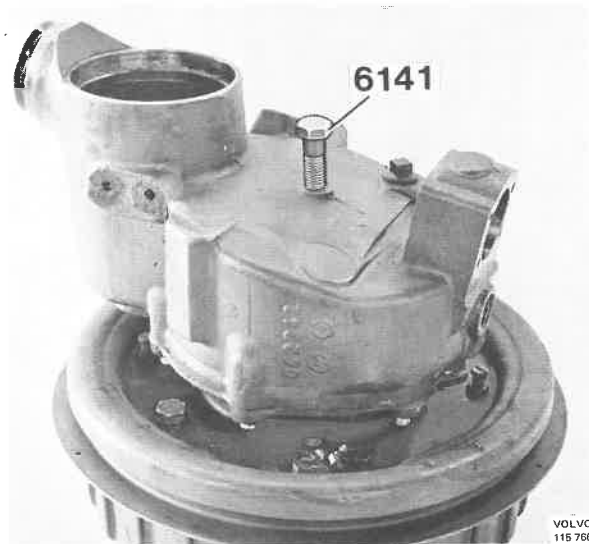


Fig. 46-121. Pressing housing apart

6. Remove the bearing circlip from the housing.
7. Place the wheel carrier in a press and press out the gear wheel, bearing and needle bearing at the same time with 2413, Fig. 46-122.
8. Remove the circlip on the gear wheel and press off the bearing with 2413, Fig. 46-123.

*Checking and replacing parts*

Wash all parts and clean the contact surfaces thoroughly. Replace the ball and needle bearings. Check the teeth on the gear wheel and if they are damaged the gear wheel should be replaced. With replacement, the wheel hub for the gear wheel should also be replaced, see special instructions under "Wheel and hub", Part 6. Replace the sealing in the housing like the X-ring on the drive shaft. Also check the wear ring for the sealing. If the wear ring is damaged, it should be replaced.

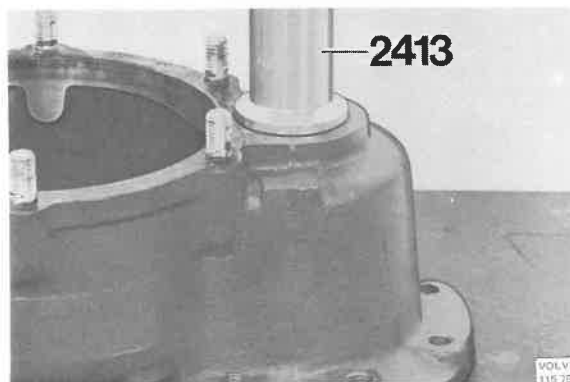


Fig. 46-122. Pressing out gear wheel



Fig. 46-123. Removing the bearing

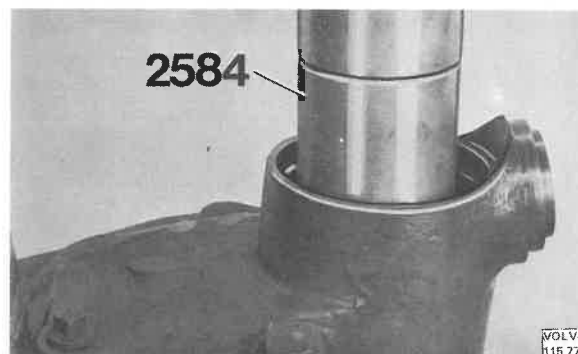


Fig. 46-125. Pressing in the gear wheel

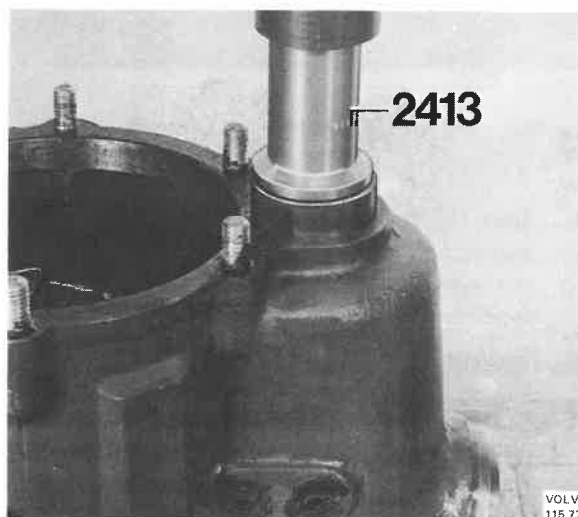


Fig. 46-126. Pressing in the needle bearing

**Assembling**

Special tools: 2022, 2132, 2413, 2584.

1. Press the ball bearing on the gear wheel with 2022, Fig. 46-124. Fit the circlip.
2. Press the gear wheel into the wheel carrier housing using 2584, Fig. 46-125. Fit the circlip.
3. Oil the needle bearing. Press the bearing into the housing and rotate the gear wheel at the same time to make sure that the bearing is fitted properly. Use 2413, see Fig. 46-126. Press down the bearing so that it comes flush with the edge.
4. Press the wear ring into the gear wheel, Fig. 46-127. Grease the sealing ring surfaces. Press down the seal with 2132, Fig. 46-128.

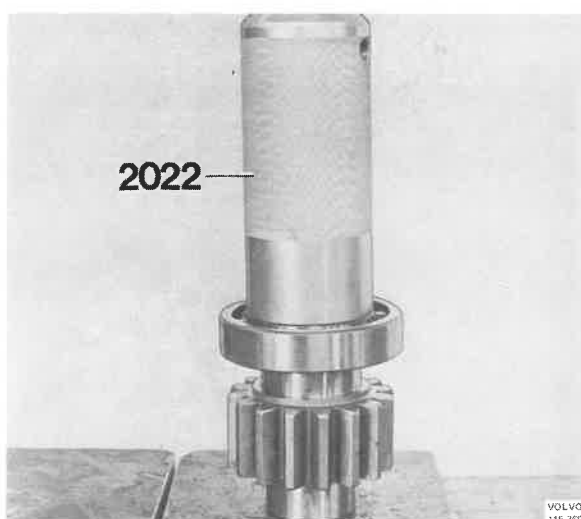


Fig. 46-124. Pressing on the bearing

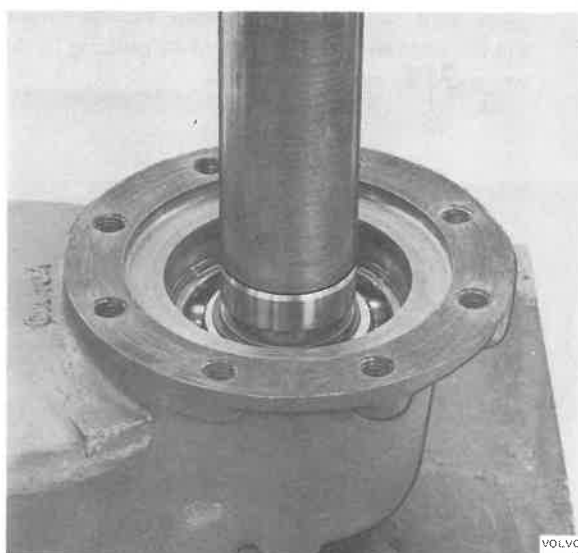


Fig. 46-127. Pressing in the wear ring

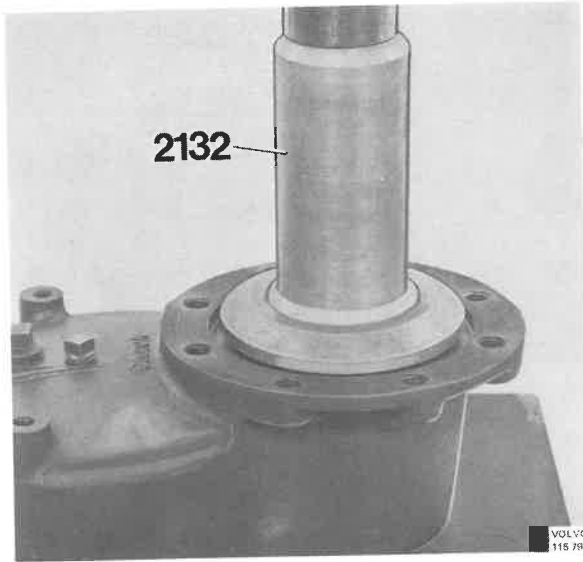


Fig. 46-128. Pressing in the seal

5. Coat the contact surface against the hub with sealing agent. Place the hub on the housing. Fit the nuts and tighten the hub and housing together.
6. Replace the circlip and X-ring on the drive shaft. Grease the circlip and splines. Fit the shaft in the gear wheel and drive it down so that the circlip grips the gear wheel. Grease the X-ring, Fig. 46-129, and press it down into the wear ring.

#### Installing the wheel carrier

1. Clean the contact surface on the rear axle casing and coat it with sealing agent.
2. Fit the two guide pins 6131 in the lower holes in the wheel carrier housing, Fig. 46-130. Place the housing on a jack. Jack up the carrier so that the guide pins can go into rear axle casing. Rotate the differential carrier flange while pushing in the wheel carrier at the same time.



Fig. 46-129. Installing the X-ring

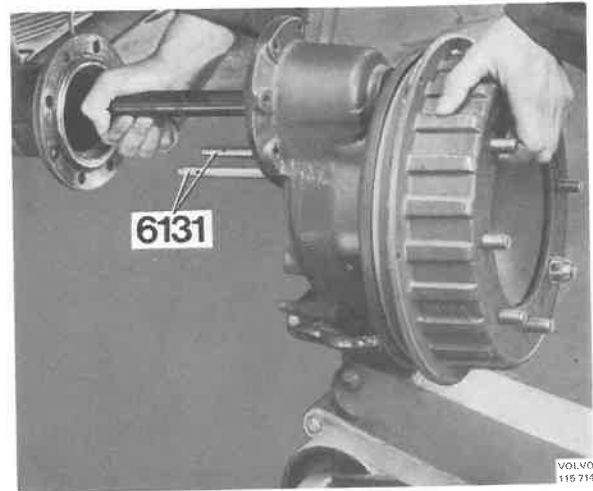


Fig. 46-130. Installing the wheel carrier

3. Fit the bolts round the casing. Remove the guide pins. Tighten the bolts to a torque of 100-120 Nm (10-12 kpm = 72-87 lbf·ft). Use 6135, see Fig. 46-131. Remove the jack.
4. Fit the shock absorber and the brake pipe.
5. Bleed the wheel cylinders. The pressure difference contact should be removed before bleeding, see Fig. 46-132. If a bleeder unit is used, the working pressure should be 0.2 MPa (2 kp/cm<sup>2</sup> = 28 lbf/in<sup>2</sup>). For more detailed instructions about bleeding, see Part 5.

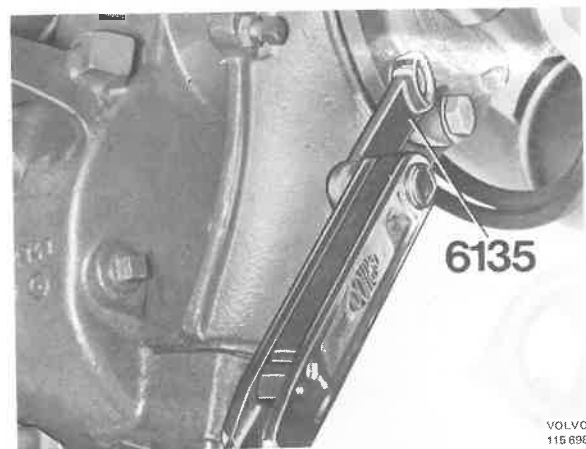


Fig. 46-131. Tighten the bolts

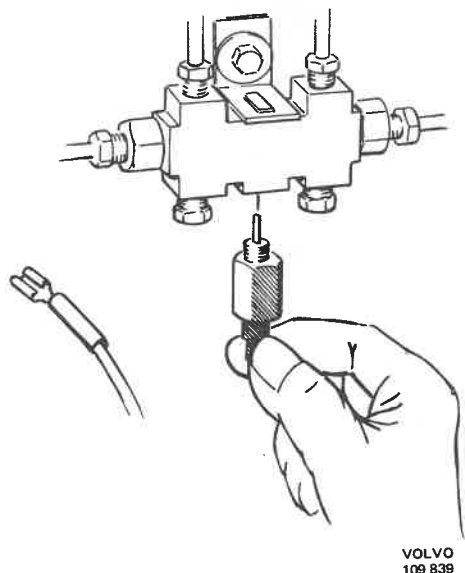


Fig. 46-132. Removing the contact

6. Fit the wheel.
7. Lower the vehicle. Tighten the wheel nuts to a torque of 210 Nm (21 kpm = 152 lbftf).
8. Fill the wheel carrier with oil. Concerning quantity and quality, see under "Data".  
Power take-off rear differential carrier.

**POWER TAKE-OFF**

**Removing the power take-off from the rear differential carrier**

1. Remove the propeller shaft.

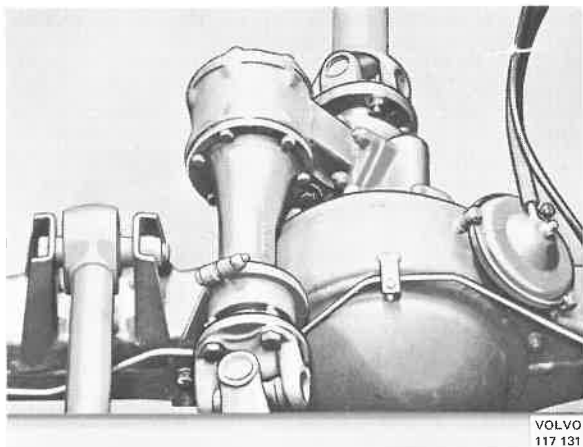


Fig 46-133 Power take-off on the differential carrier

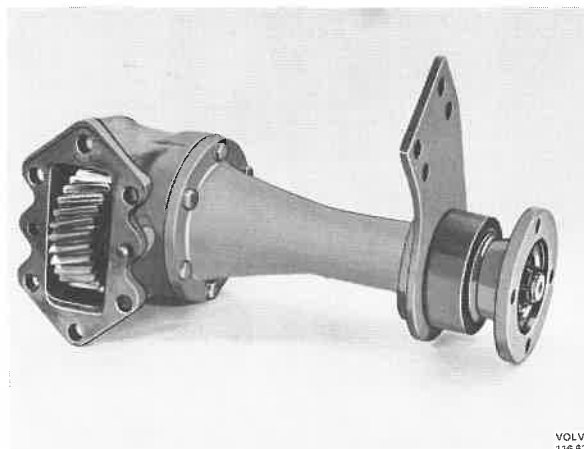


Fig 46-134 Power take-off

2. Remove the nuts securing the power-take-off to the rear differential carrier, see Fig. 46-133.
3. Remove the bolts securing the power take-off to the rear axle casing. Remove the power take-off.

Servicing the power take-off (removed)

**Disassembling**

Special tools: 1801, 2261, 2490, 2837, 4030, 6122

1. Clean the power take-off.
2. Fit it in a vice. Fit counterhold 2837 on the flange, see Fig. 46-135.  
Remove the flange nut.
3. Remove the counterhold. Remove the flange with 2261, see Fig. 46-136.

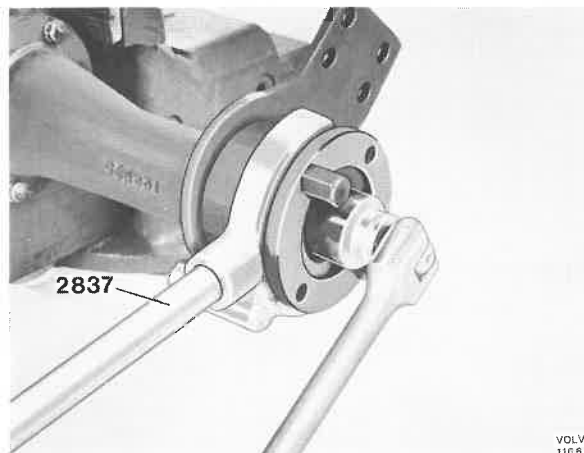


Fig. 46-135. Removing the nut

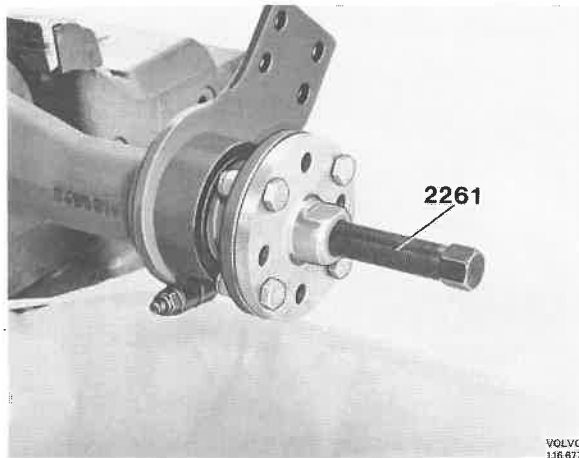


Fig 46-136 Removing the flange

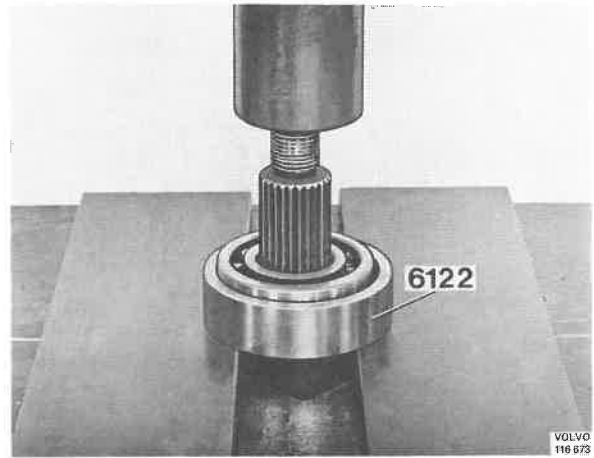


Fig 46-139 Removing the bearing

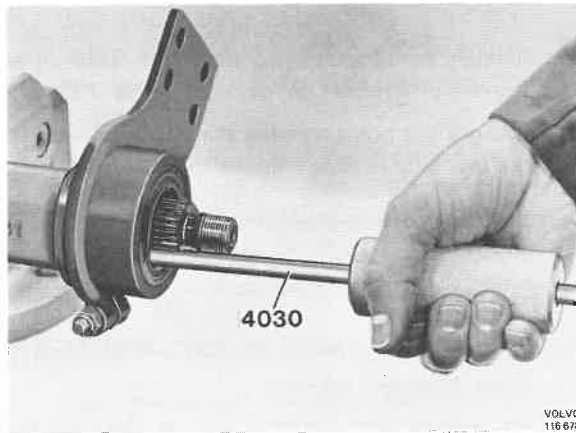


Fig. 46-137 Removing the seal

4. Remove the sealing rings with 4030, Fig. 46-137.
5. Remove the circlip holding the bearing in the housing.
6. Remove the cover on the housing for the gears. Place the power take-off in a press and press out the drive with a suitable drift, Fig. 46-138.
7. Place the drive shaft in 6122, Fig. 46-139, and press off the bearing.
8. Mark up the locating of the housing in relation to each other. Remove the bolts holding the housing together and separate the housing.
9. Remove the bolt securing the drive gear shaft. Press out the shaft with a suitable drift, Fig. 46-140. Remove the drive gear.

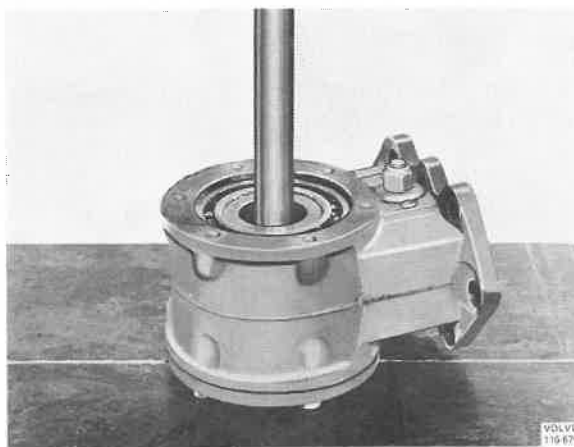


Fig 46-138 Removing the drive

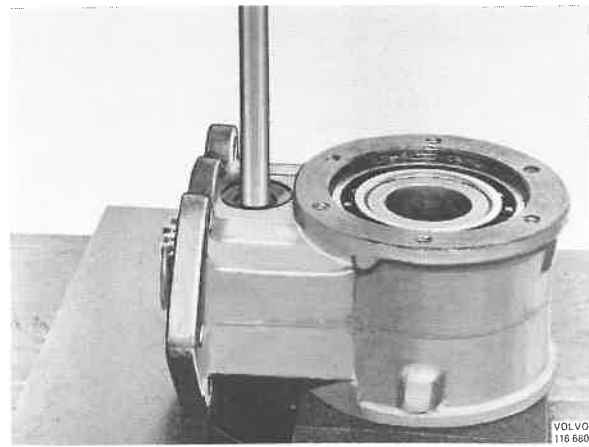


Fig 46-140 Removing the shaft

VOLVO  
116 981

Fig 46-141 Removing the races

VOLVO  
116 983

Fig 46-143 Removing the bearing

10. Remove the roller bearings and the shims from the gear. If necessary pull out the outer races with a standard puller, Fig. 46-141.
11. Press out the gear and bearing from the housing with 2490 and 1801, see Fig. 46-142.
12. Pull the ball bearings from the gear with a bearing extractor, Fig. 46-143.

### Checking and replacing parts

Clean all parts and check for damage and wear. All damaged or worn parts must be replaced. As far as seals and O-rings are concerned, they must always be replaced. When replacing a gear because of wear, always check the gear on the rear differential carrier.

### Assembling

Special tools: 2022, 2267, 2762, 6110, 6122

1. Press one of the ball bearings onto the gear with 2022, Fig. 46-144.
2. Press the gear into the housing with 2022, Fig. 46-145:

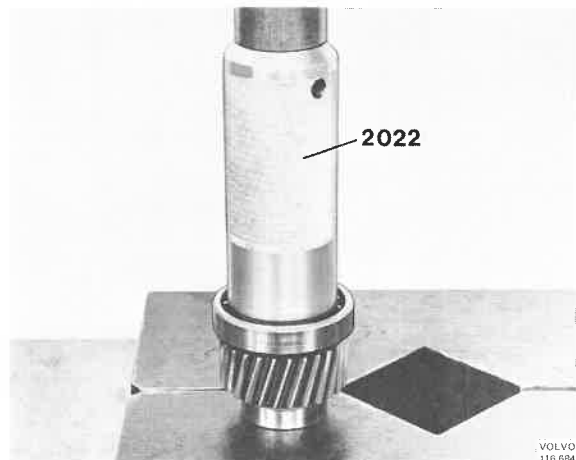
VOLVO  
116 684

Fig 46-144 Pressing on the bearing

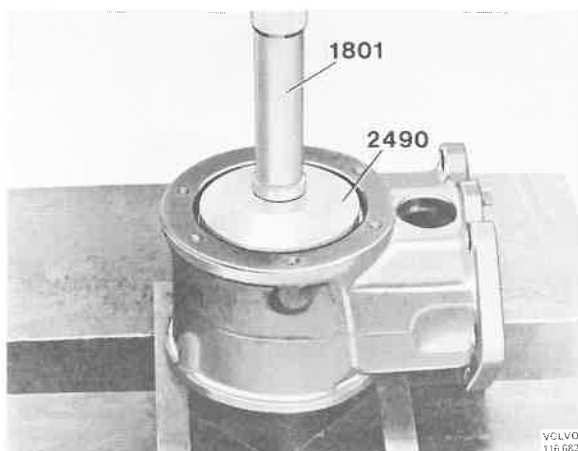
VOLVO  
116 682

Fig 46-142 Removing the bearing

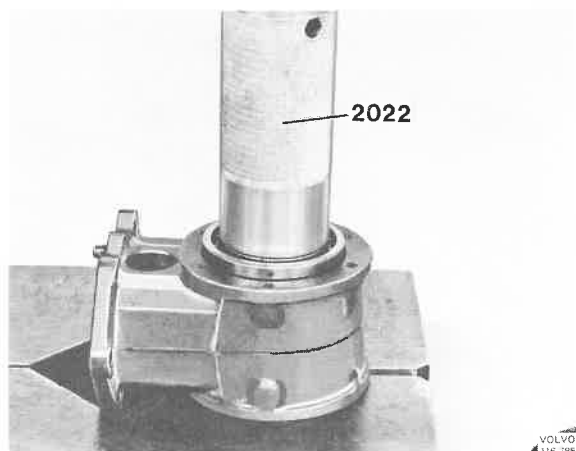
VOLVO  
116 385

Fig 46-145 Pressing in the bearing

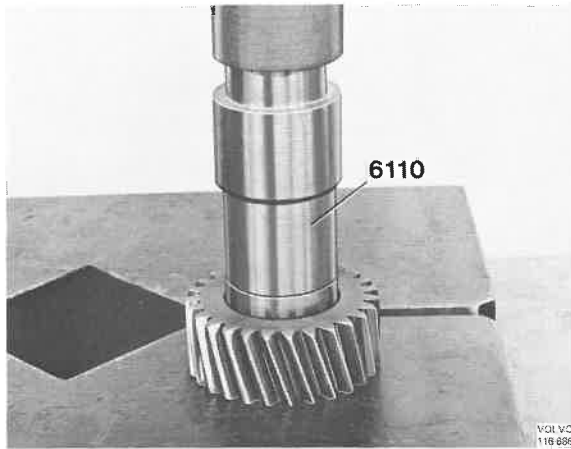


Fig 46-146 Pressing in the bearing

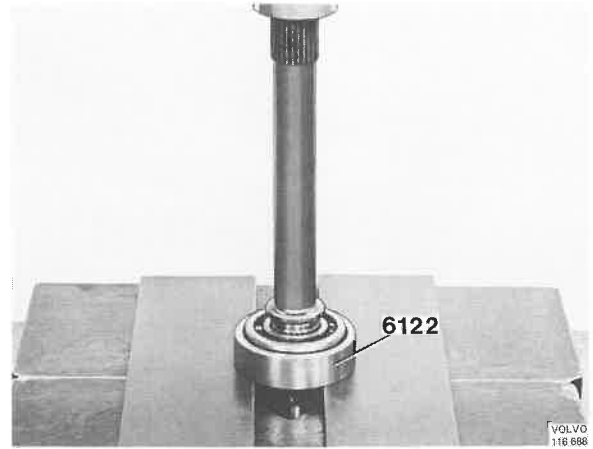


Fig 46-149 Pressing on the bearing

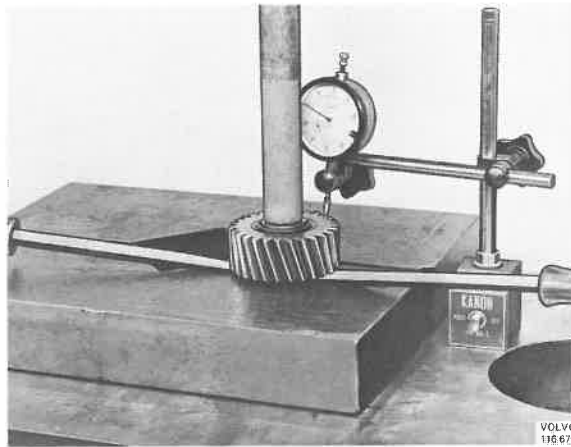


Fig 46-147 Checking the gear axial

3. Turn the housing and press the other bearings onto the gear.
4. Press the outer rings into the drive gear with 6110, Fig. 46-146.
5. Place the inner rings with the old shims in the drive gear.
6. Place the drive gear in a press, Fig. 46-147. Press the bearings together with a pressure of about 1 ton. Place a dial indicator with measuring point against the flat surface of the gear, see Fig. Check the gear axial clearance with the help of screwdrivers. The clearance must be 0.03-0.08 mm (0.012-0.032"), which is adjusted by means of shims from the following sizes: 1.25; 1.30; 1.35; 1.40; 1.60; 1.65; 1.85; 1.90; 1.95; 2.00 mm.
7. Fit new O-rings on the drive shaft.
8. Oil the drive gear bearings and place the drive gear in the housing, Fig. 46-148, and fit the shaft in position. Press in the shaft.



Fig 46-148 Fitting the gear

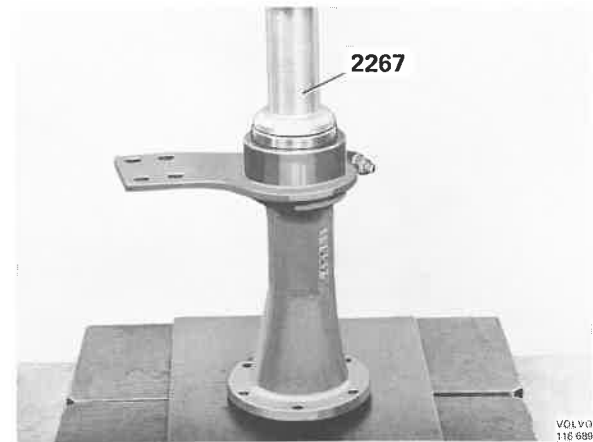


Fig. 46-150 Pressing in the drive shaft

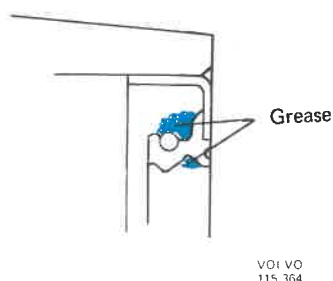


Fig 46-151 Placing grease

9. Coat the sealing surface of the housing cover with sealing agent and fit the cover.
10. Press the bearing onto the shaft with 6122, Fig. 46-149.
11. Press the drive shaft into the housing with, 2267, Fig. 46-150. Fit the circlip.
12. Fill the space between the flange seal lips to 1/4th with grease, see Fig. 46-151. Press in the seal with 2267.
13. Fit a new seal on the flange, Fig. 46-152. Grease the sealing lip. Press the flange onto the shaft with 2267, Fig. 46-153.



Fig 46-152 Flange seal

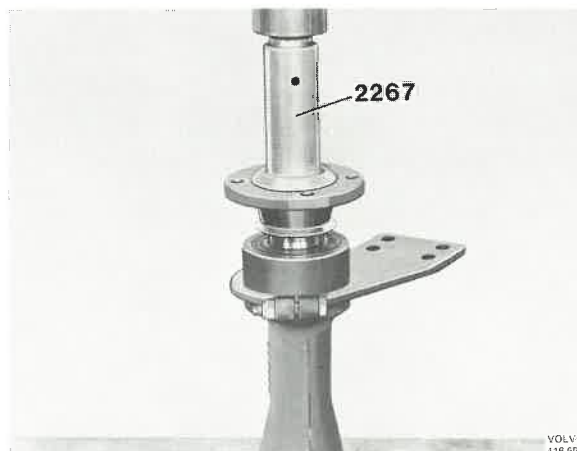


Fig 46-153 Pressing on the flange

14. Fit counterhold 2837 on the flange and fit the nut and washer. Tighten the nut to a torque of 41-51 Nm (4,1-5,1 kpm = 30-37 lbftf).
15. Coat the sealing surface on the drive shaft housing with a sealant. Place the housing and gears in the press, Fig. 46-154, and fit the drive shaft housing in position. Press the housing together. Fit the bolts and tighten up.
16. Coat the bolt head, on the bolt for the drive gear shaft, with sealing agent. Place the bolt in the shaft, and note from the flange side, see Fig. 46-155. Coat the washer with sealing agent and fit it in position. Fit the nut and tighten it to a torque of 20-25 Nm (2,0-2,5 kpm = 14-18 lbftf).

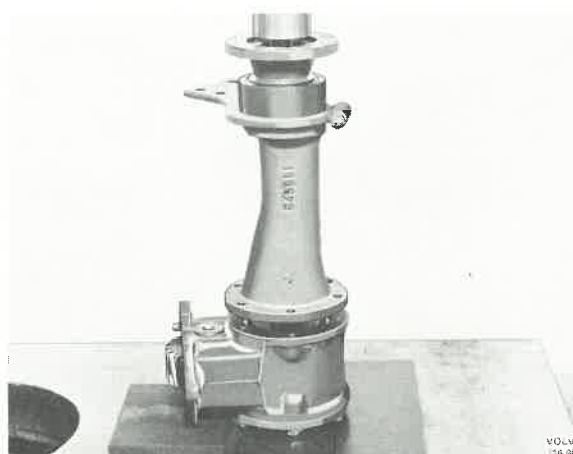


Fig 46-154 Pressing together the housing

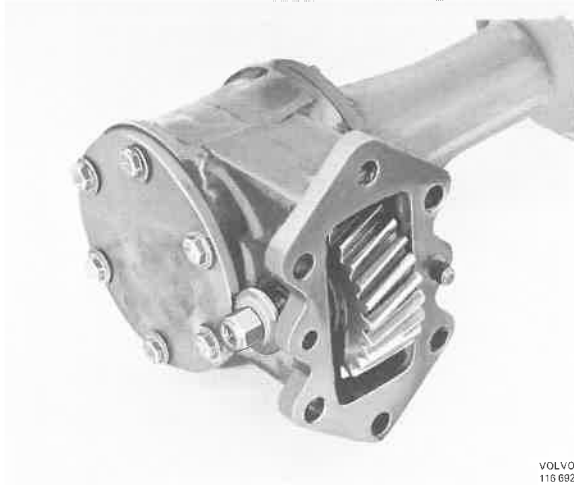


Fig. 46-155 Placing the bolt

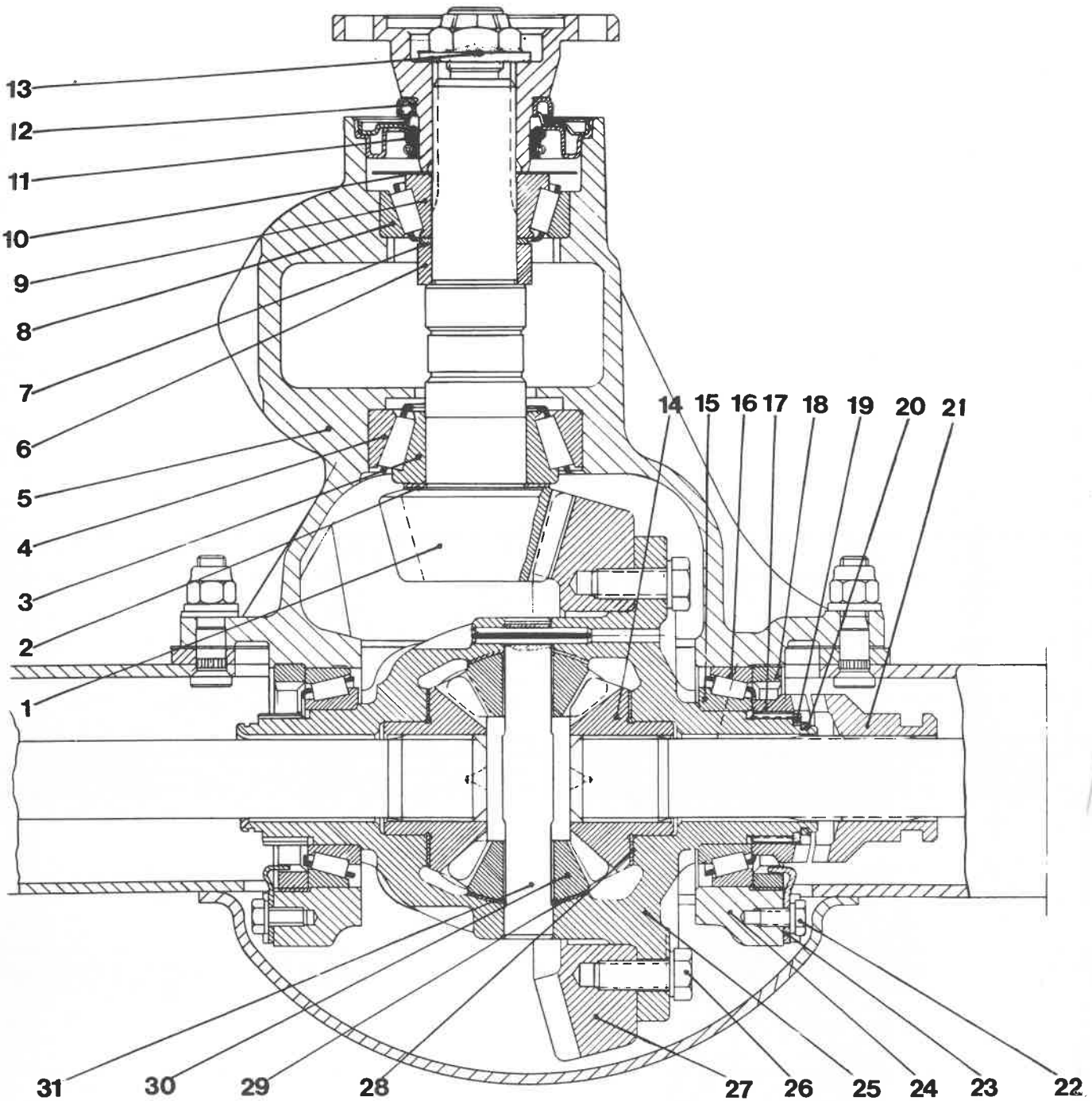
### Installing the power take-off

1. Clean the contact surface on the rear differential carrier and coat it with sealing agent.
2. Place the power take-off in position and tighten up.
3. Tighten up the propeller shaft. Tighten the bolts to a torque of 56–65 Nm (5.5–6.5 kpm = 40–48 lbftf).

**Illustration 46-A. Differential carriers**

**Differential carriers**

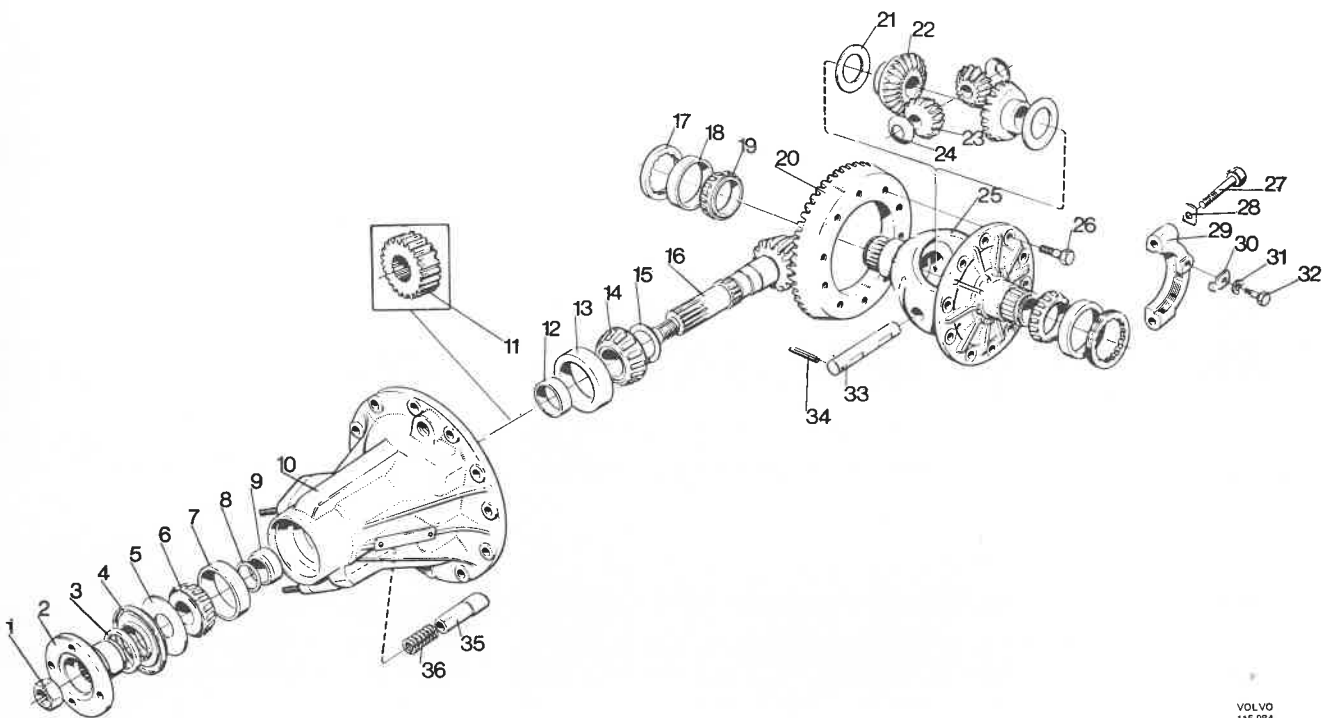
1. Pinion
2. Shims
3. Roller bearing, inner ring
4. Outer ring
5. Housing
6. Spacer ring
7. Shims
8. Outer ring
9. Roller bearing, inner ring
10. Oil deflector plate
11. Seal
12. Flange seal
13. Nut
14. Differential gear, large
15. Roller bearing, inner ring
16. Outer ring
17. Sleeve
18. Adjusting nut
19. Washer
20. Circlip
21. Flange sleeve
22. Bolt
23. Lock washer
24. Bearing cap
25. Differential housing
26. Bolt
27. Crown wheel
28. Thrust washer
29. Thrust washer
30. Differential gear, small
31. Shaft



**Illustration 46-B. Differential carriers**

**Differential carriers**

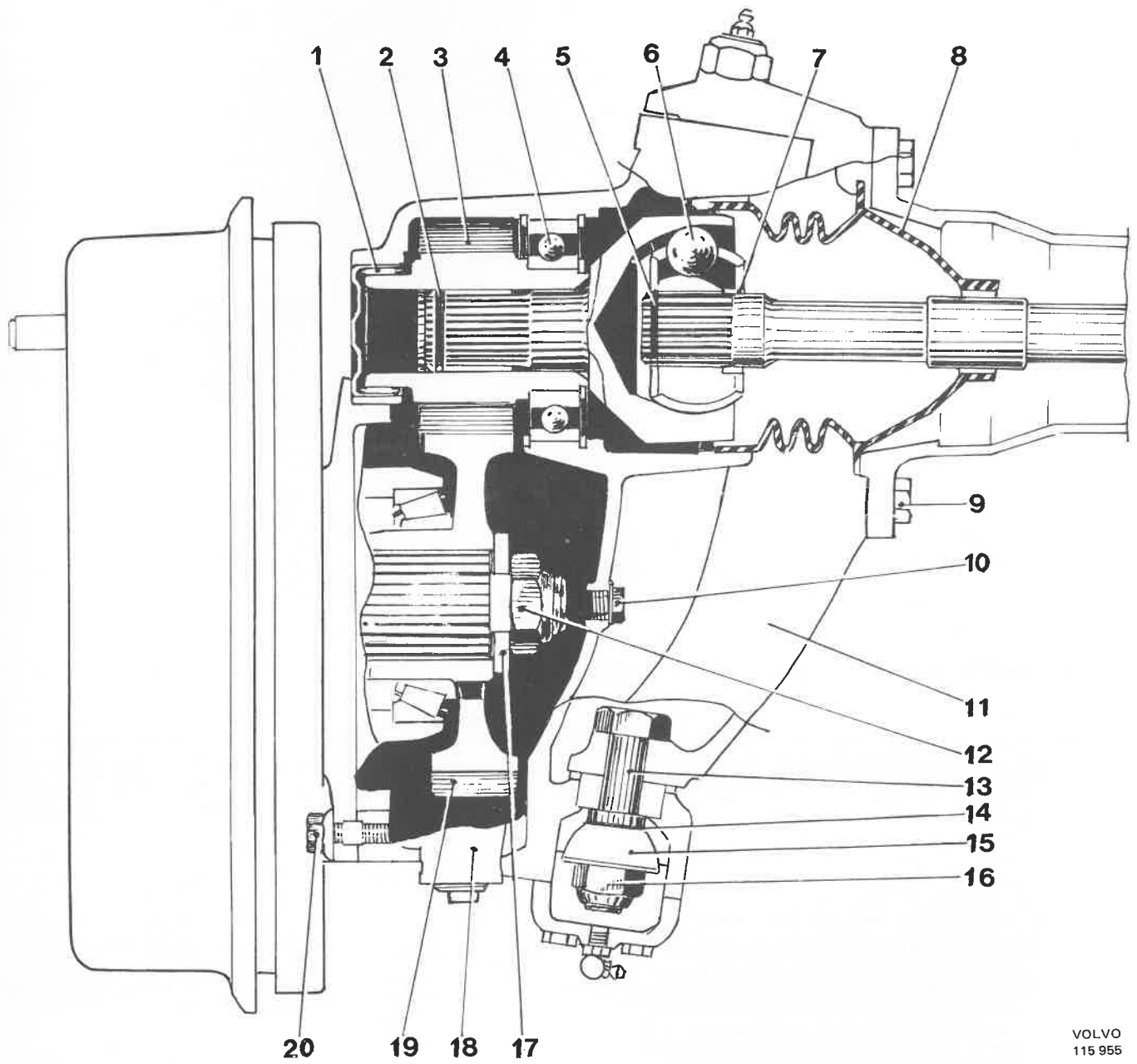
1. Nut
2. Flange
3. Flange seal
4. Seal
5. Oil deflector plate
6. Roller bearing, inner ring
7. Outer ring
8. Shims
9. Spacer ring
10. Carrier housing
11. Gear wheel (only 3-axle vehicle)
12. Spacer ring
13. Outer ring
14. Roller bearing, inner ring
15. Shims
16. Pinion
17. Adjuster nut
18. Outer ring
19. Roller bearing, inner ring
20. Crown wheel
21. Thrust washer, large
22. Differential gear, large
23. Differential gear, small
24. Thrust washer
25. Differential housing
26. Bolt
27. Bolt
28. Lock screw
29. Cap
30. Lock screw
31. Washer
32. Bolt



**Illustration 46-C. Wheel carriers front**

**Wheel carriers**

1. Needle bearing
2. Circlip
3. Gear wheel
4. Ball bearing
5. Circlip
6. Drive shaft joint
7. Spacer ring
8. Rubber bellows
9. Bolt
10. Bolt
11. Knuckle casing
12. Nut
13. Bolt
14. Shims
15. Ball shell
16. Nut
17. Washer
18. Wheel carrier housing
19. Worm gear
20. Nut

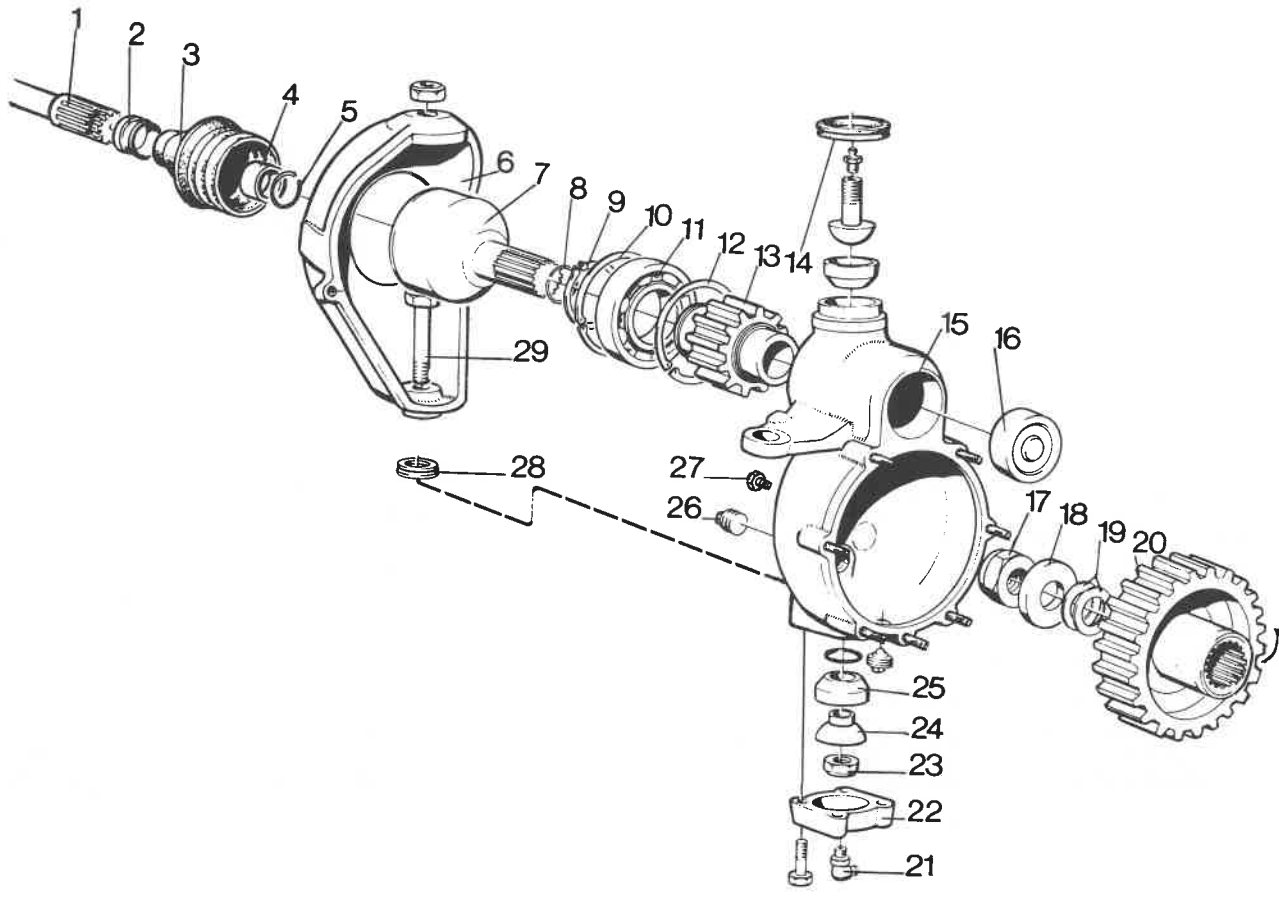


VOLVO  
115 955

**Illustration 46-D. Wheel carriers front**

**Wheel carriers**

1. Drive shaft
2. Bushing
3. Rubber bellows
4. Spacer ring
5. Circlip
6. Steering knuckle support
7. Shaft pin
8. Circlip
9. Circlip
10. Circlip
11. Ball bearing
12. Circlip
13. Worm gear
14. Sealing ring
15. Wheel carrier
16. Needle bearing
17. Nut
18. Washer
19. Shims
20. Worm gear
21. Lubricating nipple
22. Cover
23. Nut
24. Ball shell
25. Bushing
26. Plug
27. Bolt
28. Seal
29. Bolt

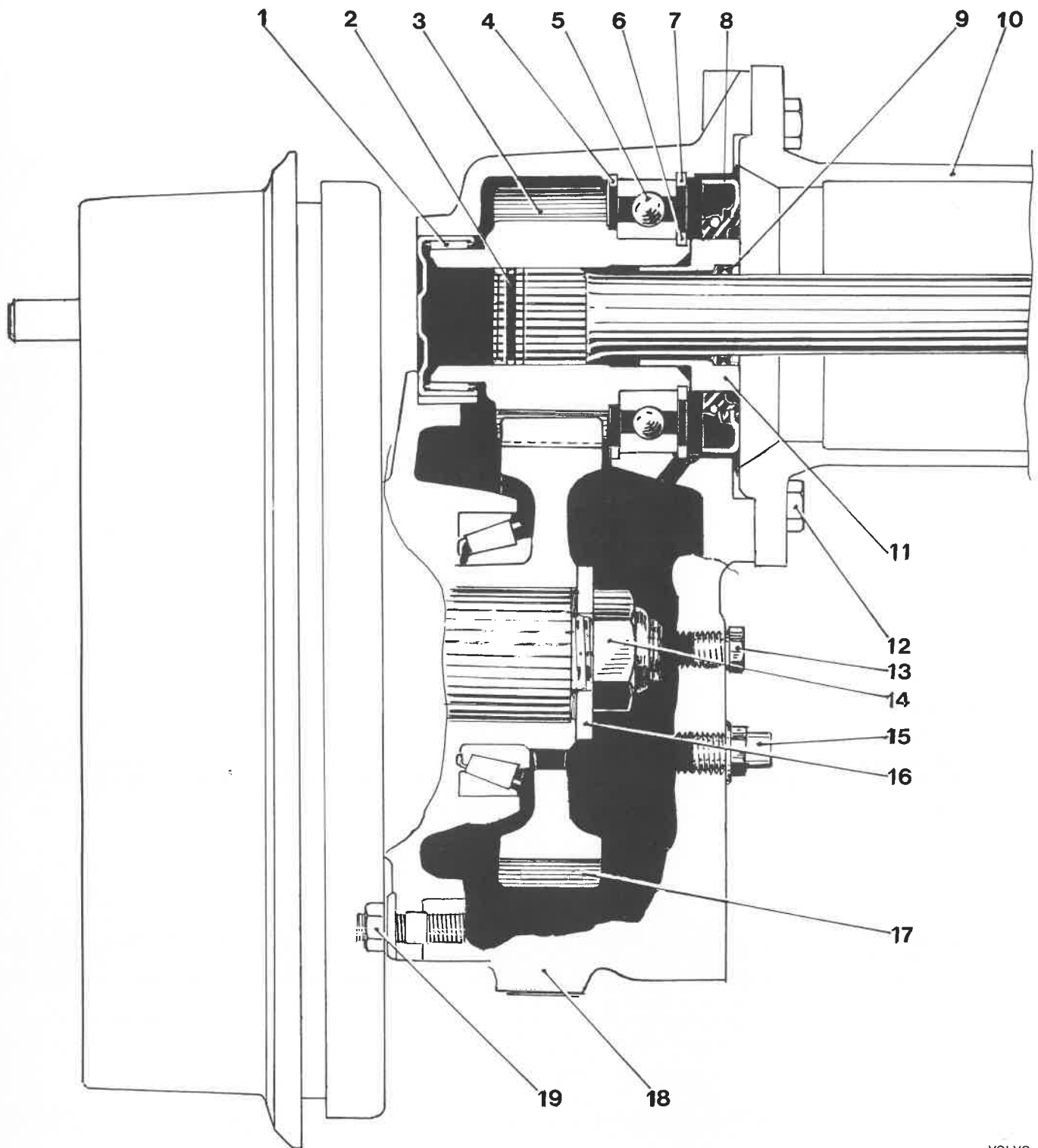


VOLVO  
115 985

**Illustration 46-E. Wheel carriers rear**

**Wheel carriers**

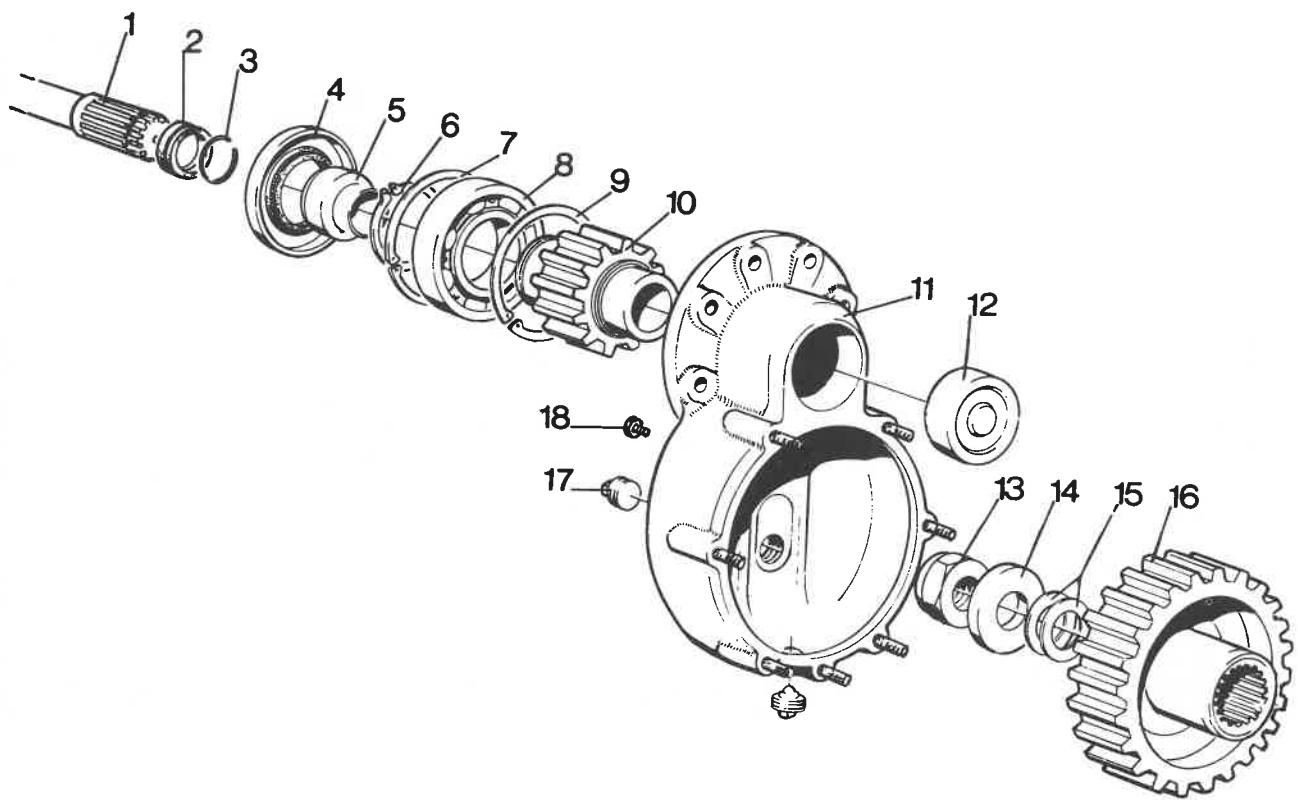
1. Needle bearing
2. Circlip
3. Worm gear
4. Circlip
5. Ball bearing
6. Circlip
7. Circlip
8. Seal
9. X-ring
10. Shaft casing
11. Wear ring
12. Bolt
13. Bolt
14. Nut
15. Plug
16. Washer
17. Worm gear
18. Wheel carrier
19. Nut



**Illustration 46-F. Wheel carriers rear**

**Waeel carriers**

1. Drive shaft
2. X-ring
3. Circlip
4. Seal
5. Wear ring
6. Circlip
7. Circlip
8. Ball bearing
9. Circlip
10. Worm gear
11. Wheel carrier
12. Needle bearing
13. Nut
14. Washer
15. Shims
16. Worm gear
17. Plug
18. Bolt

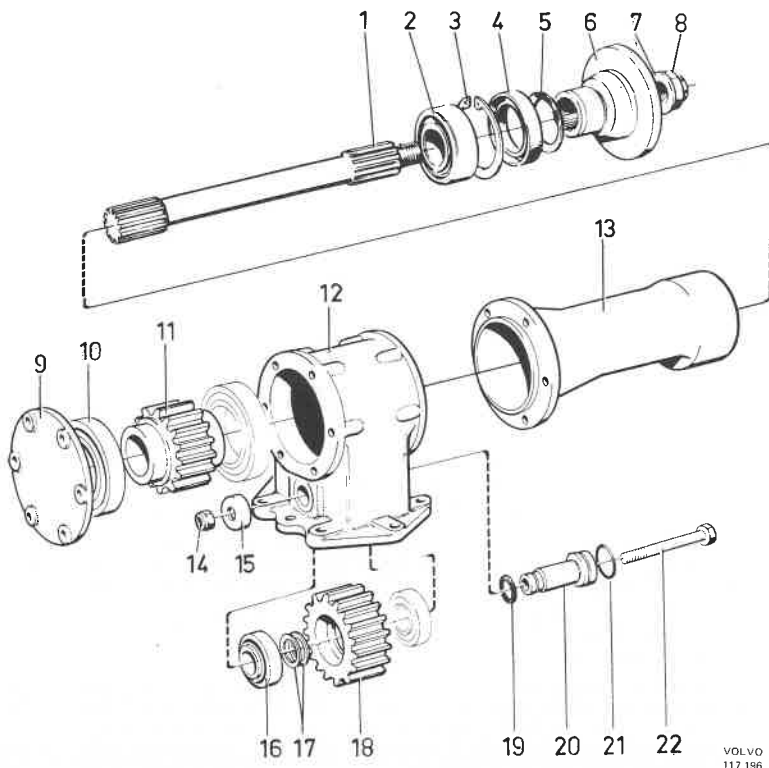


VOLVO  
115 986

**Illustration 46-G. Power take-off**

**Power take-off**

- 1 Drive shaft
- 2 Bearing
- 3 Circlip
- 4 Seal
- 5 Seal
- 6 Flange
- 7 Washer
- 8 Nut
- 9 Cover
- 10 Bearing
- 11 Gear
- 12 Housing
- 13 Housing
- 14 Nut
- 15 Washer
- 16 Bearing
- 17 Chims
- 18 Gear
- 19 D-ring
- 20 Shaft
- 21 O-ring
- 22 Bolt

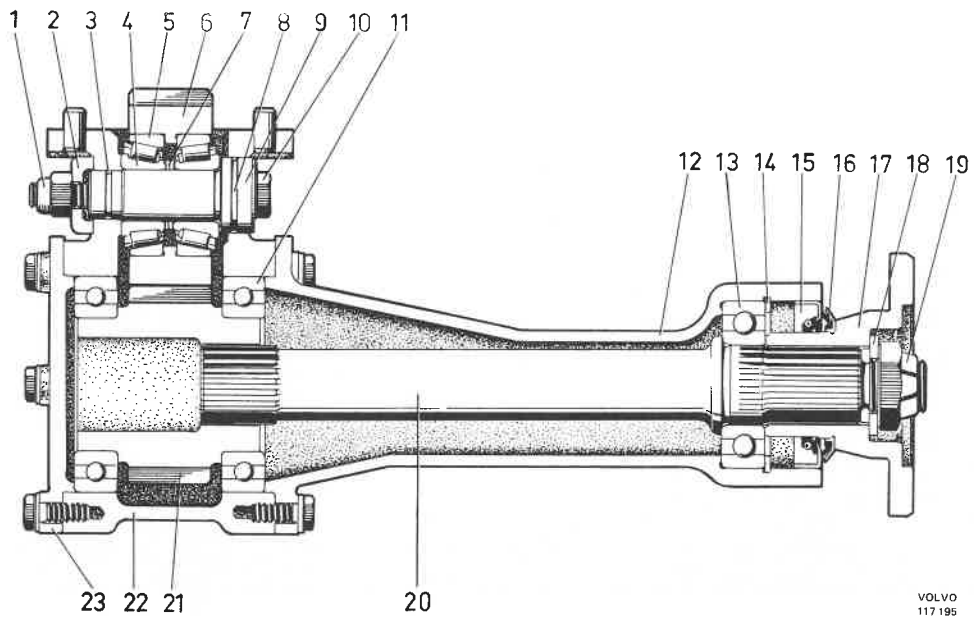


VOLVO  
117 196

**Illustration 46-H. Power take-off**

**Power take-off**

- 1 Nut
- 2 Washer
- 3 O-ring
- 4 Outer ring
- 5 Roller bearing, innerring
- 6 Gear
- 7 Chims
- 8 O-ring
- 9 Washer
- 10 Bolt
- 11 Bearing
- 12 Housing
- 13 Bearing
- 14 Circlip
- 15 Seal
- 16 Seal
- 17 Flange
- 18 Washer
- 19 Nut
- 20 Drive shaft
- 21 Gear
- 22 Housing
- 23 Cover



VOLVO  
117 195

## GROUP 48 POWER TAKE-OFF

### Description

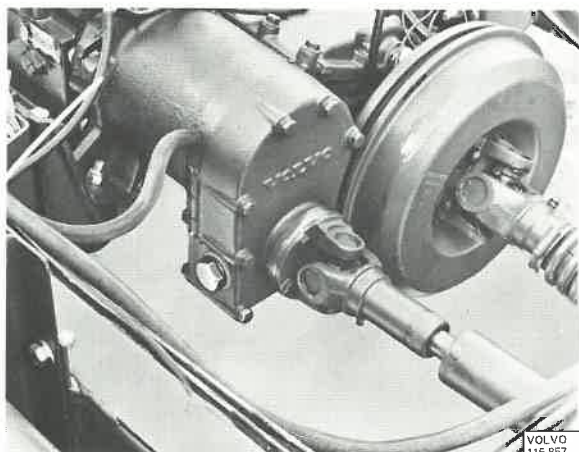


Fig. 48-1. Power take-off

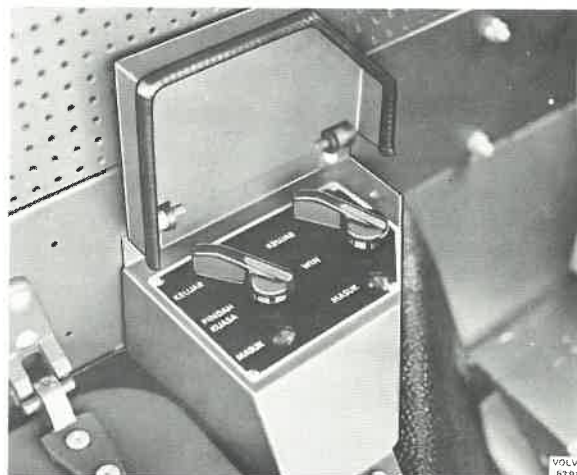


Fig. 48-2. Control for power take-off

### POWER TAKE-OFF

For driving optional equipment, for example, a winch, a power take-off can be connected to the auxiliary gearbox. This type of power take-off is seen in Fig. 48-1.

The construction of the power take-off can be seen from Illustration 48-A. The power take-off housing is of aluminium and consists of two halves. Journalled in the housing is an input and an output shaft. On the

input shaft is a flange, which is meshed with the drive gear of the auxiliary gearbox. The output shaft is driven via a gear on the input and the output shafts which are in constant mesh.

The power take-off is engaged by a control, Fig. 42-2, located at the side of the engine casing, which is connected to the vehicle vacuum system. When the power take-off is engaged, see Fig. 48-3 and 48-4, its bellows are actuated by a vacuum and the flange engages with the auxiliary gearbox drive gear.

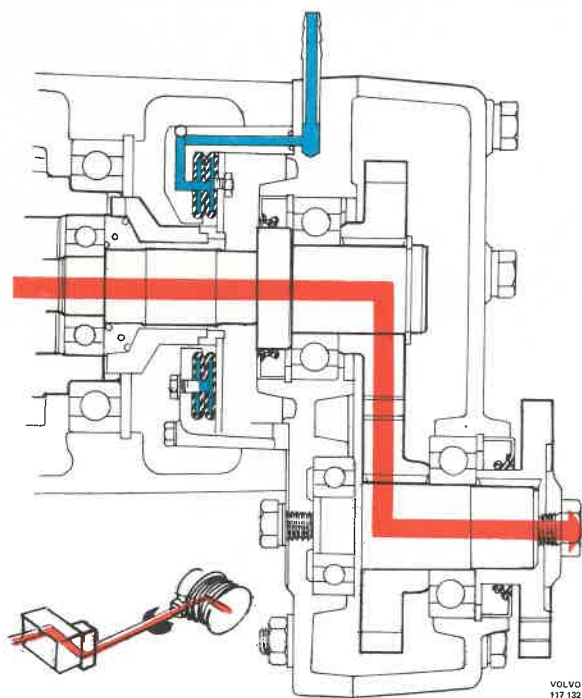


Fig 48-3 Power take-off is engaged

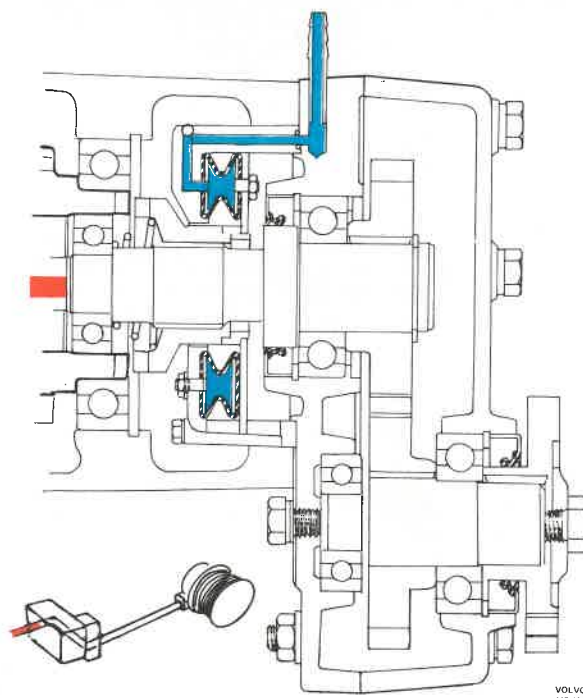


Fig 48-1 Power take-off is disengaged

## Service procedures

Work which can be done in the vehicle

### Replacing the O-ring on the control crank

1. Place a suitable tool under the handle, and pull the handle out of the housing.
2. Replace the O-ring on the handle Fig. 48-5 and coat it with a little grease.
3. Press the handle into the housing. Check to make sure that the differential lock can be engaged and disengaged.

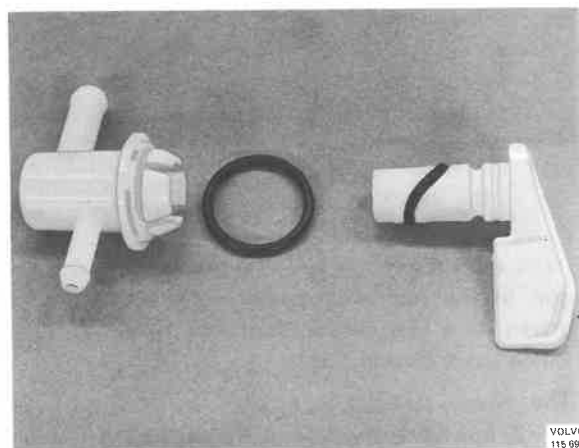


Fig. 48-4. Power take-off controls

### Replacing power takeroff control

1. Place a suitable tool under the knob and pull the knob out of the housing.
2. Remove the four screws securing the plate.
3. Remove the lock ring which holds the control housing to the controls panel.
3. Screw loose the panel see Fig. 48-5. Disconnect the hoses from the housing.
4. Remove the knob from the new control.
5. Place a new O-ring on the housing and fit the housing on the panel. Fit the lock ring.
6. Connect up the hoses. Fit the panel. Screw tight the plate.
7. Press the knob into the housing. Check the function of the power take-off.

48:2

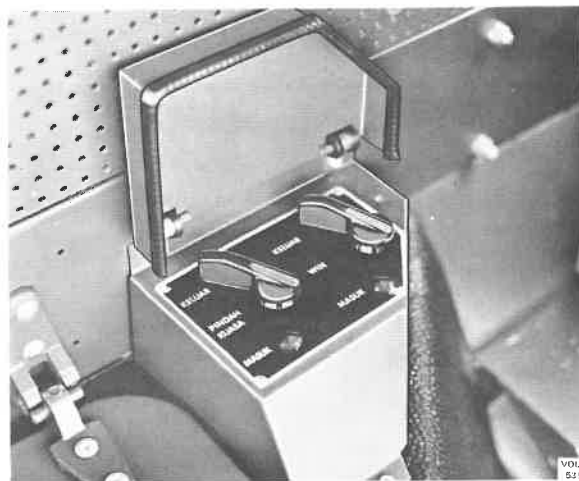


Fig. 48-5. Removing the housing

### Removing of power take-off from auxiliary gearbox

1. Remove the propeller shaft.
2. Drain the oil from the power take-off by removing the screw (2, Fig. 48-6).
3. Remove the bolts securing the cover in the power take-off housing.

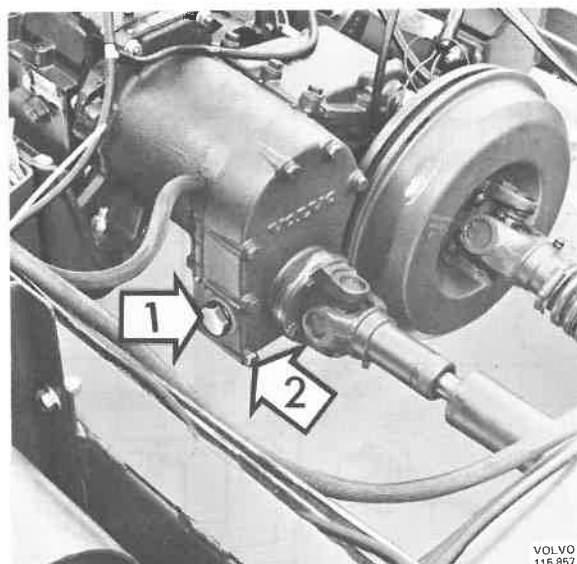


Fig. 48-6. Drain the oil

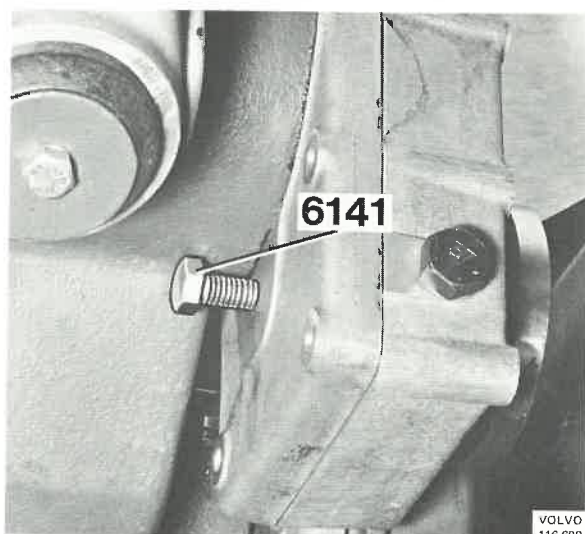


Fig. 48-7. Removing cover

4. Remove the plug, on the power take-off housing. Screw in the separating bolt 6141, Fig. 48-7 and press the cover from the housing. Remove the bolt and push in the plug again.
5. Remove both the inhex bolts, Fig. 48-8, securing the housing to the auxiliary gearbox.

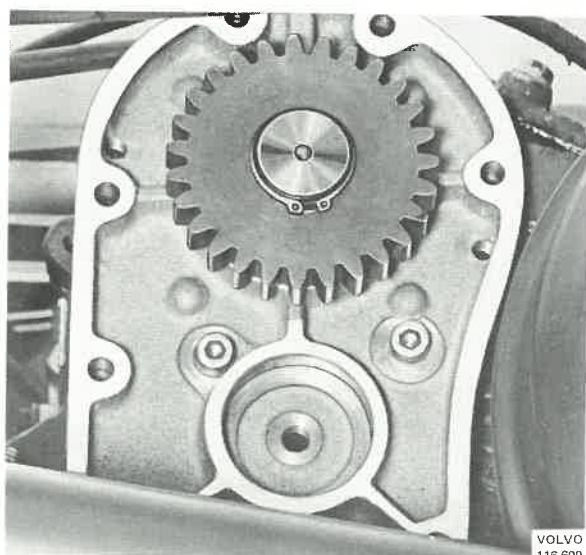


Fig. 48-8. Remove the inner bolts

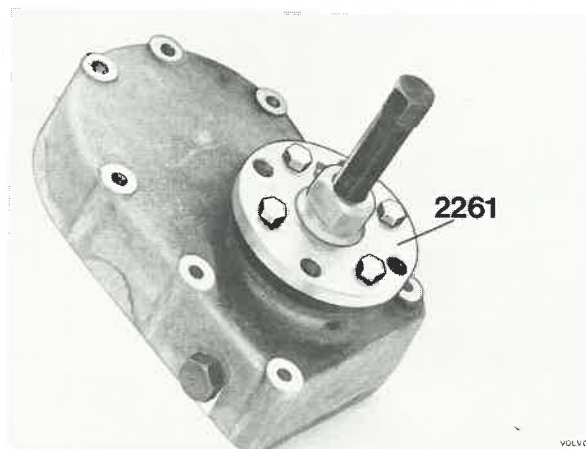


Fig. 48-9. Removing flange

### Disassembling the power take-off

Special tools: 1784, 1801, 2014, 2022, 2261, 2873.

#### Rear housing half

1. Clean the power take-off. Fit counterhold 2873 on the flange and remove the bolt and washer securing the flange.
2. Pull off the flange using 2261, see Fig. 48-9.
3. Press out the output shaft and bearing with 1784, see Fig. 48-10.
4. Remove the key from the shaft.
5. Place the shaft in 2022 and press off the bearing using 1784, see Fig. 48-11.

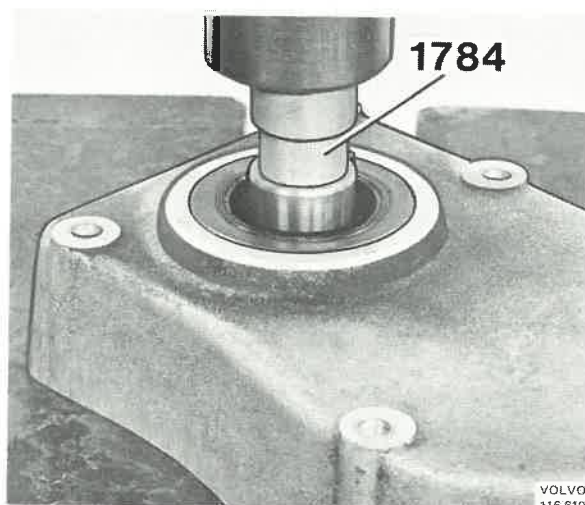


Fig. 48-10. Removing shaft

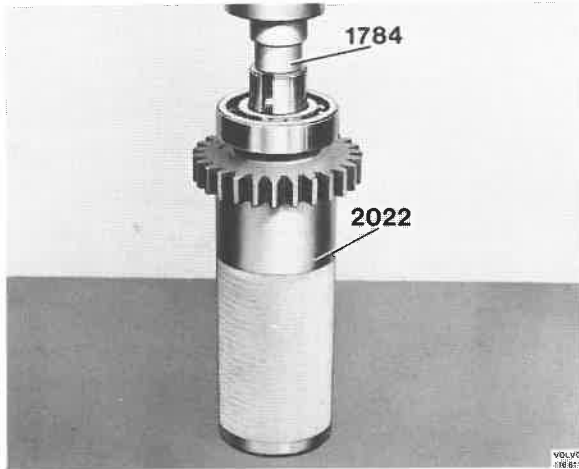


Fig. 48-11. Removing bearing

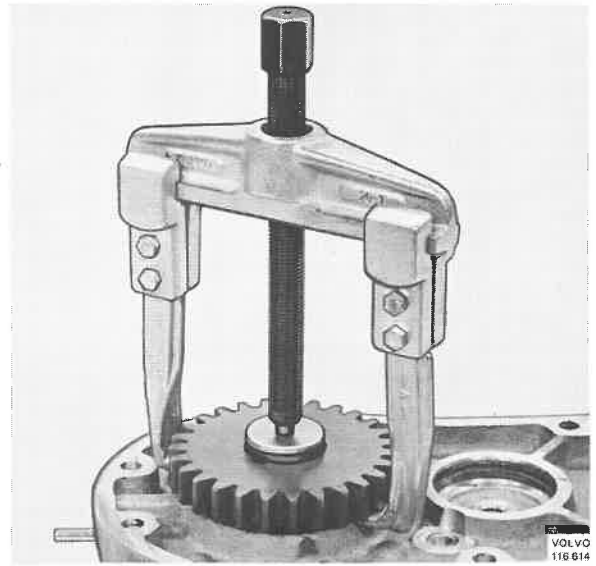


Fig. 48-14. Removing the drive

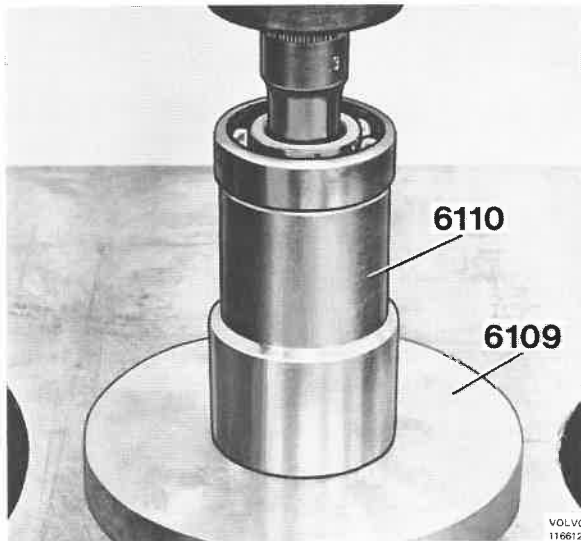


Fig. 48-12. Removing the inner bearing

6. Place the shaft in 6110 and press off the inner bearing, see Fig. 48-12.
7. Remove the circlip in the housing and press out the seal with 1801 + 2014, see Fig. 48-13.

**Front housing half**

1. Remove the circlip on the input shaft and pull off the drive with a standard puller, see Fig. 48-14.

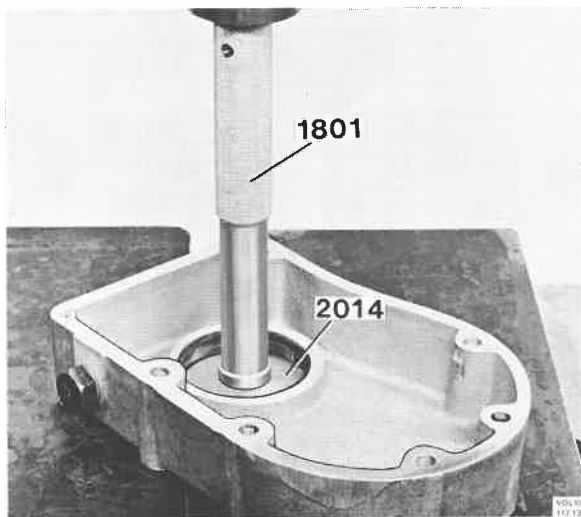


Fig. 48-13. Removing the seal

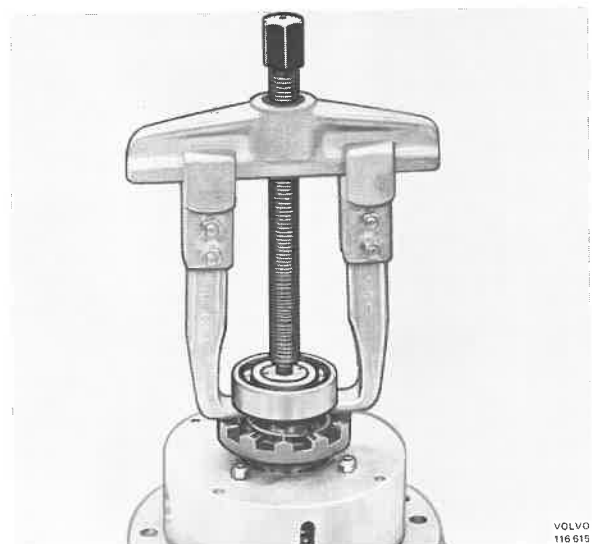


Fig. 48-15. Removing bearing

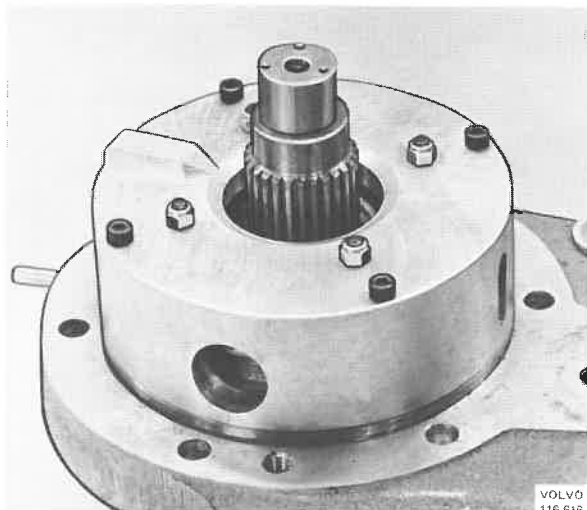


Fig. 48-16. Removing the bolts

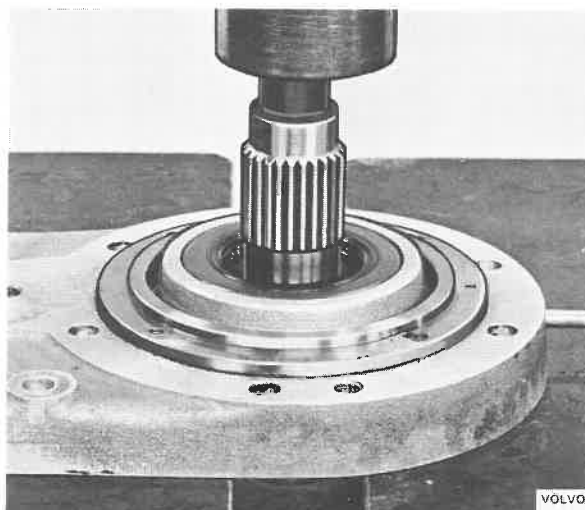


Fig. 48-18. Pressing out the shaft

2. Pull the support bearing off the shaft with a standard puller, see Fig. 48-15. Remove the spring and flange.
3. Remove the retaining bolts (inhex 3 mm = 1/8") holding the control housing, see Fig. 48-16. Remove the housing.
4. Remove the nuts securing the thrust plate, Fig. 48-17, to the bellows.
5. Remove the nuts securing the bellows to the control housing and take out the bellows.
6. Remove the circlip from the input shaft. Press out the shaft and bearing, see Fig. 48-18, from the housing.
7. Remove the key from the shaft.
8. Place the shaft in 2022 and press off the bearing using 1784, see Fig. 48-19.
9. Remove the circlip from the housing and press out the seal with 1801 + 2014.

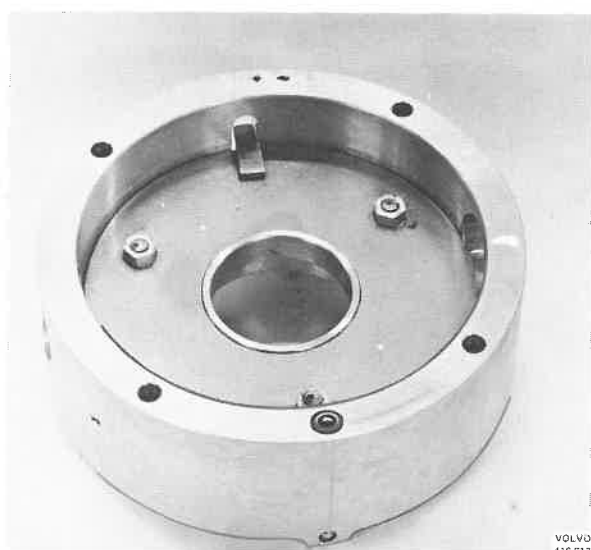


Fig. 48-17. Removing the nuts



Fig. 48-19. Removing the bearing

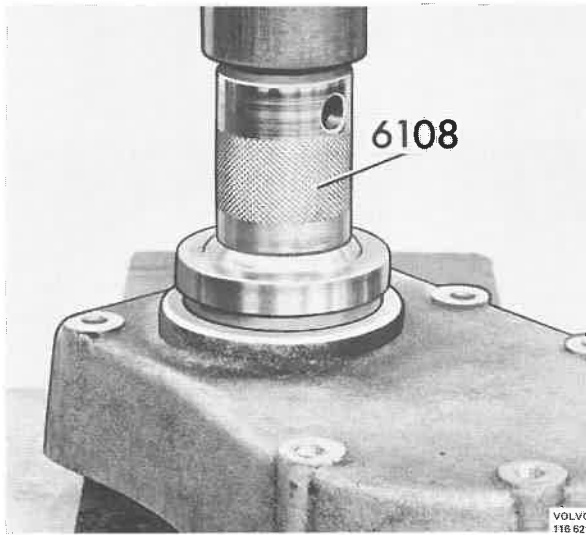


Fig. 48-20. Pressing in the seal

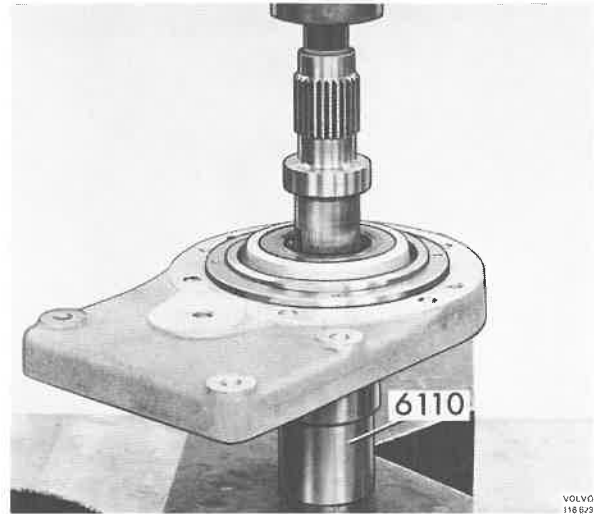


Fig. 48-22. Pressing in the shaft

### Checking and replacing parts

Clean all parts and check them for damage and wear. All damaged or worn parts should be replaced, but sealing rings, O-rings and gaskets must always be replaced. When replacing sealing rings, check carefully the surfaces which have been covered by these rings. If a surface is scored or damaged in any other way, then the particular component with the damaged surface must be replaced.

### Assembling

Special tools: 1801, 2014, 2022, 6108, 6110

#### Assembling the front housing half

1. Place the circlip nearest the sealing in the housing.
2. Place the sealing in the housing with 6108, see Fig. 48-20.
3. Press the bearing into the housing using 1801 + 2014, see Fig. 48-21. Place the circlip which secures the bearing.
4. Place the housing on 6110, see Fig. 48-22, and press in the input shaft.

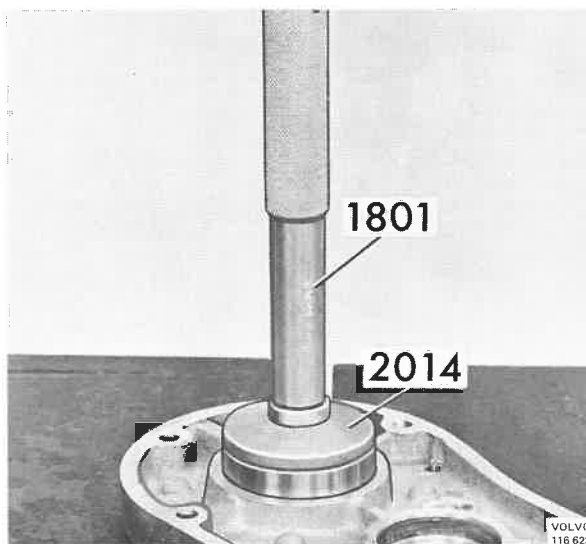


Fig. 48-21. Pressing in the bearing

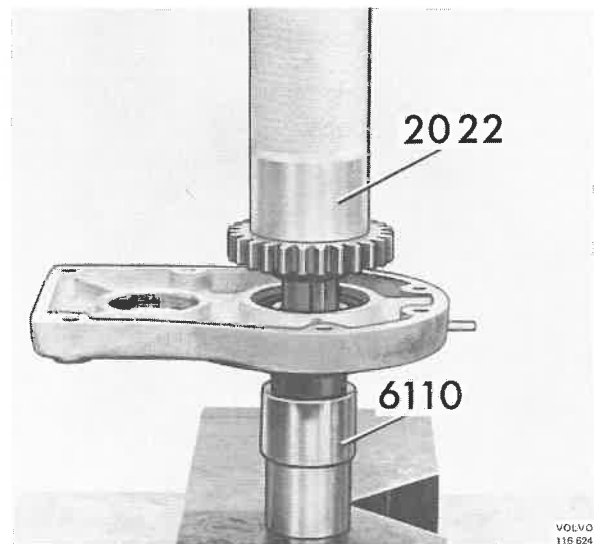


Fig. 48-23. Pressing on the wheel

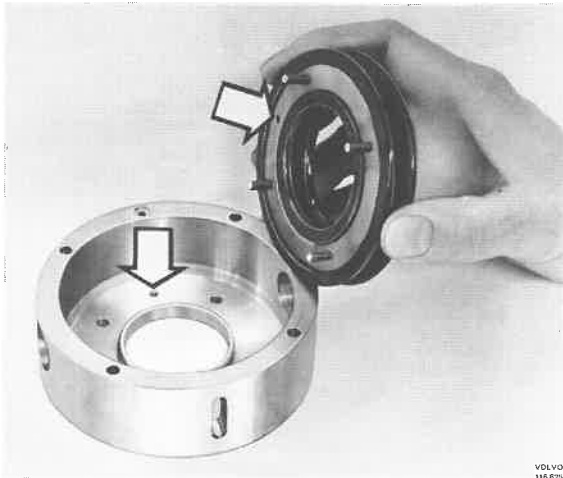


Fig. 48-24. Removing the bellows

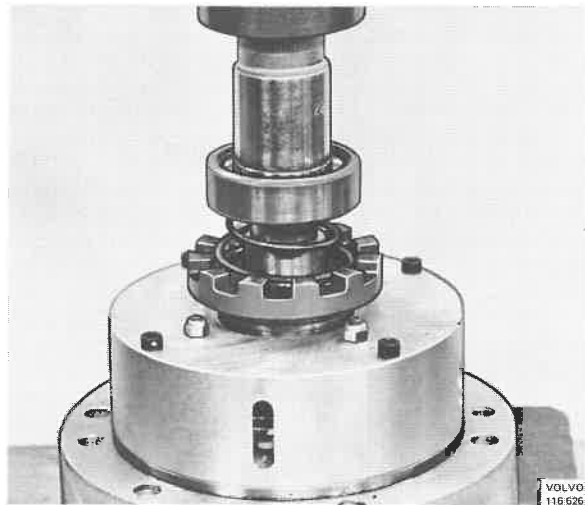


Fig. 48-26. Pressing on the bearing

5. Secure the key for the gear wheel. Place the housing on 6110 and press on the gear wheel with 2022, see Fig. 48-23. Secure the circlip for the gear.
6. Place the bellows on the control housing.  
NOTE! Make sure that the hole in the bellows is opposite the hole in the housing, see Fig. 48-24. Tighten up the bellows.
7. Make sure the bushing is firmly in position by peening it at three points. Place the plate in position and tighten it with the bellows.

8. Place a new O-ring on the control housing, see Fig. 48-25. Assemble the control housing to the housing half. Make sure that the air duct is located properly.
9. Place the flange and the thrust spring on the input shaft, see Fig. 48-26.
10. Press on the support bearing and peen it with three punch pops, see Fig. 48-27.

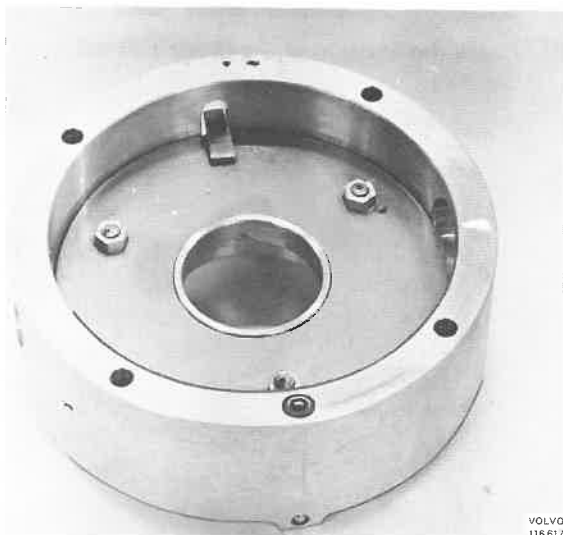


Fig. 48-25. Fitting the O-ring

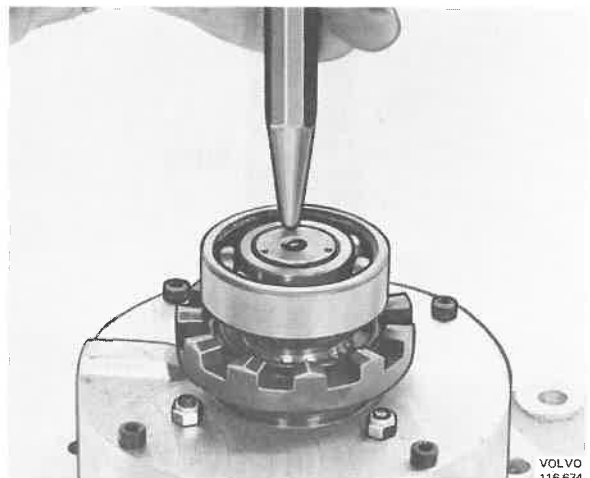


Fig. 48-27. Penning the bearing



Fig. 48-28. Pressing on the wheel

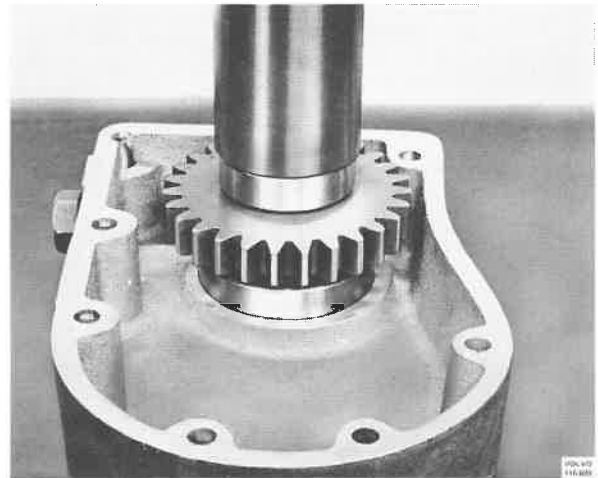


Fig. 48-30. Pressing on the shaft

**Rear housing half**

1. Press the support bearing on the output shaft.
2. Press on the gear wheel with 6110, see Fig. 48-28.
3. Press on the rear bearing with 6110, see Fig. 48-29. Fix the flange key in position.
4. Fit the circlip on the housing half.
5. Press the seal into the housing with 6108. Coat the seal with grease.
6. Press the output shaft into the housing, see Fig. 48-30.
7. Press the flange on the output shaft. Place the washer on the flange and tighten up the bolt to a torque of 41-51 Nm (4.1-5.1 kpm = 30-37 lbftf).

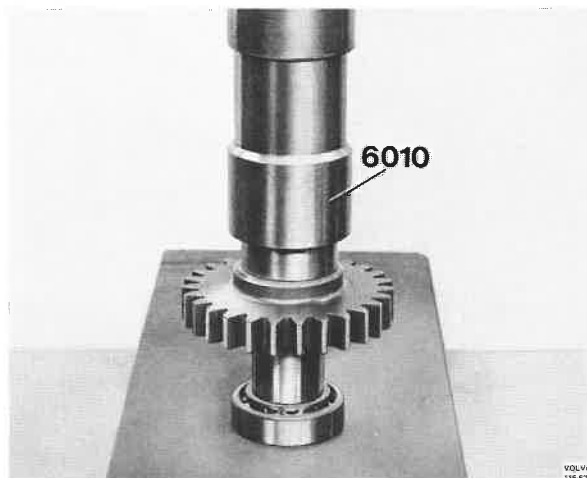


Fig. 48-29. Pressing on the bearing

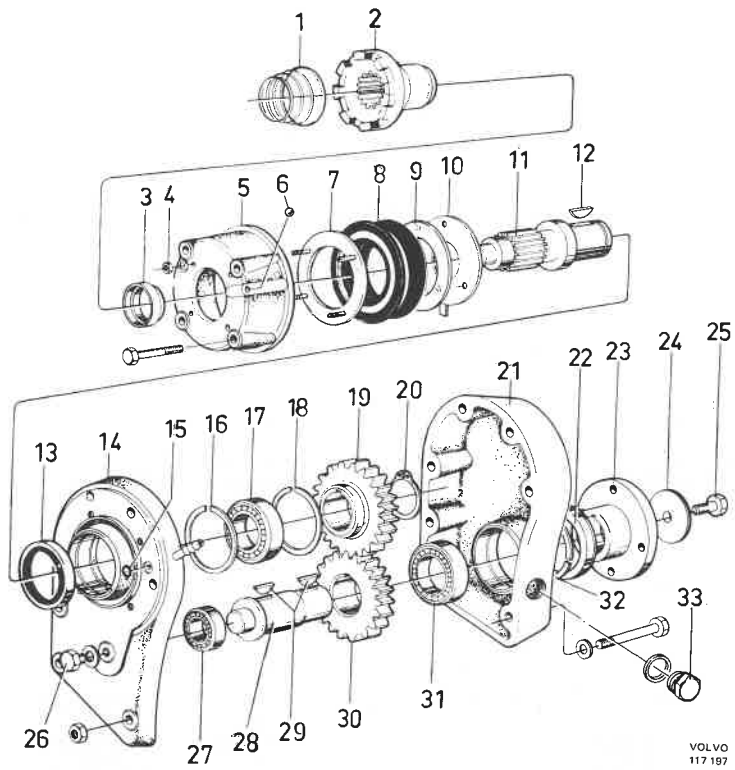
**Installing the power take-off on the auxiliary gearbox**

1. Clean the contact surface on the auxiliary gearbox and coat it with sealing agent.
2. Fit the front housing half on the gearbox. Tighten the bolts to a torque of 20-25 Nm (2.0-2.5 kpm = 14-18 lbftf).
3. Coat the rear housing half contact surface with sealing agent. Mount the housing on the gearbox, turn the flange while putting the housing halves together. Tighten the bolts to a torque of 20-25 Nm (2.0-2.5 kpm = 14-18 lbftf). Fit the ventilation hose.
4. Fit the propeller shaft and tighten the bolts to a torque of 55-65 Nm (5.5-6.5 kpm = 40-47 lbftf).
5. Fill the power take-off with oil. Concerning quantity and quality, see under "Data".
6. Check the function of the power take-off.

**Illustration 48-A. Power take-off**

**Power take-off**

- 1 Spring
- 2 Flange
- 3 Bushing
- 4 Nut
- 5 Conral housing
- 6 Ball
- 7 Attaching plate
- 8 Bellows
- 9 Support plate
- 10 Trust plat
- 11 Input shaft
- 12 Key
- 13 Seal
- 14 Housing
- 15 O-ring
- 16 Circlip
- 17 Bearing
- 18 Circlip
- 19 Drive wheel
- 20 Circlip
- 21 Housing
- 22 Bearing
- 23 Flange
- 24 Washer
- 25 Screw
- 26 Screw
- 27 Bearing
- 28 Output shaft
- 29 Key
- 30 Wheel
- 31 Bearing
- 32 Circlip
- 33 Screw



VOLVO  
117 197

**Illustration 48-B. Power take-off**

**Power take-off**

- 1 Drive gear and auxiliary gearbox
- 2 Bearing
- 3 Spring
- 4 Flange
- 5 Control housing
- 6 Bellows
- 7 Bushing
- 8 Thrust plate
- 9 Seal
- 10 Circlip
- 11 O-ring
- 12 Housing
- 13 Bearing
- 14 Circlip
- 15 Input shaft
- 16 Drive wheel
- 17 Key
- 18 Housing
- 19 Circlip
- 20 Key
- 21 Key
- 22 Screw
- 23 Flange
- 24 Washer
- 25 Seal
- 26 Circlip
- 27 Bearing
- 28 Output shaft
- 29 Wheel
- 30 Bearing
- 31 Screw

